



Your Solutions Partner

Specifications

F.O.B. Sedalia, Missouri 65301



DPAH-3M

OPTIONS:

- False Bottom
- Beaded openings, 12" x 20"
- Tray shelves
- Fluorescent lights
- Incandescent bullet lights
- Adapter bars
- Legs in lieu of casters
- Body latches
- Tray shelf on end

DUKE MANUFACTURING CO.

2305 N. Broadway

St. Louis, MO 63102

800.735.3853 Toll Free

314.231.5074 Fax

www.dukemfg.com

SS-1082 Econo Mate Mechanically Assist Ice

Approval Stamp(s):

PRODUCT INFORMATION:

PROJECT: _____

ITEM: _____

QUANTITY: _____

MODEL:

Econo Mate™ Buffet Units -

Mechanically Assisted Ice Pans

- DPAH-2M Portable 26" liner
- DPAH-3M Portable 40" liner
- DPAH-4M Portable 54" liner

BODY:

- Heavy gauge paint grip steel
- Choice of available powder coat paint colors
- Heavy gauge; 300 Series stainless steel top
- Clear Plexiglas canopy, with black powder coat steel brackets with end enclosures

BASES:

- Closed base with doors
- 5" NSF listed black swivel casters, 2 with locks

COLD PAN COMPARTMENT:

- Fully insulated stainless steel pan
- 5" deep liner with 1" brass drain and plug
- Width of liner 19-7/8

REFRIGERATION:

- Copper oils attached to bottom of s/s liner
- Open angle- iron base in compressor compartment
- R448a refrigerant
- On/Off switch
- Six foot cord with plug - NEMA 5-15
- Five year warranty on compressor motor

Certifications:



UL/ANSI NSF4

Specification subject to change

REV B 04/18/2019

ECONO MATE BUFFET UNITS - COLD UNITS - MECHANICALLY ASSISTED ICE

Catalog No. EMB-MECHCOLD

A.I.A. File No. 35-C-13

Econo-Mate®

Buffet Units - Mechanically Assisted Ice Pans

A.I.A. File No. 35-C-13

Catalog No. EMB-MECHCOLD

ECONO MATE BUFFET UNITS - COLD UNITS - MECHANICALLY ASSISTED ICE

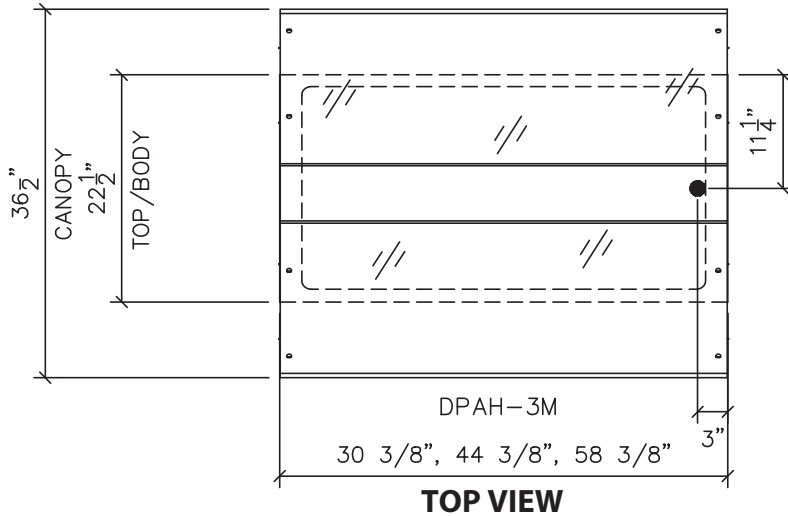

LEGEND	
▲	ELECTRICAL CONNECTION
●	DRAIN LOCATION
R448a Refrigerant	

ELECTRICAL SPECIFICATIONS:

Model	120 Volt		
	HP	Amps	NEMA
DPAH-2M	1/4	5.15	5-15
DPAH-3M	1/4	5.15	5-15
DPAH-4M	1/4	5.15	5-15

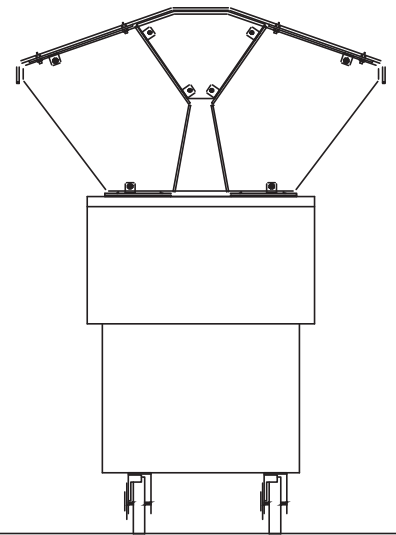
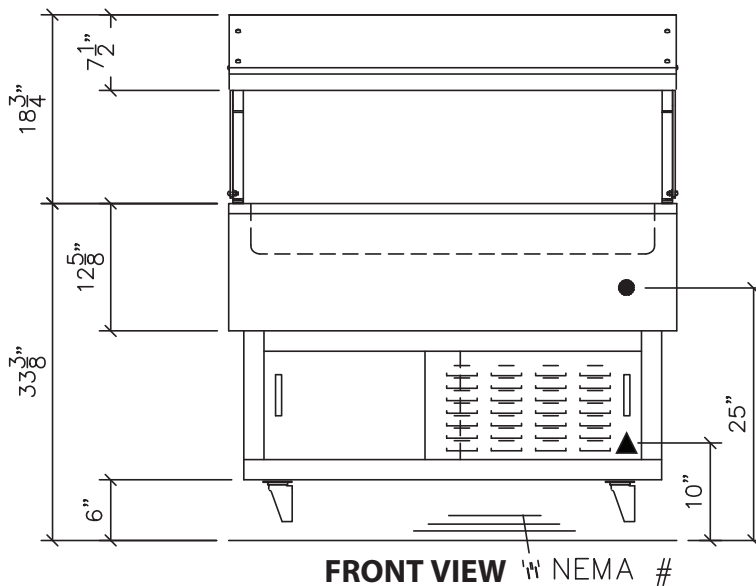

DIMENSIONS:

FREIGHT CLASS: 115

Model	Length		Width		Height		Liner Dimensions in.			Cube ft. Crated	Weight	
	in	cm	in	cm	in	cm	L	W	D		lbs	kg
DPAH-2M	30-3/8	77.2	22-1/2	57.2	33-3/8	84.8	26	19-7/8	5	23.1	244	110.9
DPAH-3M	44-3/8	112.8	22-1/2	57.2	33-3/8	84.8	40	19-7/8	5	32.0	291	132.3
DPAH-4M	58-3/8	148.3	22-1/2	57.2	33-3/8	84.8	54	19-7/8	5	40.9	322	146.4



Duke Manufacturing Co.
2305 N. Broadway
St. Louis, MO 63102

Phone: 314-231-1130
Toll Free: 1-800-735-3853
Fax: 314-231-5074

www.dukemfg.com