



Your Solutions Partner

Specifications

F.O.B. Sedalia, Missouri 65301



TCM-46-N7

OPTIONS:

- Internal Locking device
- 10" deep pan liner
- 14 gauge tops
- 220v - 50 Hz compressor
- Condensate evaporator
- 50 cycle compressor
- False Bottom
- Foodshields
- Workshields
- Trayslides
- Sliding/Hinged doors
- Tray Slides
- 6" adjustable Stainless steel legs
- 8' or 10' cord and plug
- Food pans - see Top Equipment section in price guide
- Veneered plastic laminate panels on body
- Powder coat paint colors
- Drain and condensing unit on operator's left
- Kickplates SS & PG

AGENCY LISTINGS:



DUKE MANUFACTURING CO.

2305 N. Broadway

St. Louis, MO 63102

800.735.3853 Toll Free

314.231.5074 Fax

www.dukemfg.com

SS-1053 Thurmaduke SS Cold Mech N7

Approval Stamp(s):

PRODUCT INFORMATION:

PROJECT: _____

ITEM: _____

QUANTITY: _____

MODEL:

Thurmaduke™ Serving Systems - Cold Pan

Mechanically Cooled - Meets NSF Standard 7 - 8"

Deep

- **TCM-32-N7** 32" length unit
- **TCM-46-N7** 46" length unit
- **TCM-60-N7** 60" length unit
- **TCM-74-N7** 74" length unit
- **TCM-88-N7** 88" length unit

TOP:

- 16 gauge, 300 Series stainless steel
- Edges flanged down 2" at 90° - all four sides
- Inside edges flanged down 90° against liner

COLD PAN LINER:

- 300 Series stainless steel - 5" deep
- Insulated on all four sides and bottom
- 1" drain pipe and shut-off valve on operator's right

REFRIGERATION:

- 120 VOLT - 1 Phase - R134A refrigerant
- Condensing unit below top on operator's right
- Stainless steel louvered grille for air circulation
- Copper coils attached to bottom of 8" liner
- 6' electric cord and plug - NEMA 5-15
- Necessary controls for operation

BODY:

- Choice of (12) powder coat paint colors contact sales
- Stainless steel body
- Operator's side open to bottom shelf
- Customer side and ends fully enclosed
- Bottom shelf paint grip or stainless steel to match body

Specification subject to change



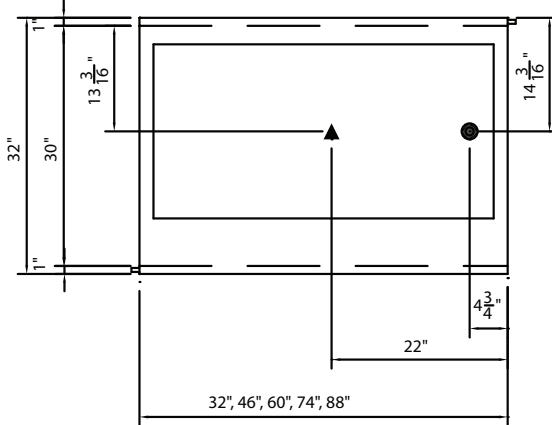

TOP VIEW

LEGEND	
▲	ELECTRICAL CONNECTION - 6' Cord & Plug
●	DRAIN LOCATION - 1" brass drain, shut-off valve, drain extension 7" above floor

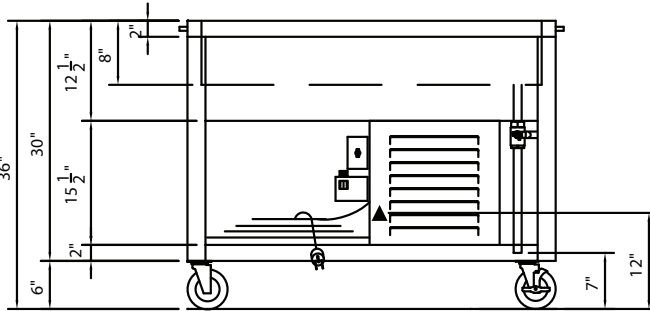

FRONT VIEW

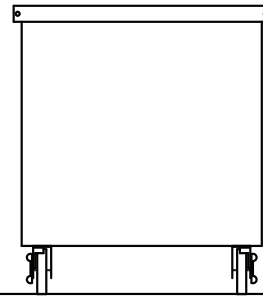

RIGHT SIDE VIEW

DIMENSIONS: Mechanical 8" Deep Cold Pan - All Units: Height - 36" (91.4 cm); Width - 32: (81.3cm)

FREIGHT CLASS: 150

Model	Body Length		Cold Pan Liner Dimensions						Cube ft. crated	Weight	
			Length		Width		Depth			lbs	kg
	in	cm	in	cm	in	cm	in	cm			
TCM-32-N7	32	81.3	28 1/2	72.4	21 3/4	55.3	8	20.3	34.8	255	115.9
TCM-46-N7	46	116.8	42 1/2	108.0	21 3/4	55.3	8	20.3	47.7	354	160.9
TCM-60-N7	60	152.4	56 1/2	143.5	21 3/4	55.3	8	20.3	60.5	425	193.2
TCM-74-N7	74	188.0	70 1/2	179.1	21 3/4	55.3	8	20.3	73.3	518	235.5
TCM-88-N7	88	223.5	84 1/2	214.6	21 3/4	55.3	8	20.3	86.2	580	263.4

ELECTRICAL SPECIFICATIONS: (Consult factory for other options)

Model	120 Volt/NEMA 5-15	
	Amps	HP
TCM-32-N7	2.8	1/5
TCM-46-N7	4.4	1/4
TCM-60-N7	4.4	1/4
TCM-74-N7	4.8	1/3
TCM-88-N7	4.8	1/3



Duke Manufacturing Co.
2305 N. Broadway
St. Louis, MO 63102

Phone: 314-231-1130
Toll Free: 1-800-735-3853
Fax: 314-231-5074

www.dukemfg.com