



a Standex company

ITEM: _____ PROJECT NAME: _____ DATE: _____

COUNTER TOP SIGNATURE SERIES NON-REFRIGERATED

**MODEL CD3628
CD4828**



The Signature Series counter top merchandiser combines attractive curved glass styling and merchandising flexibility. Designed for continuous case line-ups. Cases are available in lengths of 3' and 4'.

STANDARD FEATURES

- Curved glass styling.
- Adjustable black wire shelves. Shelves are adjustable up and down and can also be tilted in two positions. Two tiers.
- Tempered front and end glass.
- Shielded top light and shelf lights.
- Removable sliding rear doors, shelf lights, shelf supports, and shelves.
- Scratch-resistant black display deck.
- Easily accessible light switch.
- Black painted metal and stainless construction. Black trim.
- Designed for continuous line-ups.
- Cord and plug (NEMA 5-15P).
- UL Safety and UL Sanitation Listed.

SIGNATURE SERIES NON-REFRIGERATED COUNTER TOP MERCHANDISER

OPTIONAL ACCESSORIES:

- 9" See EZ View
- DVM [hV] Ve
- DVM [hV] Sd6 aade
- BWS I [fZI dbb] Y4aScV
- /Fa? sUZ DVM Y4aScV
- ? ag fG [ffi
- LED Lighting

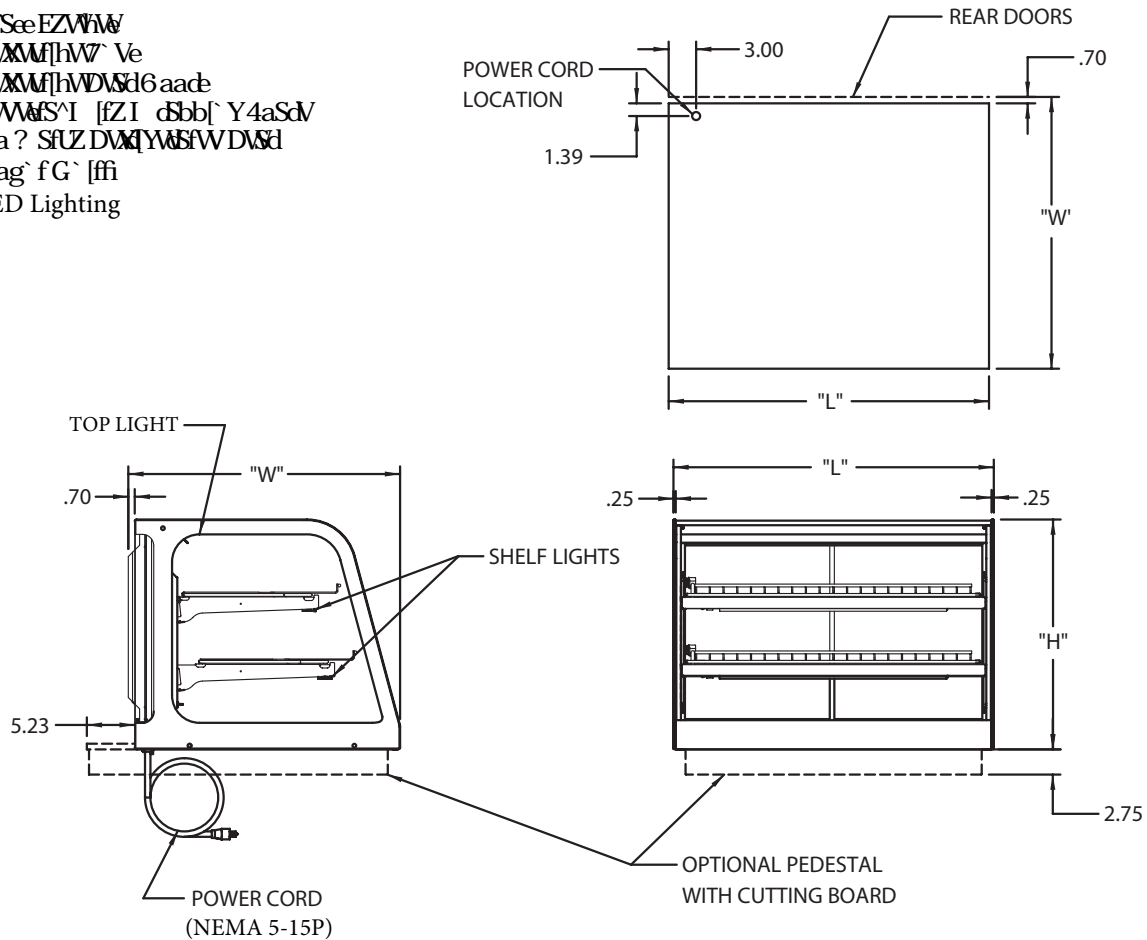

SPECIFICATIONS:

Model	Dimensions			Shipping Weight (lbs)	Electrical 120/60/1
	L	W	H		
CD3628	35"	29.7"	25.12"	280	1.5 AMPS
CD4828	47"	29.7"	25.12"	320	1.5 AMPS

- If a GFCI circuit is required, a GFCI Breaker Must be used instead of GFCI receptacle.
- Due to continuing engineering improvements, specifications are subject to change without notice.



Look to Federal for Innovative Merchandising



The Signature of Quality

FEDERAL INDUSTRIES
A Standex Company

215 FEDERAL AVENUE, BELLEVILLE, WISCONSIN 53508-9201

PHONE: 800-356-4206

EMAIL: geninfo@federalind.com

FAX: 608-424-3234

WEBSITE: www.federalind.com

