



COMBI CK-48V

2 in 1: high capacity vegetable cutter (1,300 lbs./h) + cutter with 8 liter bowl



DYNAMIC PREPARATION
FOOD PROCESSOR / VEG PREP COMBI MACHINES



FEATURES AND BENEFITS

As a cutter, its head with the blade on one side distributes products inside the mouth and cuts and distributes whole products such as cabbage. Supplied with a central drill, optional use, with the same purpose. The head is equipped with a top ejector, which enables more product to be shifted and the indicated production levels achieved. As a food processor, it has a 8-lt bowl with mixer and micro-serrated blades.

Equipped with "brushless" technology: powerful and efficient motors.

- ✓ Maximum efficiency: maintain the torque throughout the speed range.
- ✓ Exclusive "force control system": guarantee of a uniform and high quality result.
- ✓ Lightweight and compact design: they weigh less, they occupy less space.
- ✓ Improved air/water-tightness since no ventilation is required.
- ✓ They generate less noise: improved workplace environment.

Cutting function: a perfect cut

- ✓ High precision settings and comprehensive cutter and disc design aimed at obtaining a perfect cut.
- ✓ It can be fitted with a wide range of discs and grids of the highest cutting quality. Combining these accessories together to obtain more than 70 different types of cuts and grating grades.
- ✓ Exclusive "Force Control System" to optimise and standardise the cutting of each product: acoustic warning when the motor exceeds the pre-established force.

Cutter function: efficiency and performance

- ✓ Possibility of programming by time and pulse button.
- ✓ Reverse function, ideal for mixing products instead of cutting.
- ✓ 8 litre stainless steel bowl.
- ✓ Polycarbonate lid with built-in "cut&mix" mixer.
- ✓ Depending on the purpose, the possibility of using optional smooth or perforated blades.

Built to last

- ✓ Made from stainless steel and food-grade materials of the highest quality: stainless steel motor block and food-grade aluminium head. Stainless steel bowl with highly-resistant polycarbonate lid.

Maximum comfort for the user

- ✓ Ergonomic design. Maximum comfort for the user.
- ✓ Lateral product output: it requires less room on the work surface and directs the product avoiding splashing.
- ✓ Advanced control panel that is very intuitive to use and offers all the information at a glance.

Maintenance, safety, hygiene

- ✓ Plunger, lid and hopper easy to remove for changing or cleaning.
- ✓ Combination of security systems: head, covers, bowl, power switch.
- ✓ Appliance certified by NSF International (regulations on hygiene, cleaning and materials suitable for contact with foods).
- ✓ 100% tested.

INCLUDES

- ✓ Variable speed motor block.
- ✓ Large capacity head.
- ✓ Cutter bowl, with micro-serrated blade rotor.

ACCESSORIES

- FCC Curved Slicing Discs
- FCO Rippled Slicing Discs
- FFC Chipping Grids
- FMC Dicing Grids
- FCE Julienne Discs
- FR Shredding & Grating Discs
- Disc and Grid Packs
- Disc and Grid Holder
- Blades for CK / K / KE
- Grid Cleaning Kit
- FC-D Slicing Discs
- SH Shredding & Grating Discs :: NEW: Detachable without tools & dishwasher safe

SALES DESCRIPTION

It has a variable speed motor block, large-capacity head and 8-lt cutter bowl equipped with a rotor with micro-serrated blades.

Brushless technology.



sammic | www.sammic.us
Food Service Equipment Manufacturer

usa@sammic.com phone +1 (224) 307-2232
 1225 Hartrey Avenue toll free +1 844 275 3848
 60202-1056 Evanston, IL



Project	Date
Item	Qty
Approved	

product sheet updated 01/10/20



COMBI CK-48V

2 in 1: high capacity vegetable cutter (1,300 lbs./h) + cutter with 8 liter bowl



SPECIFICATIONS

Total loading: 3 Hp

As vegetable preparation machine

Hourly production: 400 lbs. - 1300 lbs.

Inlet opening: 44.4 in2

Disc diameter: 8 "

Speed as veg. slicer: 300 rpm - 1000 rpm

External dimensions (WxDxH): 15.4 " x 15.7 " x 25.7 "

Net weight: 67.9 lbs.

As cutter

Bowl capacity: 8.5 qt.

Speeds as cutter (positions): 300 rpm - 3000 rpm

External dimensions (WxDxH): 11.3 " x 15.2 " x 20.4 "

Net weight (Cutter): 41.9 lbs.

Noise level (1m.): <70 dB(A)

Background noise: 32 dB(A)

Crated dimensions

27.8 x 16.3 x 20.3 "

Volume Packed: 0.15 m³

Gross weight: 79.6 lbs.

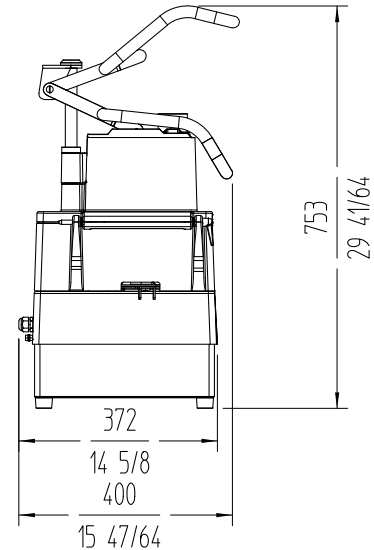
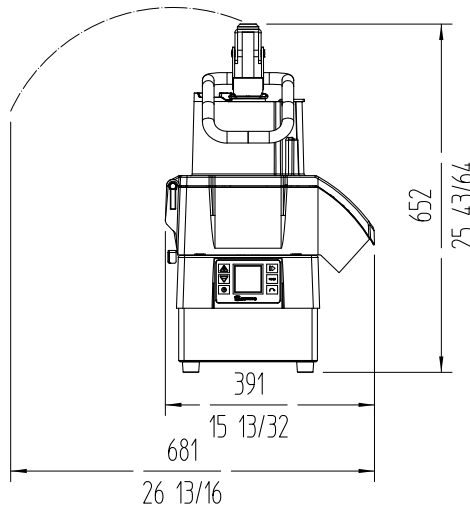
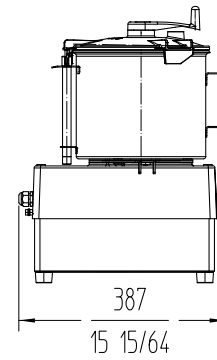
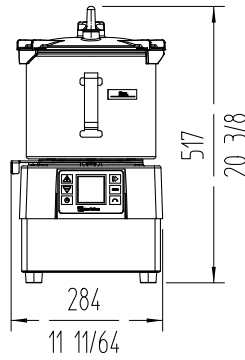

DYNAMIC PREPARATION
FOOD PROCESSOR / VEG PREP COMBI MACHINES

AVAILABLE MODELS

1050822 Combi vegetable prep.-cutter CK-48V 120/50-60/1

* Ask for special versions availability

sammic | www.sammic.us
Food Service Equipment Manufacturer

usa@sammic.com phone +1 (224) 307-2232
1225 Hartrey Avenue toll free +1 844 275 3848
60202-1056 Evanston, IL



Project	Date
Item	Qty
Approved	

product sheet
updated 01/10/20