



VACUUM PACKING MACHINE SU-420P+ 120/50-60/1 (WITH PLUS WELDING OPTION)

Tabletop model. 20 m³/h. 420 mm.



Cód. 1140785

FEATURES AND BENEFITS

- ✓ Powered by Busch.
- ✓ Vacuum controlled by sensor.
- ✓ Vacuum PLUS.
- ✓ LCD colour screen: all information at a glance.
- ✓ Backlit touch keyboard.
- ✓ Programmable: 25-programme memory. Blocking option.
- ✓ "Pause" button.
- ✓ Phased vacuum programme.
- ✓ Detection of the evaporation of liquids.
- ✓ Double seal.
- ✓ Cordless sealing bar.
- ✓ Progressive decompression.
- ✓ Vac-Norm ready with Automatic decompression.
- ✓ Stainless steel body and chamber. Deep-drawn chamber.
- ✓ Damped transparent lid of high durability polycarbonate.
- ✓ Dry-oil programme for drying the pump.
- ✓ Working hours counter for oil changes.
- ✓ Safety system with protection against vacuum failure.

INCLUDES

- ✓ Filling plate
- ✓ Printer connection
- ✓ Bluetooth connectivity
- ✓ "Plus" sealing system



SALES DESCRIPTION

- 420 mm. sealing bar.
- 20 m³/h Busch vacuum pump.
- Vacuum controlled by sensor.



sammic | www.sammic.us
Food Service Equipment Manufacturer

usa@sammic.com
1225 Hartrey Avenue
60202-1056 Evanston, IL

phone +1 (224) 307-2232
toll free +1 844 275 3848



Project	Date
Item	Qty
Approved	

FOOD PRESERVATION AND SOUS-VIDE
VACUUM PACKING MACHINES - "SENSOR ULTRA" LINE

product sheet
updated 19/04/2018



VACUUM PACKING MACHINE SU-420P+ 120/50-60/1 (WITH PLUS WELDING OPTION)

Tabletop model. 20 m³/h. 420 mm.



Cód. 1140785

SPECIFICATIONS

- Pump capacity: 700 cf/h
- Bar length: 16.5 "
- Total loading: 1 Hp
- Vacuum pressure (maximum): 2 mbar
- Electrical supply: 120 V / 60 Hz / 1 ~ (13 A)

Internal dimensions

- ✓ Width: 17 "
- ✓ Depth: 16 "
- ✓ Height: 7 "

External dimensions (WxDxH)

- ✓ Width: 19 "
- ✓ Depth: 20.8 "
- ✓ Height: 17.6 "

Net weight: 154 lbs.

Noise level (1m.): 75 dB(A)

Background noise: 32 dB(A)

Crated dimensions

600 x 600 x 620 mm

Gross weight: 65 Kg.

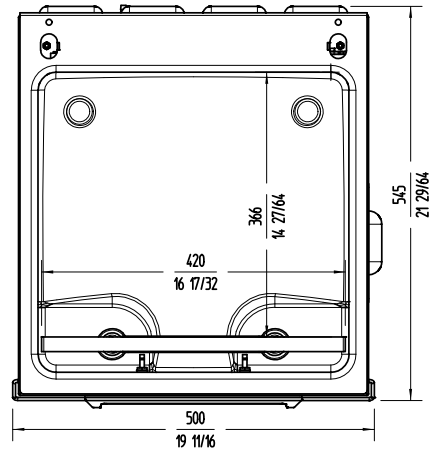
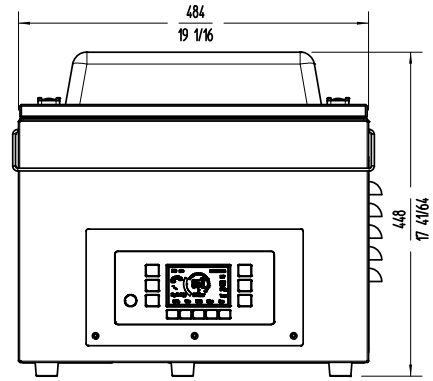
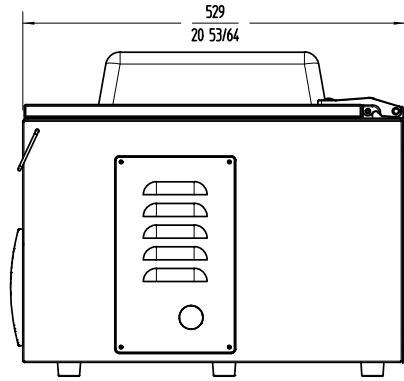

ACCESSORIES

- Bag cutting kits
- Filling plates
- Liquid insert plates
- Vac-norm external vacuum kits
- Vac-norm containers
- Smooth bags for vacuum packing
- Trolley for vacuum packing machines
- CG2 Desktop printer for SU vacuum packing machines *
- Thermal labels for CG2 printer

FOOD PRESERVATION AND SOUS-VIDE
VACUUM PACKING MACHINES - "SENSOR ULTRA" LINE

sammic | www.sammic.us
Food Service Equipment Manufacturer

usa@sammic.com
1225 Hartrey Avenue
60202-1056 Evanston, IL

phone +1 (224) 307-2232
toll free +1 844 275 3848



Project

Date

Item

Qty

Approved

product sheet
updated 19/04/2018