



### Commercial Gas Stock Pot

Model	Burners
IRSP-1B	One 3-ring burner
IRSP-2B	Two 3-ring burners



### STANDARD FEATURES

#### Construction

- Stainless steel front, back and sides
- 8" adjustable non skid stainless steel legs
- Removable, easy to clean crumb tray
- 3/4" rear NPT gas connection

#### Stock Pot Features

- Heavy 1-7/8" thick removable cast iron top grate
- Cool to touch front provides comfortable work zone
- High performance burners giving off 80,000 total BTU output (Natural Gas); 50,000 total BTU (LPG)

#### Control

- 3-ring cast iron burners
- Dual control valves
- LPG conversion kit included
- Warranty: 1 year parts and labor

### SPECIFICATIONS

With 80,000 BTU high heat per burner for the natural gas and 50,000 BTU high heat per burner for the LPG gas, the Iron Range Stock Pot is designed to withstand the most demanding of commercial environments. The one and two burner stock pots allow you to prepare pot after pot of soups and sauces without taking up too much floor space.

The stainless steel construction combined with the heavy-duty cast iron top grate and burners provides long-lasting durability while the removable crumb tray and lift-off burners make it easy to clean. 3-ring cast iron burners and dual control valves assure efficiency and even cooking temperature.

Units are shipped for natural gas but are easily converted to LPG (propane) gas with the LPG conversion kit that is included.

All Commercial Gas Stock Pots carry ETL approval for gas and sanitation that pass USA requirements for use in food service.





### Important Information:

- A convertible pressure regulator is provided with this unit.  
 Natural Gas 4.0" (102 mm) W.C.  
 Propane Gas 10.0" (279 mm) W.C.
- Gas connection is 3/4" NPT (19mm) rear gas connection

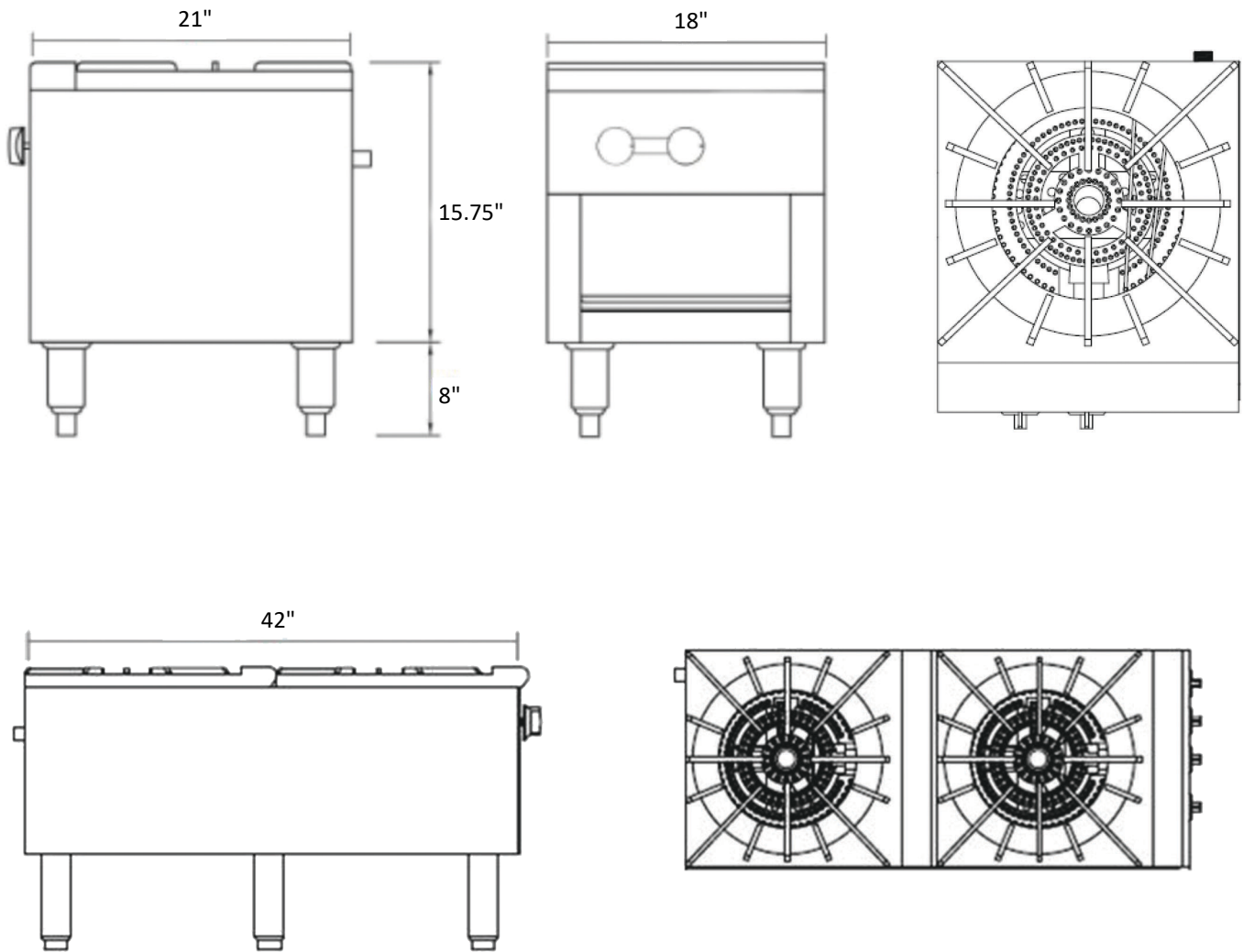

Model	Burners	External Dimensions			Total BTU's		Crated Weight (lbs)
		W	D	H	Natural	LP	
IRSP-1B	One 3-ring burner	18	21	24	80,000	50,000	145
IRSP-2B	Two 3-ring burners	18	42	24	160,000	100,000	292

Specifications are subject to change without notice.

