



## MAKE THE STEEL RITE !

Toll Free:855-855-0399 Email:info@atosausa.com  
www.atosa.com | www.atosausa.com  
California,Colorado,Florida,Georgia, Illinois,Massachusetts,New Jersey,Ohio,Texas,  
Washington

# Stainless Steel Equipment Stands

### Standard Features

- ◆ This stand ships unassembled to save you on shipping cost. Tools are included for easy assembly.
- ◆ Its sturdy, stainless steel top surface and undershelf are designed to withstand constant use in your busy commercial Kitchen.
- ◆ The adjustable undershelf and bullet feet provide additional storage space, as well as optimum stability.
- ◆ Safety hemmed edge around the sides and back comes standard to keep equipment and other contents from sliding off.
- ◆ Added H-shape reinforced rib underneath the top surface makes it able to support more evenly distributed weight.



ATSE-2824



ATSE-2836



ATSE-2848



### Specifications

Model	L(IN)	W(IN)	H(IN)	PACKAGE SIZE (IN)	NET WEIGHT(LBS)	GROSS WEIGHT(LBS)
ATSE-2824	24	28	24	25*29*7	39.7	44
ATSE-2836	36	28	24	37*29*7	53	57.3
ATSE-2848	48	28	24	49*29*7	64	71.6

## Plan View

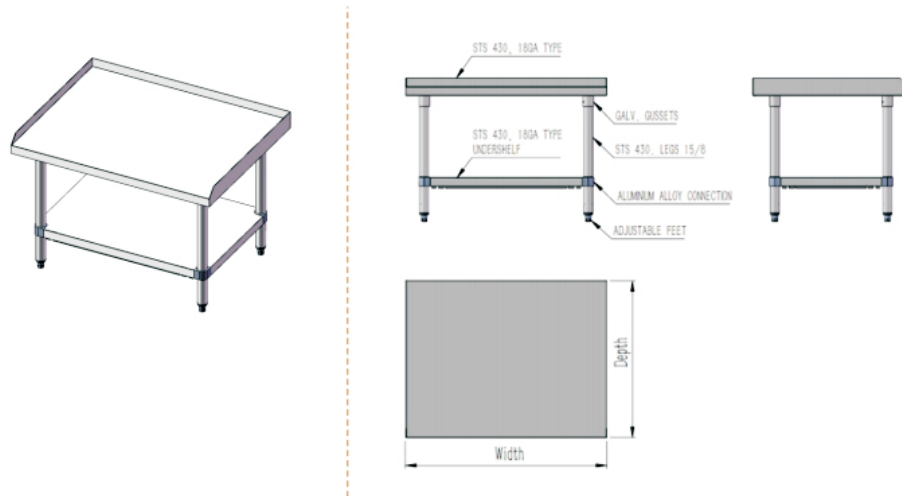

## Terms and Conditions

### One Year Limited Warranty

Atosa Catering Equipment warrants its equipment against defects in materials and workmanship, subject to the following conditions: Atosa Catering Equipment is warranted for one year, effective from the date of purchase by the original owner. A copy of the original receipt or other proof of purchase is required to obtain warranty coverage. This warranty applies to the original owner only, and is nontransferable. Should any product fail to function in its intended manner under normal use within the limits defined in this warranty, at Atosa's discretion, such product will be replaced with a new unit by Atosa, after defective unit has been inspected. And defect has been confirmed. Atosa does not assume any liability for extended delays in replacing any item beyond its control. This warranty does not apply to plastic and non-metallic synthetic parts that may need to be replaced due to normal usage, or lack of preventative maintenance.

### WHAT IS NOT COVERED BY THIS WARRANTY

- Equipment that has not properly been maintained, damage from improper cleaning, and water damage to controls.
- Equipment that has not been used in an appropriate manner, or has been subject to misuse, neglect, abuse, accident, alteration, negligence, damage during transit, fire, flood, or acts of God.

If the equipment has been changed, altered, modified, or repaired without express written permission from Atosa, then the manufacturer shall not be liable for any damages to any person or to any property, which may result from the use of this equipment thereafter.

For warranty and non-warranty related issues, technical support, purchase replacement parts contact Atosa toll free (855) 855-0399

\*In some cases, a 25% restocking fee may be charged to a buyer for returned items.