



Your Solutions Partner

Specifications

F.O.B Sedalia, Missouri 65301



ASI-3G

OPTIONS:

- Safety pilots
- Thermostats
- Designer Foodshields
- Telescope covers
- Hardwood carving board
- S/S carving surface
- S/S dish shelf
- S/S spillage pan
- Removable S/S carving station
- Adapter Plates
- Drop-in style top rim

AGENCY LISTING:



DUKE MANUFACTURING CO.
 2305 N. Broadway
 St. Louis, MO 63102

800.735.3853 Toll Free
314.231.5074 Fax
www.dukemfg.com

Approval Stamp(s):

PRODUCT INFORMATION:

PROJECT: _____

ITEM: _____

QUANTITY: _____

MODEL:

Slide-Ins

Hot Food - Gas

- ASI-1G** 18-1/4"L x 23-7/16"W x 15-3/4"H
- ASI-2G** 32-1/4"L x 23-7/16"W x 15-3/4"H
- ASI-3G** 46-1/4"L x 23-7/16"W x 15-3/4"H
- ASI-4G** 60-1/4"L x 23-7/16"W x 15-3/4"H
- ASI-5G** 74-1/4"L x 23-7/16"W x 15-3/4"H
- ASI-6G** 88-1/4"L x 23-7/16"W x 15-3/4"H

TOP RIM:

- Heavy gauge, 300 Series stainless steel
- Die-stamped openings - 12-1/16" x 20-1/16"
- 15/16" overhang on back and ends
- Reinforced with heavy gauge steel angle
- Vinyl foam gasket as sealant
- Operator's side turn down

HEAT COMPARTMENTS:

- Die-formed 8" deep stainless steel liners - dry operation
- 1" fiberglass insulation, all four sides and bottom
- Individual burners under each well - 3500 BTU/HR input each
- Adjustable gas valve & pilot light for each burner
- Galvanized steel radiation plate each compartment
- Gas pressure regulator included
- Include 576 aluminum spillage pans

EXTERIOR HOUSING

- Heavy gauge paint grip steel on one side and both ends
- Stainless steel on operator's side

SHORT FORM SPECIFICATIONS:

Duke Slide-Ins - Hot Food - Gas. Top flange of heavy gauge 300 series s/s with overhang on back and ends and operator side turned down, 12-1/16" x 20-1/16" die-stamped hot food openings, each opening with burner for natural or propane, rated at 3500 BTU, with gas valve, regulator, adjustable pilot light, 8" deep s/s liner fully insulated, s/s top, interior liner, operator's rail and control panel, steel exterior, s/s operator's side

Duke®

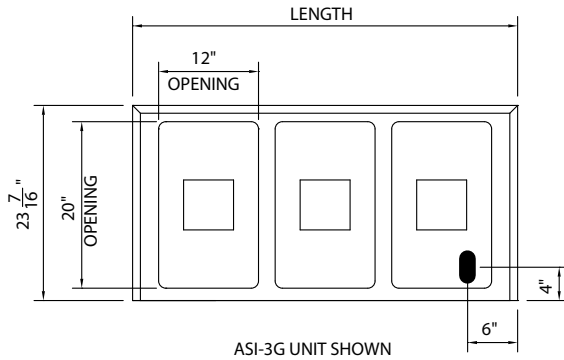

TOP VIEW

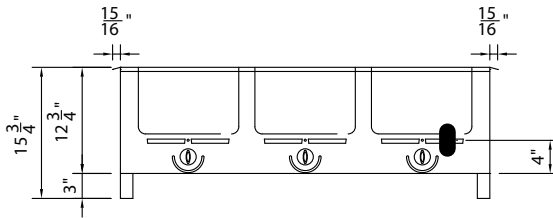

FRONT VIEW

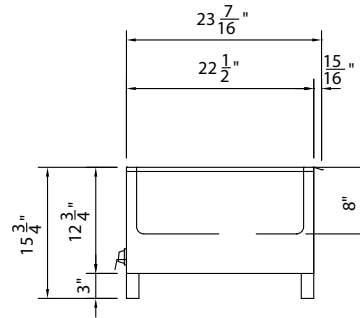

RIGHT SIDE VIEW

SLIDE-INS HOT FOOD - GAS

- ASI-1G** 18-1/4"L x 23-7/16"W x 15-3/4"H
- ASI-2G** 32-1/4"L x 23-7/16"W x 15-3/4"H
- ASI-3G** 46-1/4"L x 23-7/16"W x 15-3/4"H
- ASI-4G** 60-1/4"L x 23-7/16"W x 15-3/4"H
- ASI-5G** 74-1/4"L x 23-7/16"W x 15-3/4"H
- ASI-6G** 88-1/4"L x 23-7/16"W x 15-3/4"H

LEGEND	
■	- GAS CONNECTION

DIMENSIONS:

FREIGHT CLASS: 100

Model	Length		Width		Height		Top Openings	Cutout Length		Cutout Width		Cube ft. Crated	Weight	
	in.	cm	in.	cm	in.	cm		in.	cm	in.	cm		lbs.	kg.
ASI-1G	18-1/4	46.4	23-7/16	59.7	15-3/4	32.4	1	17	43.2	23	58.4	9.1	43	19.6
ASI-2G	32-1/4	81.9	23-7/16	59.7	15-3/4	32.4	2	31	78.7	23	58.4	14.5	130	59.1
ASI-3G	46-1/4	117.5	23-7/16	59.7	15-3/4	32.4	3	45	114.3	23	58.4	19.6	170	77.3
ASI-4G	60-1/4	153.0	23-7/16	59.7	15-3/4	32.4	4	59	149.9	23	58.4	25.1	210	95.5
ASI-5G	74-1/4	188.6	23-7/16	59.7	15-3/4	32.4	5	73	185.4	23	58.4	30.3	240	109.1
ASI-6G	88-1/4	224.2	23-7/16	59.7	15-3/4	32.4	6	87	221.0	23	58.4	35.6	290	131.8

Power Supply:

1/2" IPS threaded pipe gas connection from supplied gas pressure regulator
Specify natural gas or propane gas when ordering
For high altitude orifice, specify elevation when ordering

NOTES:

No combustible materials should be stored under unit
Allow proper air flow beneath unit to insure gas burns cleanly

DUKE MANUFACTURING CO.

2305 N. Broadway
St. Louis, MO 63102

800.735.3853 Toll Free
800.231.1130 In Missouri
314.231.5074 Fax
www.dukemfg.com



Specification subject to change