



Your Solutions Partner

Specifications

F.O.B Sedalia, Missouri 65301



HB2HF

OPTIONS:

- Three phase wiring - not available with 120v
- Internal locking device
- Foodshields
- Trayslides
- 1-color laminate on body/second color laminate on trayslide
- Laminate finish other than standard eight (8) finishes
- Lights in canopy
- Height/lights in canopy
- Kickplates s/s or p/g
- Bread and cheese board
- End Shelf
- Legs in lieu of casters

AGENCY LISTING:



DUKE MANUFACTURING CO.
2305 N. Broadway
St. Louis, MO 63102

800.735.3853 Toll Free
314.231.5074 Fax
www.dukemfg.com

SS-1014 Heritage Hot Food-Electric

Approval Stamp(s):

PRODUCT INFORMATION:

PROJECT: _____
 ITEM: _____
 QUANTITY: _____

MODEL:

Heritage® Buffet - Hot Food - Electric

- HB2HF** 32" length unit w/(2) heat wells
- HB3HF** 46" length unit w/(3) heat wells
- HB4HF** 60" length unit w/(4) heat wells
- HB5HF** 74" length unit w/(5) heat wells

TOP:

- 16 gauge, 300 Series stainless steel
- Flanged down 2" on all four (4) sides
- Die-stamped beaded openings - 12" x 20"

BODY:

- Heavy gauge paint grip steel
- Laminate patterns: Available upon request
- Stainless steel trim strips on corners
- Flanged and channeled edges for strength
- Welded together with reinforcements
- Removable access panel on one end
- Mounted on NSF listed 5" diameter swivel casters, two with locks, all non-marking polyurethane tires

HOT FOOD SECTION

- Stainless steel sealed wells 12" x 20", insulated with fiberglass
- Each section to have electric elements under well
- Individual brass drains, copper manifolds and brass master valve
- Individual infinite controls
- 6' cord and plug

HERITAGE®

Heritage® Buffet - Hot Food - Electric

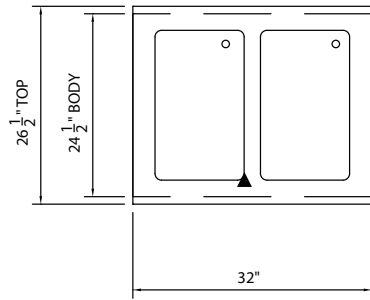

TOP VIEW

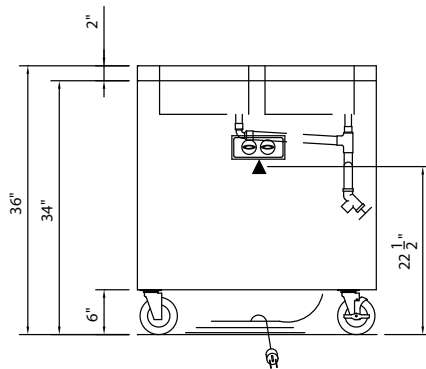

FRONT VIEW

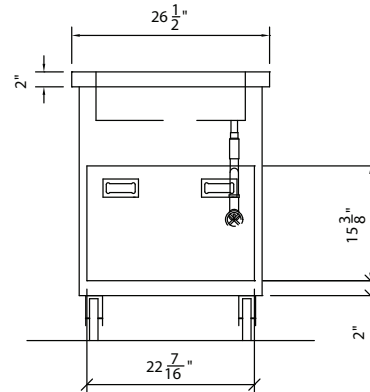

RIGHT SIDE VIEW

DIMENSIONS:

FREIGHT CLASS: 100

Model	Length		Width		Height		Cube ft. crated	Weight	
	in.	cm.	in.	cm.	in.	cm.		lbs	kg
HB2HF	32	81.3	26-1/2	67.3	36	91.4	26.3	265	120.5
HB3HF	46	116.8	26-1/2	67.3	36	91.4	36.0	395	180.0
HB4HF	60	152.4	26-1/2	67.3	36	91.4	45.7	525	238.6
HB5HF	74	188.0	26-1/2	67.31	36	91.4	55.4	655	297.7

ELECTRICAL SPECIFICATIONS:

Model	120 Volt - 750 watt elements			208 Volt - 750 watt elements			240 Volt - 750 watt elements		
	watts	amps	NEMA	watts	amps	NEMA	watts	amps	NEMA
HB2HF	1500	12.5	5-15	1500	7.2	6-20	1500	6.3	6-20
HB3HF	2250	18.8	L5-30	2250	10.8	6-20	2250	9.4	6-20
HB4HF	3000	25.0	5-50	3000	14.4	6-20	3000	12.5	6-20
HB5HF	3750	31.3	5-50	3750	18.0	L6-30	3750	15.6	6-20



DUKE MANUFACTURING CO.

2305 N. Broadway
St. Louis, MO 63102

800.735.3853 Toll Free
314.231.1130 In Missouri
314.231.5074 Fax
www.dukemfg.com

Specification subject to change

Printed in U.S.A
© 2018, Duke Manufacturing Co.