



VACUUM PACKING MACHINE SU-810GP+ 208-240/60/3

Floorstanding unit. 100m³/h. 530+848 mm.



P/N. 1140973



FEATURES AND BENEFITS

- ✓ Powered by Busch.
- ✓ Vacuum controlled by sensor.
- ✓ Vacuum PLUS.
- ✓ LCD colour screen: all information at a glance.
- ✓ Backlit touch keyboard.
- ✓ Programmable: 25-programme memory. Blocking option.
- ✓ "Pause" button.
- ✓ Phased vacuum programme.
- ✓ Detection of the evaporation of liquids.
- ✓ Double seal.
- ✓ Cordless sealing bar.
- ✓ Progressive decompression.
- ✓ Vac-Norm ready with Automatic decompression.
- ✓ Stainless steel body and chamber.
- ✓ Damped transparent lid of high durability polycarbonate.
- ✓ Dry-oil programme for drying the pump.
- ✓ Working hours counter for oil changes.
- ✓ Safety system with protection against vacuum failure.
- ✓ NSF-listed.



SALES DESCRIPTION

Two sealing bars (530+848 mm.)
 100 m³/h Busch vacuum pump.
 Vacuum controlled by sensor.

INCLUDES

- ✓ Filling plate.
- ✓ Bluetooth connectivity and connection for printer.

ACCESSORIES

- Bag cutting kits
- Filling plates
- Liquid insert plates
- Vac-norm external vacuum kits
- Vac-norm containers
- Smooth bags for vacuum packing
- Thermal labels for CG2 / RB printer
- RB Desktop printer for SU vacuum packing machines *
- Thermal transfer labels for RB printer



sammic | www.sammic.us
 Food Service Equipment Manufacturer

usa@sammic.com phone +1 (224) 307-2232
 1225 Hartrey Avenue toll free +1 844 275 3848
 60202-1056 Evanston, IL



| | |
|----------|------|
| Project | Date |
| Item | Qty |
| Approved | |

FOOD PRESERVATION AND SOUS-VIDE
 VACUUM PACKING MACHINES - "SENSOR ULTRA" LINE

product sheet
 updated 04/30/20



VACUUM PACKING MACHINE SU-810GP+ 208-240/60/3

Floorstanding unit. 100m³/h. 530+848 mm.



SPECIFICATIONS

Pump capacity: 3500 cf/h
 Bar length: 20.9 "
 Total loading: 3 Hp
 Vacuum pressure (maximum): 0.5 mbar
 Electrical supply: 208 V - 240 V / 60 Hz / 3 ~
 (v:intensidad)

Internal dimensions

- ✓ Width: 34 "
- ✓ Depth: 23.7 "
- ✓ Height: 8.4 "

External dimensions (WxDxH)

- ✓ Width: 37.7 "
- ✓ Depth: 29.8 "
- ✓ Height: 39.2 "

Net weight: 551 lbs.
 Noise level (1m.): 75 dB(A)
 Background noise: 32 dB(A)

Crated dimensions

33.1 x 41.7 x 47.2 "
 Gross weight: 606.3 lbs.

P/N. 1140973

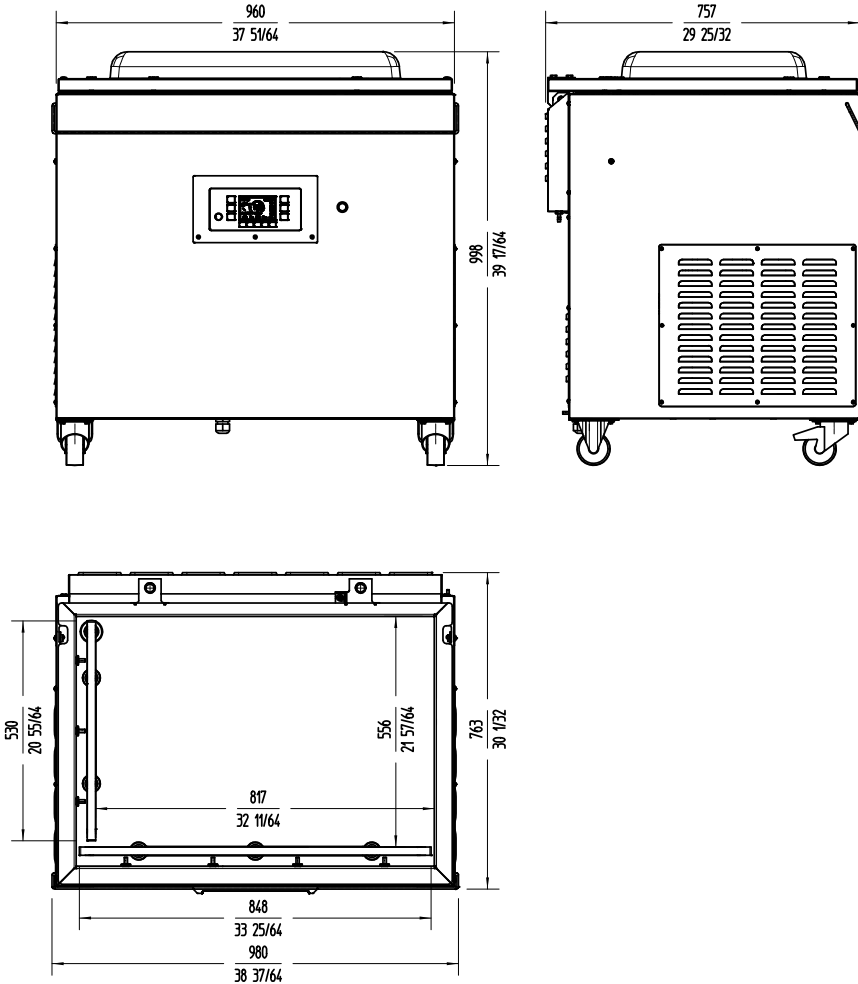

FOOD PRESERVATION AND SOUS-VIDE
 VACUUM PACKING MACHINES - "SENSOR ULTRA" LINE

sammic | www.sammic.us
 Food Service Equipment Manufacturer

usa@sammic.com phone +1 (224) 307-2232
 1225 Hartrey Avenue toll free +1 844 275 3848
 60202-1056 Evanston, IL



| | |
|----------|------|
| Project | Date |
| Item | Qty |
| Approved | |

product sheet
 updated 04/30/20