



# CONVECTION OVEN

## SL-SERIES

GAS, SINGLE DECK

### Standard Features

- Patented, high efficiency, non-clog Inshot burners
- 72,000 BTU (NAT or LP)
- Available standard and bakery depths
- Single deck convection oven is 57-1/2" in height (with optional casters)
- Patented "plug-in, plug-out" control panel - easy to service
- Slide out control panel for full view servicing
- Stainless Steel front, top and sides
- Dependent glass doors (Full 180° opening)
- Energy saving high efficiency glass windows
- Heat keeping dual door seal system
- Coved, fastener-free, porcelain interior
- Stay cool heavy duty door handle
- Soft Air, two speed, 1/2 hp, fan motor
- 11-position rack guides and 5 plated oven racks
- Two speed, 1/2 hp, fan motor
- Electronic ignition with solid state temperature controls
- Forced cool down fan mode
- Oven "heat" light cycles with burners
- Interior oven lights.
- (2) year limited parts and labor warranty (reference <http://www.southbendnc.com/service.html> for limited warranty details)

SLGS/12SC, SLGS/12CCH  
SLGB/12SC, SLGB/12CCH

**OPTIONAL NRG System required for rebates. NRG System units are Energy Star Approved. (Standard Depth Only)**



(SLGS/12SC shown with optional casters)

### Available Controls

#### SC-Standard Controls

140°F to 500°F solid state thermostat and 60 minute mechanical cook timer.

#### CCH-Cycle / Cook & Hold Control

150°F to 550°F temperature controller with 140°F to 200°F "Hold" thermostat dual digital display shows time and temperature. A fan cycle timer pulses the fan.

### STANDARD CONSTRUCTION SPECIFICATIONS

**Exterior Finish:** Stainless steel front, top and sides.

**Doors:** Dependent doors with windows. Low emission glass, stainless steel construction, heavy-duty welded steel frame and 5/8" diameter full-length hinge pin.

**Oven Interior:** Porcelain enamel finish, coved, fastener free. Single oven interior light.

**Rack and Rack Guides:** Heavy-duty removable wire rack guides spaced on 1-5/8" centers offer 11 different rack positions. 5 wire racks provided with each oven.

**Blower Fan and Motor:** 1/2hp, 2-speed motor, 1710/1120 r.p.m

**Oven Heating:** 72,000 BTU (NAT or LP). Oven heating is regulated by an adjustable solid state thermostat control. Blower fan circulates air within the cavity "scrubbing" heat to the oven interior for even heat distribution within the cavity.

**Electronic Ignition:** Hot surface ignitor with flame safety device.

**Control Panel:** Located on front, at right side of oven, away from heat zone. Slide out panel extends over 17" for easy servicing.

**Interior Lights:** Two 40 watt high temperature recessed lamps located within the oven cavity.

**Legs:** 26" Stainless steel, triangular legs standard.



Job #

Models:  SLGS/12SC  SLGS/12CCH  SLGB/12SC  SLGB/12CCH

Dimensions -in (mm)

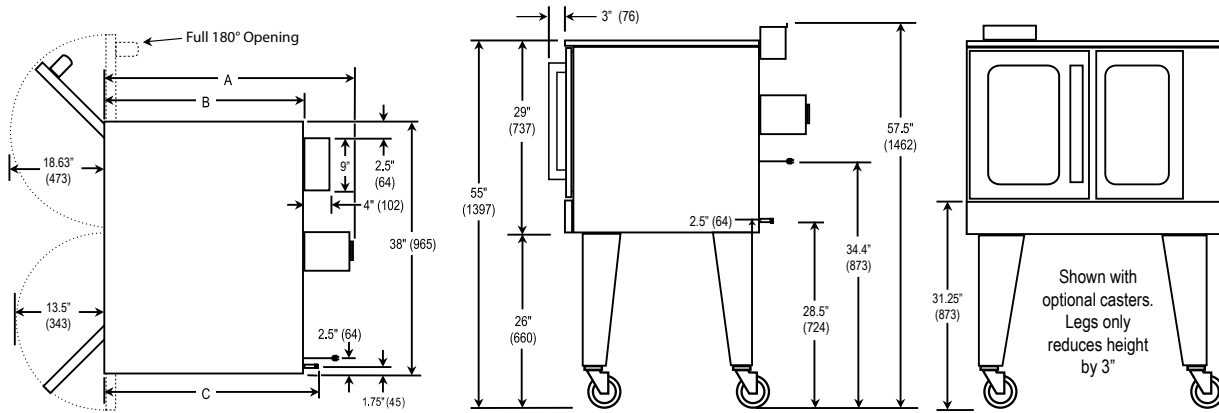

| MODEL   | DEPTH            |                 |                  | OVEN INTERIOR |                 |              | RACK CLEARANCE  |                 | SHIPPING CRATE   |                  |               |                               |                       |
|---------|------------------|-----------------|------------------|---------------|-----------------|--------------|-----------------|-----------------|------------------|------------------|---------------|-------------------------------|-----------------------|
|         | A                | B               | C                | WIDTH         | DEPTH           | HEIGHT       | WIDTH           | DEPTH           | WIDTH            | DEPTH            | HEIGHT        | VOLUME                        | WEIGHT                |
| SLGS/12 | 37.25"<br>(946)  | 30.25"<br>(768) | 33.75"<br>(857)  | 29"<br>(737)  | 21.50"<br>(546) | 20"<br>(508) | 28.25"<br>(718) | 21"<br>(533)    | 57.50"<br>(1461) | 45.50"<br>(1156) | 45"<br>(1143) | 68.1 cu. ft.<br>(1.93 cu. m.) | 600 lbs<br>(272.2kg.) |
| SLGB/12 | 43.50"<br>(1143) | 36.50"<br>(927) | 39.75"<br>(1010) | 29"<br>(737)  | 29"<br>(737)    | 20"<br>(508) | 28.25"<br>(718) | 27.25"<br>(692) | 57.50"<br>(1461) | 45.5"<br>(1156)  | 45"<br>(1143) | 68.1 cu. ft.<br>(1.93 cu. m.) | 650 lbs<br>(294.8kg.) |

**Note:** When shipped on legs, crated height is 69" (1753 mm)

**UTILITY INFORMATION**

- GAS:**
- Standard and Bakery Depth: 72,000 BTU (NAT or LP)
  - One 3/4" male connection
  - Required minimum inlet pressure:
    - Natural gas 7" W.C.
    - Propane gas 11" W.C.

**ELECTRIC:** Standard: 120/60/1 phase, furnished with 6' cord w/3-prong plug (1 plug/deck). NEMA #5-15p. Total maximum amps 7.9.

Optional: 208/60/1 (190-219 volts). Supply must be wired to junction box with terminal block located at rear. Total maximum amps 4.3 per deck.

Optional: 240/60/1 (220-240 volts). Supply must be wired to junction box with terminal block located at rear. Total maximum amps 3.8 per deck.

Optional: 240/50/1 (208-240 volts). Supply must be wired to junction box with terminal block located at rear. Total maximum amps 6.0 per deck

**MISCELLANEOUS**

- If using flex hose connector, the I.D should not be smaller than 3/4" and must comply with ANSI Z 21.69.
- If casters are used with flex hose, a restraining device should be used to eliminate undue strain on the flex hose.
- Clearances from combustibles: Top-0", bottom-0", right side-0" and left-2"
- Recommend - install under vented hood
- Check local codes for fire and sanitary regulations
- If the unit is connected directly to the outside flue, an A.G.A approved down draft diverter must be installed at the flue outlet of the oven
- Oven cannot be operated without fan in operation

**Notice:** Southbend reserves the right to change specifications and product design without notice. Such revisions do not entitle the buyer to corresponding changes, improvements, additions, or replacements for previously purchased equipment.

**OPTIONS AND ACCESSORIES**

- List the voltage, frequency, and amps (see utility information above). \_\_\_VAC, \_\_\_Phase, \_\_\_Hz
- Stainless steel rear jacket
- Stainless Steel oven interior
- NRG system, will make the unit Energy Star approved
- Stainless Steel exterior bottom
- Stainless steel legs with rack pan guide kit
- Casters 4" or 6"
- Marine edge top
- Swivel Caster - front with locks
- Down draft diverter for direct flue
- 3/4" quick disconnect with flexible hose (specify length: 3ft, 4ft, or 5ft)
- 2" air insulation panel (stainless steel only)
- Export crating
- Stainless steel doors

**INTENDED FOR COMMERCIAL USE ONLY.  
NOT FOR HOUSEHOLD USE.**



1100 Old Honeycutt Road, Fuquay-Varina, NC 27526  
(919) 762-1000 www.southbendnc.com