

SOMERSET

Tel: 978.667.3355

800.772.4404

Fax: 978.671.9466

Email: somerset@smrset.com

www.smrset.com



DOUGH ROLLER

CDR-1100

COMPACT 11" (28cm) DOUGH ROLLER

IDEAL FOR PIZZA AS WELL AS:

- Calzones
- Pie Crusts
- Pita Bread
- Flour Tortillas
- Rolled In Dough
- Cookies
- Sheeting
- Sweet Doughs
- Pierogi

HIGHLIGHTS:

- Sheets 500-600 pcs per hour up to 15" (38cm)
- Very compact sheeter with front operation
- Ergonomic design makes it easy and simple to operate
- Sheets dough to a uniform thickness in seconds
- All stainless steel construction offers safety, sanitation, speed, simplicity, durability, and low cost
- Ships standard with synthetic non-stick rollers



SOMERSET INDUSTRIES, INC. • 1 ESQUIRE ROAD • NORTH BILLERICA, MA 01862 • U.S.A.

SOMERSET

DOUGH ROLLER

CDR-1100

FEATURES

- Safety sensors for automatic shutoff
- Compact design, ideal for use in limited space
- Sanitary, heavy duty, all stainless steel welded construction
- Spring loaded scrapers readily removable for easy cleaning
- Simple handle adjustments for exact uniform dough thickness
- Ergonomic design for easy operation
- Large hopper accepts large pieces of dough
- Convenient front operation
- Maintenance free drive mechanism
- Drive mechanism isolated from roller area
- Adjusting stops
- Safe, simple, easy to operate, easy to clean



INDUSTRY USES:

- Pizzerias
- Restaurants
- Institutions
- Schools
- Mexican establishments
- Other ethnic food production
- Cafes
- Bakeries

SPECIFICATIONS

(Specifications subject to change without notice)

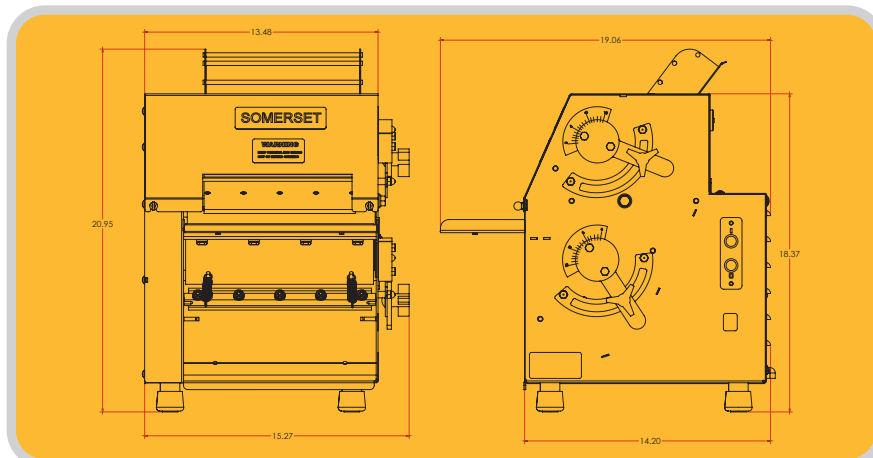

Rollers: 3.5" dia. by 11" length
(8.8cm dia. by 28cm length)

Scrapers: Synthetic, Spring Loaded, Removable

Bearings: Sealed Ball Bearings, Permanently Lubricated

Gear Motor: Heavy Duty 1/4 HP, Single Phase, Maintenance Free, 115v/60Hz or 220v/50Hz

Finishing: All Stainless Steel

Legs: 1" Stainless Steel with Rubber Boots

Shipping Weight: 105lbs (47.7kgs)



MADE IN THE U.S.A. 05.10.12