

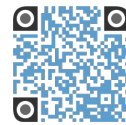

KM-1900S_H(3)

STACKABLE ICE CUBER



KM-1900S_H(3)
03/31/17
Item # 13234

W x D x H
48" x 27^{3/8}" x 36^{7/16}"

KM-1900SAH ★
Air-Cooled 1 Phase
Shown on optional bin: B-900

KM-1900SWH
Water-Cooled 1 Phase

KM-1900SRH ★
Remote Air-Cooled 1 Phase

KM-1900SAH3 ★
Air-Cooled 3 Phase

KM-1900SWH3
Water-Cooled 3 Phase

KM-1900SRH3
Remote Air-Cooled 3 Phase





Item #: _____
Project: _____
Qty: _____
AIA#: _____

Features

▶ Individual crescent cube

▶ Stainless steel evaporator

▶ CycleSaver™ design 

- Up to 1919 lbs. of ice production per 24 hours
- Stackable for 3838 lbs. per 24 hours ice production in the same floor space
- Durable stainless steel exterior
- Protected by H-Guard Plus Antimicrobial Agent 
- EverCheck™ alert system 
- R-404A Refrigerant

Available on Bins:

B-800 **B-1150SS** **B-1500SS** *Top kit may be required.*
B-900 **B-1300SS** **B-1650SS** *See Bin Spec Sheets.*

Warranty:

Valid in United States, Canada, Puerto Rico and U.S. Territories. Contact factory for warranty in other countries.

	Condenser	Model	ICE PRODUCTION				WATER USAGE			ELECTRICAL			Heat Rejection BTU/hr.	Shipping Weight	ENERGY STAR®
			Air / Water Temp Lbs. per 24 hours 70°/ 50°F	90°/ 70°F	Per Cycle Lbs.	Cubes	Potable Gal. per 100 lbs. 90°/ 70°F	Condenser Gal. per 100 lbs. 90°/ 70°F	kWh Used per 100 lbs. 90°/ 70°F	Max. Fuse Size or HACR Circuit Breaker	Amperage	Voltage			
1 Phase	Air-Cooled	KM-1900SAH	1867	1560	45.3	2160	18.8	N/A	4.1	30A	14.4A	208-230V/60/1	23,800	415 lbs.	★
	Water-Cooled	KM-1900SWH	1919	1826	47.5	2160	16.1	98	3.2	30A	12.5A	208-230V/60/1	24,600	415 lbs.	
	Remote Air-Cooled	KM-1900SRH	1857	1640	46.0	2160	20.0	N/A	4.09	30A	14.9A	208-230V/60/1	26,500	415 lbs.	★
3 Phase	Air-Cooled	KM-1900SAH3	1859	1530	45.5	2160	17.0	N/A	4.1	20A	8.59A	208-230V/60/3	23,700	415 lbs.	★
	Water-Cooled	KM-1900SWH3	1912	1850	46.1	2160	17.4	102	3.05	20A	8.4A	208-230V/60/3	25,100	415 lbs.	
	Remote Air-Cooled	KM-1900SRH3	1903	1650	46.8	2160	20.9	N/A	4.04	20A	11.0A	208-230V/60/3	25,700	415 lbs.	

KM Cube Dimensions*

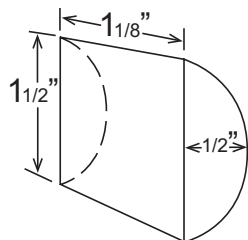

* approximate size in inches, image not to scale

Operating Limits

- Ambient Temp Range 45 - 100°F
- Water Temp Range 45 - 90°F
- Water Pressure 10 - 113 PSIG
- Voltage Range 187 - 253V

Service

- Panels easily removed and all components accessible for service.
- Allow 6" (15 cm) clearance at rear, sides, and top for proper air circulation and ease of maintenance/service.

Plumbing

- Icemaker Water Supply Line: Minimum 3/8" Nominal ID Copper Water Tubing or Equivalent
 - Icemaker Drain Line: Minimum 3/4" Nominal ID Hard Pipe or Equivalent
- Water-Cooled Model (Lines Must Be Independent of Icemaker)
- Condenser Water Supply Line: Minimum 3/8" Nominal ID Copper Water Tubing or Equivalent
 - Condenser Drain/Return Line: Minimum 3/8" Nominal ID Hard Pipe (open drain system) or Copper Water Tubing (closed loop system) or Equivalent



KM-1900S_H(3)

STACKABLE ICE CUBER

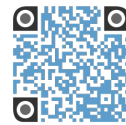

KM-1900S_H(3)
03/31/17
Item # 13234

FRONT VIEW

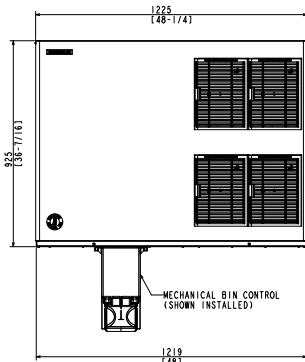

AIR-COOLED

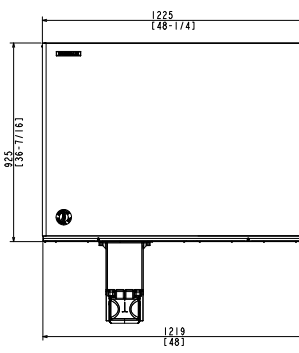

WATER-COOLED

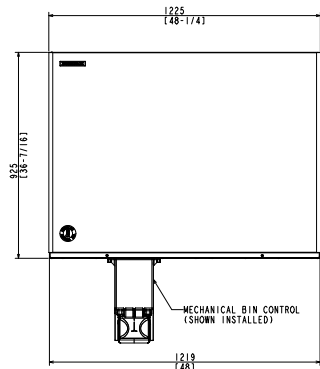

REMOTE AIR-COOLED

SIDE VIEW

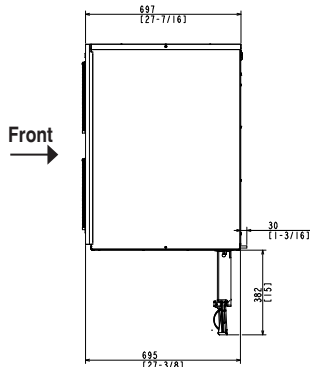

AIR-COOLED

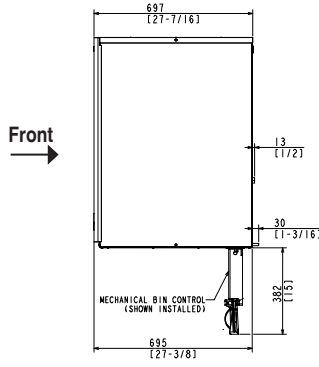

WATER-COOLED

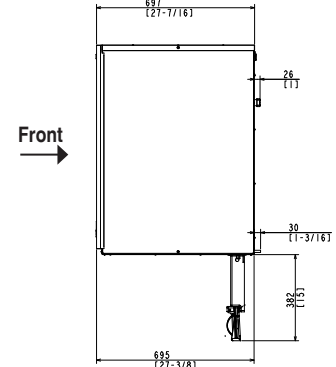

REMOTE AIR-COOLED

REAR VIEW

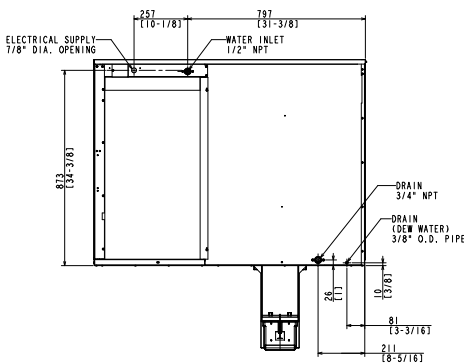

AIR-COOLED

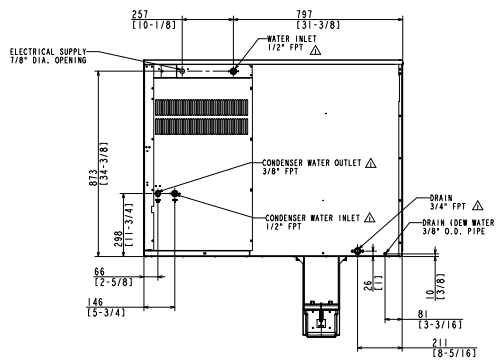

WATER-COOLED

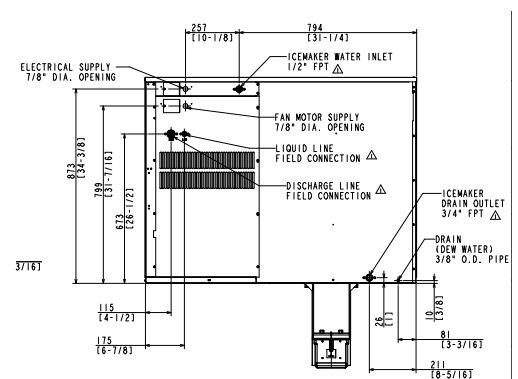

REMOTE AIR-COOLED

BOTTOM VIEW

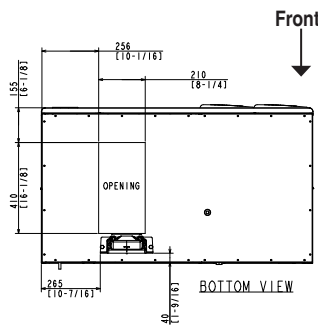

AIR-COOLED
WATER-COOLED

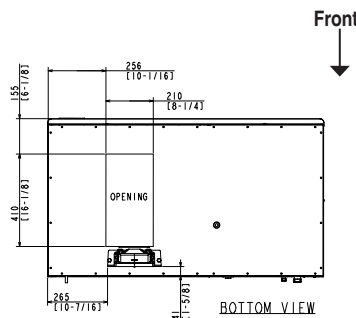

REMOTE AIR-COOLED

URC-22F Remote Condenser (Sold Separately)
(W x D x H) 46 3/8 X 14 1/16 X 40 1/2
For Use with KM-1900SRHS

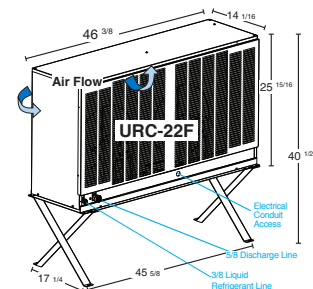

Pre-Charged Tubing Kits

(Sold Separately)
20' R404-20610
35' R404-35610
55' R404-55610



Voltage supply for the URC Remote Condenser is supplied from the Ice Maker. No additional circuit is required.