



**TRUE FOOD SERVICE  
EQUIPMENT, INC.**

2001 East Terra Lane • O'Fallon, Missouri 63366-4434 • (636)240-2400  
 Fax (636)272-2408 • Toll Free (800)325-6152 • Intl Fax# (001)636-272-7546  
 Parts Dept. (800)424-TRUE • Parts Dept. Fax# (636)272-9471 • www.truemfg.com

Project Name: \_\_\_\_\_

Location: \_\_\_\_\_

Item #: \_\_\_\_\_ Qty: \_\_\_\_\_

Model #: \_\_\_\_\_

A/A #

S/S #

Model:  
**TPP-93D-2**

**Food Prep Table:**  
*Drawered Pizza Prep Table*



**TPP-93D-2**

- ▶ True's pizza prep tables are designed with enduring quality that protects your long term investment.
- ▶ Oversized, environmentally friendly (R134A) forced-air refrigeration system holds 33°F to 41°F (.5°C to 5°C).
- ▶ Complies with and listed under ANSI/NSF-7.
- ▶ All stainless steel front, top and ends. Matching aluminum finished back.
- ▶ Stainless steel, patented, foam insulated flat lids keep pan temperatures colder, lock in freshness, and minimize condensation.
- ▶ Interior - attractive, NSF approved, clear coated aluminum liner. Stainless steel floor with covered corners.
- ▶ Extra-deep 19½" (496 mm) full length removable cutting board included. Sanitary, high density, NSF approved white polyethylene provides tough preparation surface.
- ▶ Heavy duty, PVC coated wire shelves (door sections).
- ▶ Each drawer accommodates two (2) full size 12"L x 20"W x 8"D (305 mm x 508 mm x 204 mm) pans (sold separately).



Scan code for video

Door or drawer assemblies can be located in any section of the cabinet. Location of door/drawers must be indicated at time of ordering.

**ROUGH-IN DATA**

Chart dimensions rounded up to the nearest 1/8" (millimeters rounded up to next whole number).

Specifications subject to change without notice.

Model	Doors	Drawers	Shelves	Pans (top)	Cabinet Dimensions (inches) (mm)			HP	Voltage	Amps	NEMA Config.	Cord Length (total ft.) (total m)	Crated Weight (lbs.) (kg)
					L**	D†	H*						
TPP-93D-2	2	2	4	12	93¼	33⅝	35⅜	½	115/60/1	9.7	5-15P	7	630
					2369	854	899	½	230-240/50/1	4.2	▲	2.13	286

\*\* Width does not include ¼" (7 mm) each side for cutting board brackets and thumb screws.

† Depth does not include 1" (26 mm) for rear bumpers and 1½" (39 mm) for cutting board.

\* Height does not include 6¼" (159 mm) for castors or 6" (153 mm) for optional legs.

▲ Plug type varies by country.



APPROVALS:

AVAILABLE AT:

Model:  
**TPP-93D-2**

# Food Prep Table: Drawered Pizza Prep Table



## STANDARD FEATURES

### DESIGN

- True's commitment to using the highest quality materials and oversized refrigeration systems provides the user with colder product temperatures, lower utility costs, exceptional food safety and the best value in today's food service marketplace.

### REFRIGERATION SYSTEM

- Factory engineered, self-contained, capillary tube system using environmentally friendly (CFC free) 134A refrigerant.
- Oversized, factory balanced refrigeration system with guided airflow to provide uniform temperature in food pan rail and cabinet interior.
- Forced-air design holds 33°F to 41°F (.5°C to 5°C) product temperature in food pans and cabinet interior. Complies with and listed under ANSI/ NSF-7.
- Condensing unit accessed from behind front removable panel, slides out for easy maintenance.

### CABINET CONSTRUCTION

- Exterior - stainless steel front, top and ends. Matching aluminum finished back.
- Interior - attractive, NSF approved, clear coated aluminum liner. Stainless steel floor with coved corners.
- Insulation - entire cabinet structure, solid doors, and drawer facings are foamed-in-place using a high density, polyurethane insulation that has zero ozone depletion potential (ODP) and zero global warming potential (GWP).
- 5" (127 mm) diameter stem castors. 36" (915 mm) work surface height.

### DOORS / DRAWERS

- Door or drawer assemblies can be located in any section of the cabinet. Location of door/drawers must be indicated at time of ordering.

- Doors constructed of stainless steel exterior with white aluminum liner to match cabinet interior. Drawers have stainless steel exterior facings and liners with stainless steel frames.
- Each door and drawer fitted with 12" (305 mm) long recessed handle that is foamed-in-place with a sheet metal interlock to ensure permanent attachment.
- Positive seal doors swing within cabinet dimensions.
- Magnetic door/drawer gaskets of one piece construction, removable without tools for ease of cleaning.
- Heavy-duty stainless steel drawer slides and rollers. Removable without tools for easy cleaning.
- Each drawer accommodates two (2) full size 12"L x 20"W x 8"D (305 mm x 508 mm x 204 mm) food pans (sold separately). Drawer will support varying pan configurations with pan dividers bars (drawer pans and divider bars optional).

### SHELVING

- Four (4) adjustable, heavy duty PVC coated wire shelves. Two (2) right and two (2) left section shelf dimensions are 23 5/8" L x 28"D (601 mm x 712 mm). Center door shelf dimensions are 25 1/2" L x 28"D (648 mm x 712 mm). Four (4) chrome plated shelf clips included per shelf.
- Shelf support pilasters made of same material as cabinet interior; shelves are adjustable on 1/2" (13 mm) increments.

### MODEL FEATURES

- Evaporator is epoxy coated to eliminate the potential of corrosion.
- Extra-deep 19 1/2" (496 mm), full length removable cutting board included. Sanitary, high-density, NSF approved white polyethylene provides tough preparation surface.

- Stainless steel, patented, foam insulated flat lids keep pan temperatures colder, lock in freshness, and minimize condensation.
- Refrigerated pan rail comes standard with twelve (1/2 size) 12 3/4" L x 6 1/4" W x 6"D (324 mm x 159 mm x 153 mm) NSF approved clear polycarbonate insert pans.
- NSF-7 compliant for open food product.

### ELECTRICAL

- Unit completely pre-wired at factory and ready for final connection to a 115/60/1 phase, 15 amp dedicated outlet. Cord and plug set included.



115/60/1  
NEMA-5-15R

### OPTIONAL FEATURES/ACCESSORIES

Upcharge and lead times may apply.

- 230 - 240V / 50 Hz.
- 6" (153 mm) standard legs.
- 6" (153 mm) seismic/flanged legs.
- 4" (102 mm) diameter castors.
- 3" (85 mm) diameter castors.
- 2 1/2" (64 mm) diameter castors.
- Barrel locks available for door sections. Requires one per door (factory installed).
- Garnish racks.
- Half bun tray rack (door section only). Holds up to eleven 18"L x 26"D (458 mm x 661 mm) sheet pans (sold separately).
- 19 1/2" (496 mm) deep, 1/2" (13 mm) thick, composite cutting board.
- Pan dividers.
- Exterior round digital temperature display (factory installed).

## PLAN VIEW

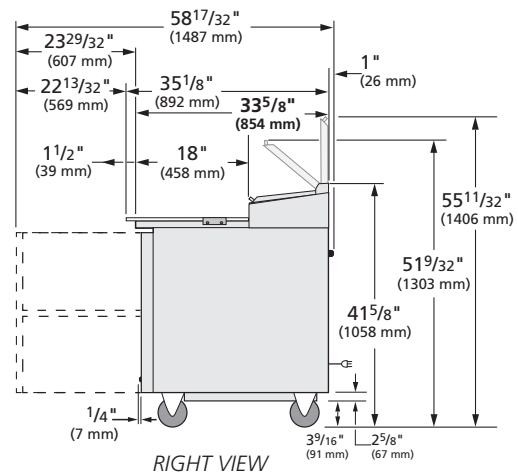
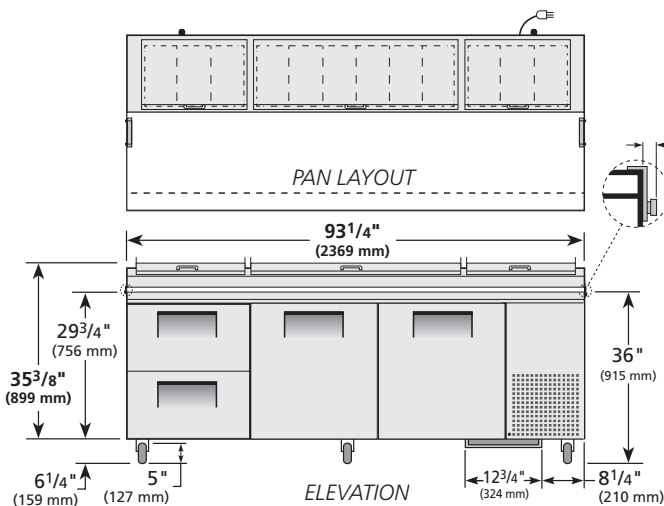

**WARRANTY\***  
Three year warranty on all parts and labor and an additional 2 year warranty on compressor.  
(U.S.A. only)

METRIC DIMENSIONS ROUNDED UP TO THE NEAREST WHOLE MILLIMETER

SPECIFICATIONS SUBJECT TO CHANGE WITHOUT NOTICE



Model	Elevation	Right	Plan	3D	Back
TPP-93D-2	TFQY73E	TFQY70S	TFQY73P	TFQY733	

## TRUE FOOD SERVICE EQUIPMENT

2001 East Terra Lane • O'Fallon, Missouri 63366-4434 • (636)240-2400 • Fax (636)272-2408 • Toll Free (800)325-6152 • Intl. Fax# (001)636-272-7546 • www.truefmfg.com

\*RESIDENTIAL APPLICATIONS: TRUE assumes no liability for parts or labor coverage for component failure or other damages resulting from installation in non-commercial or residential applications.