

NZ Distributor: **TRADESMART**



CONTRACTOR TOUGH



AEC Factory & Headquarters in Paragould, Arkansas

ABOUT ALLEN ENGINEERING CORPORATION

Allen Engineering Corp. (AEC) was founded in 1964 by Dewayne and Mary Ann Allen in Piggott, Arkansas as a Ready Mix Concrete Operation.

The company evolved and changed from a Ready Mix and Aggregate Producer (with six locations in Arkansas and Missouri) to a Concrete Pumping operation and eventually into a Concrete Contractor.

In 1977, Dewayne manufactured Allen's first piece of concrete equipment, the Razorback® Truss Screed, in an old Truck Repair Shop in Paragould, Arkansas.

Today, AEC is a designer, manufacturer, distributor, and marketer of the Allen® line of Concrete and Related Equipment that is sold across the country and around the world.

Over Fifty Years later, AEC is still a Family Owned and Operated, Arkansas Based Business with Jay Allen (President and second generation) running the daily operations. Dewayne and Mary Ann Allen still serve on the company's Board of Directors offering guidance and over-sight.

The Allen product line represents a complete system for the placing, finishing, and paving of all types of concrete.

We design, manufacture, and assemble each piece of Allen Equipment to be "Contractor Tough" so it can stand up to the most challenging job-site conditions created by concrete contractors.

Allen Engineering has maintained a leading role in the evolution of high tolerance concrete floors (measured by F Numbers) around the world. Allen Engineering was the first company to put Floating Discs (Pans) under a Ride-On Power Trowel which led to a significant improvement in concrete floor flatness. Today, Allen counts many of the major concrete contractors from around the world as satisfied owners of Allen Equipment.





Team Allen in the AEC Factory

The majority of Allen Equipment is manufactured in the company's 173K square foot manufacturing and distribution facility located in Paragould. The factory occupies the same site on Fifth Street as the ready mix concrete operation that Dewayne Allen purchased in 1968.

Allen Engineering is a fully integrated equipment designer and manufacturer. Our in-house operations include equipment design, engineering, prototyping, testing, CNC machining, metal fabrication, laser metal cutting, welding, powder coat painting, assembly, warehousing, and distribution.

AEC employs a sales and marketing team that includes a full-time, job-site focused sales force and well as a network of independent sales representative agencies. Allen Concrete Equipment is sold and rented worldwide in over 90 countries through a network of concrete-focused dealers, rental centers, and distributors.



VISION

To be the premier, global provider of concrete and related equipment solutions for professional contractors.

MISSION

We provide innovative concrete and related equipment that solves professional contractor's major quality and productivity issues on their jobsites.

CORE VALUES

Safety: Priority One

People: Our most valuable asset

Quality: Our most important attribute

Innovation: Our focus with our products and processes

Teamwork: The way we work and think

Customer/Contractor Focused:
Our key driver

Honest: The only way we do business



REASONS TO BUY ALLEN EQUIPMENT

OUR PASSION IS QUALITY

Every member of Team Allen is focused on the total quality and reliability of every machine we make.

OUR FOCUS IS INNOVATION

We are committed to constantly developing, innovating and improving our full line of equipment.

FAMILY OWNED

The owners are directly involved in the everyday operation of the business focusing daily on Total Customer Satisfaction.

CONTRACTOR FOCUSED

Our top priority for over 50 years has been to service and support the professional contractor.

TWO-YEAR WARRANTY

We back up what we make and sell so you can have complete confidence in our equipment.



Allen Concrete College (ACC) combines a classroom seminar and hands-on training in concrete placing and finishing techniques to produce high f-number floors. ACC is a great opportunity for Allen Dealers and contractors to learn how to increase the flatness and levelness of floors, the basics of concrete flooring mix design and the F-Number System.

To register for our next class, go to the online application form at www.alleneng.com with complete information on the date and costs.



ALLEN® PRODUCTS ARE COVERED UNDER ONE OR MORE OF THE FOLLOWING PATENT NUMBERS: 465897S; 466,909; 5,816,739; 5,803,658; 5,890,833; 474,203; 5,988,939; 6,019,433; 5,934,823; 5,988,938; 5,967,696; 6,053,660; 6,089,787; 6,106,193; 6,048,130; 6,019,545; 6,089,786; 6,582,153; 6,857,815B2; 6,955,404; 7,108,449B1; 7,114,876B1; 7,316,523B1; 7,690,864; 8,360,680; 9,068,300; 9,068,301; 10,100,537; With other Patents Pending

PLACING

POWER BUGGIES

Rubber Tire Buggies 6 - 7

Track Buggies 8 - 11

TRUSS SCREEDS

Steel Truss Screeds 12 - 13

Aluminum Truss Screeds 13

Truss Screed Accessories 14 - 15

MAGIC SCREED® 16

ROLLER TUBE FINISHERS

Hydraulic Drive 17

Engine Drive 17

CONCRETE VIBRATORS

Gasoline Backpack 18

Electric Flex-Shaft 18

Power Vibe Series 18

FINISHING

PERVIOUS CONCRETE & FLOOR FLATNESS HAND TOOLS 19

WALK-BEHIND TROWELS

Professional // PRO Series 20

Value Premium // VP Series 21

RIDING TROWELS

Hydra Drive Extreme // HDX Series 22 - 23

High Performance // HP Series 24

Mechanical Super Pro // MSP Series 25 - 27

Mechanical Pro // MP Series 28 - 29

STEEL FLOAT PANS & TROWEL BLADES 30

PAVING

POWER SPRAYERS 31

TRIPLE ROLLER TUBE PAVERS 32

BRIDGE DECK FINISHERS 33

WORK BRIDGES 34

VERSATILE LIGHT RAIL PAVERS 35

POLYESTER SLIP FORM PAVERS 35

PROUD MEMBERS OF



NEED MORE INFO?

VISIT OUR WEBSITE

WWW.ALLENENG.COM

FOLLOW US ON



GIVE US A CALL

800.643.0095 (USA ONLY) / 870.236.7751

ALLEN RUBBER TIRE POWER BUGGIES

The sixteen cubic foot AR16 and the twenty-one cubic foot AR21 have earned their rank as the standard by which all power buggies are judged. The standard high-strength, high-density polyethylene bucket is the industry's thickest and most durable. And standard features like heavy-duty hydraulic wheel motors, steel raceways for hydraulic hose protection and optional foam-filled tires ensure the AR16 and AR21 power buggies will operate for the duration under tough conditions. Our propane-powered buggy is perfect for indoor or around in-the-dry jobsites where air quality is an issue.

AR16



Huge 16 cubic foot capacity, heavy-duty poly dump bucket

Hydraulic dump action

Foam filled tires

Solid 2" thick steel frame



AR16P



CARB
California Air Resources Board
Compliant with CARB and EPA Standards



AR21



POWERED by
HONDA

DESCRIPTION	AR16	AR16P 	AR21
ENGINE	Honda GX390 (389 cc)	Honda GX390 (389 cc)	Honda GX630 (688 cc)
HORSEPOWER CLASS	13 hp (9.6 kW)	13 hp (9.6 kW)	20 hp (14.9 kW)
STARTER	Recoil or Electric	Electric	Electric
FUEL TYPE	Gasoline	Propane	Gasoline
FUEL CAPACITY	1.7 gal (6 L)	8 gal	2.1 gal (8 L)
TOP SPEED	7 mph (11.2 kph)	7 mph (11.2 kph)	5.9 mph (9.5 kph)
PAYLOAD	2500 lbs (1134 kg)	2500 lbs (1134 kg)	3200 lbs (1451 kg)
BUCKET CAPACITY	16 cu ft (0.45 cu m)	16 cu ft (0.45 cu m)	21 cu ft (0.59 cu m)
LIFT CYLINDER DIAMETER	2 in (51 mm)	2 in (51 mm)	2.5 in (63.5 mm)
DUMP / RETURN SPEED EMPTY	5 Seconds	5 Seconds	8 Seconds
WHEELBASE	40 in (102 cm)	40 in (102 cm)	40 in (102 cm)
WEIGHT	1300 lb (590 kg)	1370 lb (590 kg)	1405 lb (637 kg)
DIMENSIONS (L x W x H)	97 x 47 x 50 in (246 x 119 x 127 cm)	97 x 47 x 64 in (246 x 119 x 162 cm)	97 x 47 x 50 in (246 x 119 x 127 cm)

ALLEN TRACK DRIVE POWER BUGGIES

The Allen Track Drive Power Buggies provide excellent traction on grades, inclines, and soft soils. The buggies providing excellent power, heavy load carrying capacity and up to sixteen cubic foot bucket volumes. The AT14S even has a 180-degree pivoting dump that will allow you to place your material exactly where you need it.

AT16

Largest track buggy payload available at 2,500 lbs

Two work lights for greater work site visibility

Heavy-duty poly dump bucket for long life

Hydraulic dump action with 6" of ground clearance when fully dumped

Rubber tracks for extra load capacity and traction

POWERED BY
KOHLER



Steel frame design for improved strength and performance.



Rear platform folds to allow for easier transport between jobsites or storage.

AT14F



POWERED by HONDA™



Two servo levers control the direction of the machine, and they automatically reset to stop in case of emergency.



Engine cover folds back to provide convenient access to the engine, gasoline tank, battery, and filters.



DESCRIPTION	AT14F	AT16
ENGINE	Honda GX630 (688 cc)	Kohler CV740 (725 cc)
HORSEPOWER CLASS	20 hp (14.9 kW)	25 hp (18.6 kW)
STARTER	Electric	Electric
FUEL TYPE	Gasoline	Gasoline
FUEL CAPACITY	3 gal (11.35 L)	6 gal (22.7 L)
TOP SPEED	WORK: 4 mph (6 kph) TRAVEL: 6 mph (10 kph)	WORK: 4 mph (6 kph) TRAVEL: 6 mph (10 kph)
PAYLOAD	2100 lb (952 kg)	2500 lb (1135 kg)
BUCKET CAPACITY	14 cu ft (0.39 cu m)	16 cu ft (0.45 cu m)
DUMP ANGLE	90°	90°
PIVOT ANGLE	0°	0°
WEIGHT	1420 lb (644 kg)	1475 lb (669 kg)
DIMENSIONS (L x W x H)	98 x 31.5 x 52.5 in (248.9 x 80 x 133.4 cm)	102.5 x 35.6 X 65.25 in (260 x 90.4 x 165.7 cm)

AT14S



POWERED by
HONDA™



Two servo levers control the direction of the machine, and they automatically reset to stop in case of emergency.



Engine cover folds back to provide convenient access to the engine, gasoline tank, battery, and filters.



DESCRIPTION	AT14S
ENGINE	Honda GX630 (688 cc)
HORSEPOWER CLASS	20 hp (14.9 kW)
STARTER	Electric
FUEL TYPE	Gasoline
FUEL CAPACITY	3 gal (11.35 L)
TOP SPEED	WORK: 4 mph (6 kph) TRAVEL: 6 mph (10 kph)
PAYLOAD	1785 lb (810 kg)
BUCKET CAPACITY	14 cu ft (0.39 cu m)
DUMP ANGLE	90°
PIVOT ANGLE	180°
WEIGHT	1540 lb (699 kg)
DIMENSIONS (L x W x H)	98.4 x 33.3 x 54 in (250 x 81.3 x 137.1 cm)

AT12L



POWERED by **HONDA**



Two servo levers control the direction of the machine, and they automatically reset to stop in case of emergency.



Engine cover folds back to provide convenient access to the engine, gasoline tank, battery, and filters.

DESCRIPTION	AT12L
ENGINE	Honda GX630 (688 cc)
HORSEPOWER CLASS	20 hp (14.9 kW)
STARTER	Electric
FUEL TYPE	Gasoline
FUEL CAPACITY	3 gal (11.35 L)
TOP SPEED	WORK: 4 mph (6 kph) TRAVEL: 6 mph (10 kph)
PAYLOAD	1785 lb (810 kg)
BUCKET CAPACITY	12 cu ft (0.34 cu m)
DUMP ANGLE	90°
WEIGHT	1385 lb (628 kg)
DIMENSIONS (L x W x H)	103 x 33 x 50 in (261.6 x 83.8 x 127 cm)

STEEL ENGINE DRIVEN TRUSS SCREED

The Allen® Razorback® Truss Screed is the contractor's preferred brand when high tolerance F_L Numbers are specified on concrete floors and pavements. For more than 40 years, Allen Truss Screeds have set the industry's standard for precision levelness, rigidity and durability.

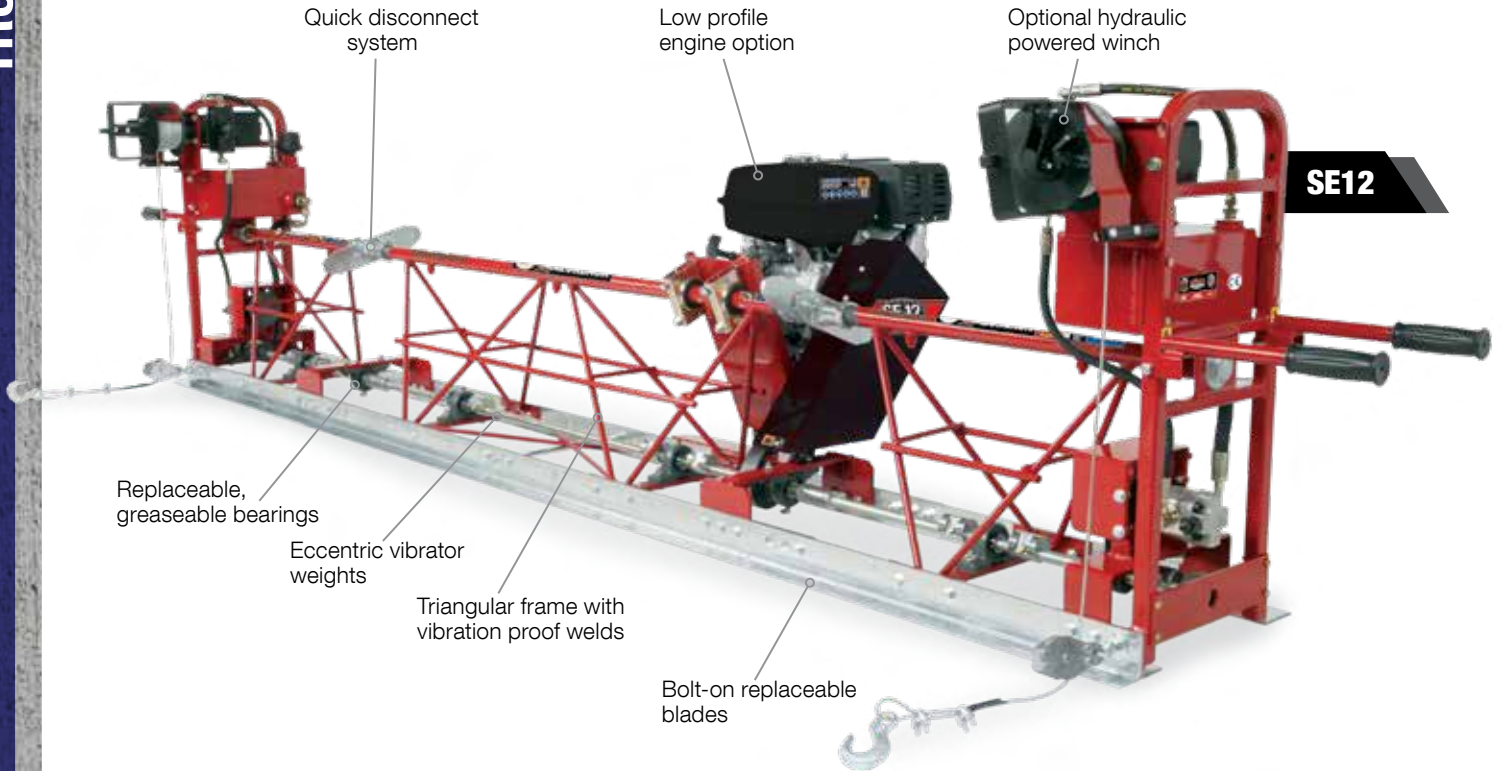

DESCRIPTION	SE12
FRAME CONSTRUCTION	Steel
VIBRATION SYSTEM	Eccentric Shaft
ENGINE (WIDTHS LESS THAN 50')	Honda GX270 - 9 hp (6.7 kW)
ENGINE (WIDTHS MORE THAN 50')	Honda GX340 - 11 hp (8.2 kW)
SECTION LENGTHS / WEIGHTS	
2 FT (.61 M)	37 lb (17 kg)
2.5 FT (.76 M)	46 lb (20 kg)
5 FT (1.5 M)	90 lb (41 kg)
7.5 FT (2.3 M)	135 lb (61 kg)
10 FT (3.1 M)	180 lb (82 kg)
MAXIMUM WIDTH	65 ft (19.8 m)
LOWEST CONCRETE SLUMP	3 in (7.6 cm)
MAXIMUM CONSOLIDATION DEPTH	8 in (20.3 cm)
BLADES	10 Gauge Galvanized Steel



STEEL AIR VIBRATION TRUSS SCREED

Our air-driven screeds feature precision engineered naval bronze piston vibrators that are rust resistant, non-sticking and free-starting.

DESCRIPTION	SA12
FRAME CONSTRUCTION	Steel
VIBRATION SYSTEM	Dual Air
SECTION LENGTHS / WEIGHTS	
2 FT (.61 M)	37 lb (17 kg)
2.5 FT (.76 M)	47 lb (21 kg)
5 FT (1.5 M)	93 lb (42 kg)
7.5 FT (2.3 M)	138 lb (63 kg)
10 FT (3.1 M)	186 lb (84 kg)
MAXIMUM WIDTH	65 ft (19.8 m)
LOWEST CONCRETE SLUMP	2 in (5.1 cm)
MAXIMUM CONSOLIDATION DEPTH	12 in (30.5 cm)
BLADES	10 Gauge Galvanized Steel

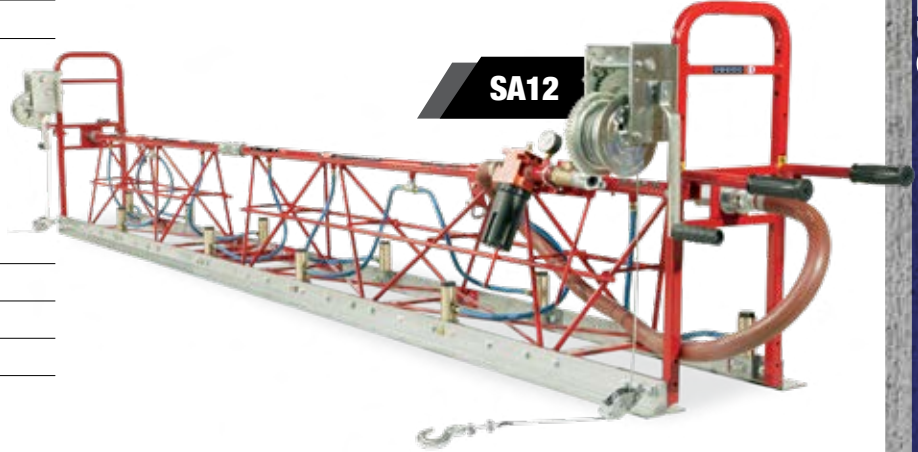

ALUMINUM ENGINE DRIVEN TRUSS SCREED

A lighter weight, extremely portable version of our legendary steel screeds, the engine-driven aluminum truss screed is perfect for the pickup truck portability to job-sites.

DESCRIPTION	AE12
FRAME CONSTRUCTION	Aluminum
VIBRATION SYSTEM	Eccentric Shaft
ENGINE (WIDTHS LESS THAN 50')	Honda GX270 - 9 hp (6.7 kW)
ENGINE (WIDTHS MORE THAN 50')	Honda GX340 - 11 hp (8.2 kW)
SECTION LENGTHS / WEIGHTS	
2 FT (.61 M)	24 lb (11 kg)
2.5 FT (.76 M)	34 lb (15 kg)
5 FT (1.5 M)	60 lb (27 kg)
7.5 FT (2.3 M)	90 lb (41 kg)
MAXIMUM WIDTH	50 ft (15.2 m)
LOWEST CONCRETE SLUMP	4 in (10.2 cm)
MAXIMUM CONSOLIDATION DEPTH	6 in (15.2 cm)
BLADES	12 Gauge Galvanized Steel

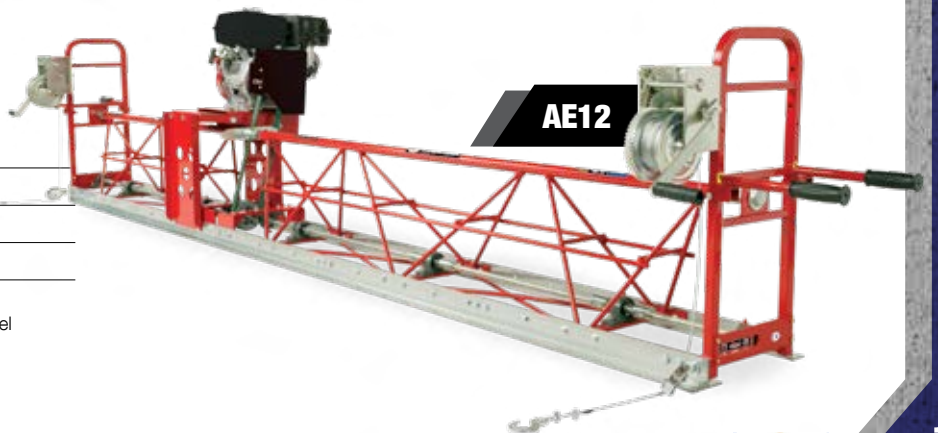

POWERED by
HONDA

TRUSS SCREED ACCESSORIES

We have many special application truss screed accessories designed to make your Allen Razorback® Truss Screed a highly useful and versatile screeding tool. From infrastructure to agriculture applications, we have designed and tested hundreds of customized Allen Truss Screed Accessories over our 40 plus years of truss screed manufacturing experience.



ADJUSTABLE END BRACKETS

Rides on forms or wall brackets and can be adjusted both horizontally and vertically. Available with and without rollers. (shown with rollers)



BRIDGE DECK HANDLE

Used to straddle obstacles associated with slab on grade, bridge and highway construction. Adjustable in both horizontal and vertical direction.



STRADDLE BRACKET

Fits between sections of screed when it is necessary to straddle an object in the path of the screed pour. (Air Vibration Screeds Only)

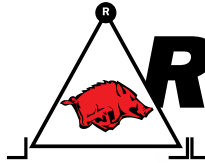

RAZORBACK

SCREED CART

Gets you around the job site quickly and easily.



CROWN/INVERT BRACKET

Attaches in the center between two or more sections of screeds. For use when crown or invert exceeds one-quarter inch per one foot.



PIVOT BRACKET

This unique accessory enables a contractor to use a truss screed on a round tank bottom, such as sewage treatment plant tanks. The pivot bracket can cut down on labor and finishing costs.



MAGIC SCREED®

The Magic Screed is a precision engineered, lightweight wet screed for single operator strike-off of concrete. Fast and easy to use, this high-frequency screed provides uniform distribution over the entire blade length, enhancing structural integrity of the concrete through consolidation.



POWERED by **HONDA**



The unique, patented blade simultaneously cuts and smooths concrete.



Handles can be adjusted for height, twisted to the inside or outside and have the angle adjusted for maximum ergonomic support.

DESCRIPTION	HD6060	HD7070
ENGINE	Honda GX35 (35cc)	Honda GX35 (35cc)
HORSEPOWER CLASS	1.5 hp (1.1 kW)	1.5 hp (1.1 kW)
HANDLES	Fixed	Adjustable
WEIGHT	30 lb (13.5 kg)	30 lb (13.5 kg)

BLADE WIDTHS	BLADE WEIGHTS
4 ft (1.22 m)	6 lb (3 kg)
6 ft (1.83 m)	10 lb (4 kg)
8 ft (2.44 m)	13 lb (6 kg)
10 ft (3.05 m)	16 lb (7 kg)
12 ft (3.66 m)	20 lb (9 kg)
14 ft (4.27 m)	23 lb (11 kg)
16 ft (4.88 m)	27 lb (12 kg)

HYDRAULIC ROLLER TUBE FINISHER

For applications where more power and a larger tube is needed. This unit is great for slope pours and pervious concrete jobs.



FEATURES

- Webster Control Valve
- 4.5 GPM hydraulic system at 2500 PSI
- 50-foot Quick Disconnect Hose is standard
- Removable frame for maintenance
- Hydraulic cooling system with 12-volt fan

POWERED BY
KOHLER

DESCRIPTION	RTF HPU
ENGINE	Kohler CH440 (429 cc)
HORSEPOWER CLASS	14 hp (10.4 kW)
TUBE DIAMETER	6.5 in (16.5 cm)
TUBE LENGTHS AVAILABLE	6 - 26 ft (1.83 - 7.93 m)

ENGINE DRIVEN ROLLER TUBE FINISHER

This portable and powerful solution strikes off concrete fast and accurately.



FEATURES

- Optional counter weight kit available
- High-Speed 300 RPM Gear Box
- Will drive all 4.5" Tubes up to 24'
- Variable speed control handle
- Handles swivel for ease of use and easy storage



DESCRIPTION	RTF HPU
ENGINE	Honda GXH50 (49 cc)
HORSEPOWER CLASS	2.5 hp (1.9 kW)
TUBE DIAMETER	4.5 in (10.1 cm)
TUBE LENGTHS AVAILABLE	6 - 24 ft (1.83 - 7.32 m)

GASOLINE BACKPACK VIBRATORS

Our backpack vibrator allows you to go anywhere without worrying about the need for electricity. It features a “speed-up” transmission that allows the engine to run at low rpm’s and still produce high vibrations per minute.



This unit makes changing heads and shafts easy via our quick disconnect system.



DESCRIPTION	BP50
ENGINE	Honda GXH50 (49cc)
HORSEPOWER CLASS	2.5 hp (1.9 kW)
VIBRATIONS PER MINUTE	11,000 - 12,000
FLEXIBLE SHAFT LENGTHS	2 - 21 ft (.6 - 6.4 m)
VIBRATOR HEAD MATERIAL	Steel or Rubber

POWERED by HONDA™

ELECTRIC FLEX-SHAFT VIBRATORS

These lightweight models feature high vibrations per minute in an easy-to-carry size, interchangeable head and shafts via our quick disconnect system, and a convenient shoulder strap for operator comfort.



Rubber coated heads vibrate concrete without damaging epoxy coated rebar.

DESCRIPTION	FSVE
POWER	115 Volt Grounded
MOTORS AVAILABLE	1.25 - 3.25 hp (.93 - 2.4 kW)
VIBRATIONS PER MINUTE	11,000 - 12,000
FLEXIBLE SHAFT LENGTHS	2 - 21 ft (.6 - 6.4 m)
VIBRATOR HEAD MATERIAL	Steel or Rubber

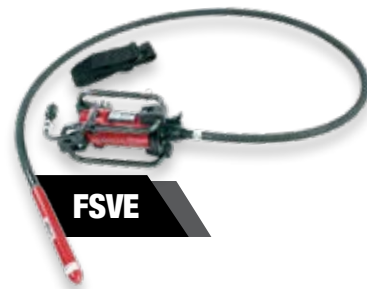

POWER VIBE SERIES VIBRATORS

These concrete vibrators are the ultimate in hand-held gasoline powered vibrators. Both are lightweight, but powerful and provide excellent consolidation of concrete.



POWER VIBE PRO



POWER VIBE

POWERED by HONDA™

DESCRIPTION	POWER VIBE	POWER VIBE PRO
ENGINE	Honda GX35 (35 cc)	Honda GX35 (35 cc)
HORSEPOWER CLASS	1.5 hp (1.1 kW)	1.5 hp (1.1 kW)
SHAFT LENGTHS	2 - 10 ft (.6 - 3 m)	1 ft (.6 m) Flexible shaft with rigid shaft extension
STEEL VIBRATORS HEAD SIZES	1 - 2 in (2.5 - 5.1 cm)	2 in (5.1 cm)
RUBBER VIBRATOR HEAD SIZES	2 in (5.1 cm)	2 in (5.1 cm)

PERVIOUS CONCRETE TOOLS

Use these tools when consolidating and jointing pervious concrete. These unique hand tools are a part of Allen's Total Tube Finishing System. Handles not included.



FLOOR FLATNESS HAND TOOLS

Checked to exact flatness tolerances, our extruded magnesium Allen Hand Tools are specifically designed to improve floor or pavement levelness. Each tool comes standard with three 6' (1.8 m) snap-together aluminum handles, the equalizer, outriggers and turn buckle.



BUMP CUTTER

Cuts down bumps and fills low areas after concrete slab has been floated.



CHECK ROD

Reduces bumps and fills low areas while the concrete is still plastic.



CHANNEL FLOAT

Use in lieu of traditional bull float for flatter floors and pavements.



Our hand tools are available with either the Rock-It (left) or Equalizer Pitch (right) adjusting head for precise, even control.

DESCRIPTION	TOOLS WIDTHS	DIMENSIONS
HTCF CHANNEL FLOAT	5 - 12 ft (1.5 - 3.7 m)	6 in (15.2 cm)
HTCR CHECK ROD	8 - 16 ft (2.4 - 4.9 m)	2 x 4 in (5.1 x 10.2 cm)
HTBC BUMP CUTTER	8 - 16 ft (2.4 - 4.9 m)	2 x 4 in (5.1 x 10.2 cm)

PRO WALK-BEHIND TROWELS

Allen Pro-Series Walkers feature precision engineered gearboxes for long, trouble-free life. We use cast iron spiders, pressure plates and lift levers for long wear and continuous service, and we precision machine our trowel arms and spiders to such close tolerances that our trowels do not require bushings.



POWERED by **HONDA**



Fine pitch handles use a twist action to control blade pitch from flat to 28° and anything in between.



Positive pitch handles use a ratcheting action to provide easy adjustment with the push or pull of a lever.



UNIQUE PATENTED EDGING WALKER

This unique 36" rotating edge ring can only be found on PRO436 E. It is perfect for troweling along the edges of walls or around protruding pipe and conduit.

DESCRIPTION	PRO436	PRO436E	PRO436DF 	PRO446	PRO446TC
ENGINE	Honda GX160 (163 cc)	Honda GX270 (270 cc)	Kohler CH395 dual-fuel	Honda GX270 (270 cc)	Honda GX390 (389 cc)
HORSE POWER CLASS	5.5 hp (4.1 kW) or 9 hp (6.7 kW)	9 hp (6.7 kW)	9.5 hp (7.1 kW)	9 hp (6.7 kW)	13 hp (9.7 kW)
FUEL TYPE	Gasoline	Gasoline	Propane and Gasoline	Gasoline	Gasoline
ROTOR DIAMETER	36 in (92 cm) 4-blades	36 in (92 cm) 4-blades	36 in (92 cm) 4-blades	46 in (117 cm) 4-blades	46 in (117 cm) 4-Blades
MAXIMUM ROTOR SPEED	120 rpm	120 rpm	120 rpm	120 rpm	180 rpm
TROWEL ARMS & SPIDER	Standard Duty	Standard Duty	Standard Duty	Standard Duty	Super Duty
WEIGHT	186 lb (89 kg) or 222 lb (101 kg)	198 lb (89 kg)	275 lb (125 kg)	250 lb (113 kg)	315 lb (142 kg)
DIMENSIONS (L x W x H)	72 x 38 x 36 in (177.8 x 96.5 x 91.5 cm)	84 x 36 x 38 in (213.4 x 91.5 x 96.5 cm)	72 x 38 x 36 in (177.8 x 96.5 x 91.5 cm)	78 x 48 x 39 in (198.1 x 121.9 x 99 cm)	78 x 48 x 39 in (198.1 x 121.9 x 99 cm)

NZ Distributor

TRADESMART

VP WALK BEHIND TROWELS

Our Value Premium (VP) walk-behind trowels are our slightly lighter weight but feature-rich and professional quality walkers. Available with either fine-pitch or positive pitch blade controls and a 24-inch edger model, these are the dependable workhorses for your concrete finishing needs.



Unique folding compact walker with 24" diameter rotating guard wheel to allow for edging against walls, pipes and other obstructions.



Positive pitch handles provide easy adjustment with the push or pull of a lever.



Fine pitch handles twist to provide infinite blade pitch settings from flat to 28°.

DESCRIPTION	VP424	VP436	VP446
ENGINE	Honda GX120 (118 cc)	Honda GX160 (163 cc)	Honda GX270 (270 cc)
HORSE POWER CLASS	4 hp (3 kW)	5.5 hp (4.1 kW) or 9 hp (6.7 kW)	9 hp (6.7 kW)
ROTOR DIAMETER	24 in (61 cm) 4-blades	36 in (92 cm) 4-blades	46 in (117 cm) 4-blades
MAXIMUM ROTOR SPEED	135 rpm	150 rpm	150 rpm
TROWEL ARMS & SPIDER	Standard Duty	Standard Duty	Standard Duty
WEIGHT	122 lb (55 kg)	172 lb (78 kg) or 184 lb (87.9 kg)	210 lb (95 kg)
DIMENSIONS (L x W x H)	65 x 24 x 43 in (165.1 x 61.0 x 109.2 cm)	75 x 36 x 43 in (190.5 x 91.5 x 109.2 cm)	82 x 46 x 43 in (2,083 x 1,168 x 1,092 cm)

HYDRA DRIVE EXTREME RIDERS

Designed to satisfy the most demanding concrete contractors, the Allen HDX Series of hydraulic-powered riding trowels are packed with the punch of high-horsepower diesel engines and are not only the most powerful riders in their class, they're also one of the most dependable. With ideal weight to horsepower ratios and hydraulic components, these riders ensure a peak performance every time.

HDX760

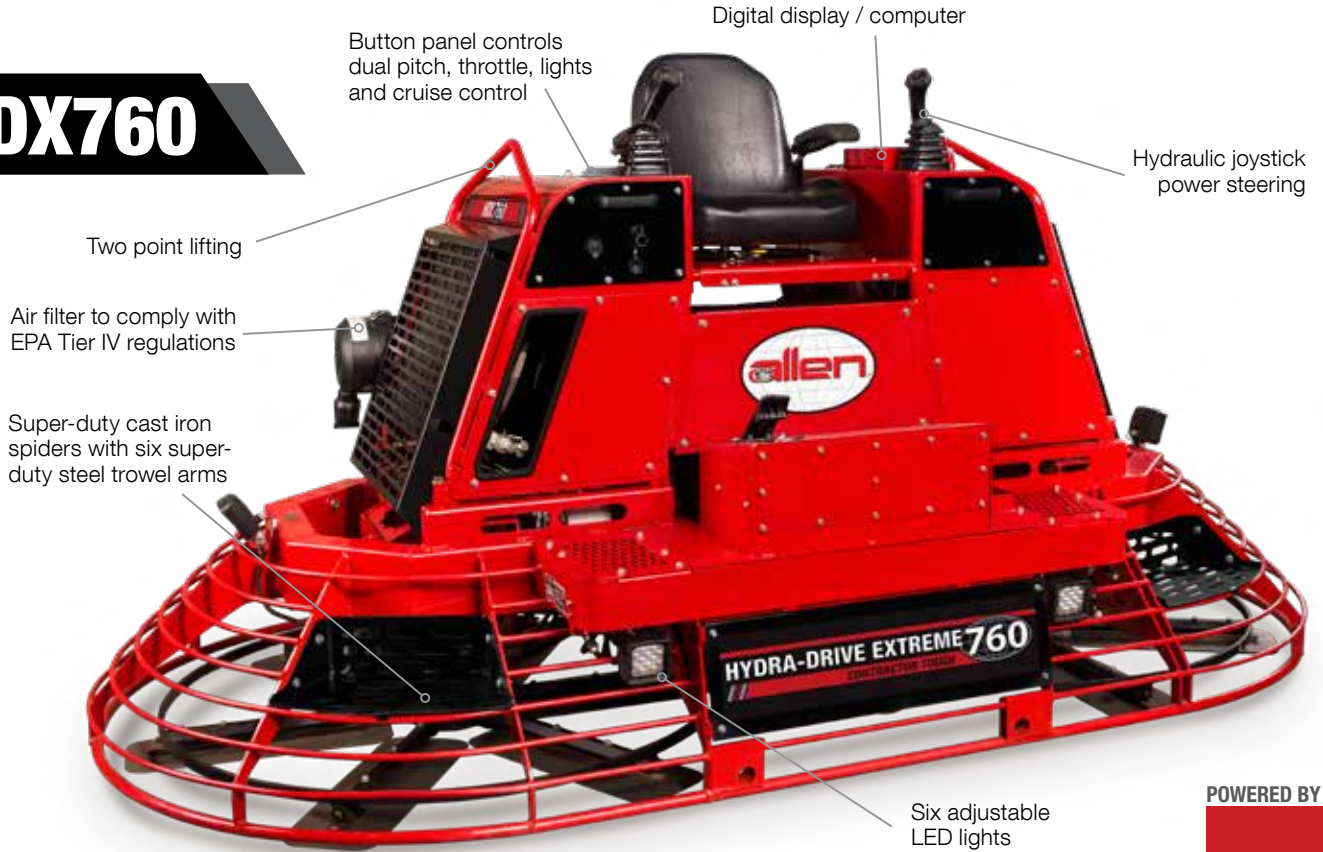

POWERED BY



The powerful 74 hp Hatz Tier IV Final engine will provide all the power you will need for any job size.



The digital display will allow you to see rpm, temperature, hours, and more in one convenient place.

HDX605

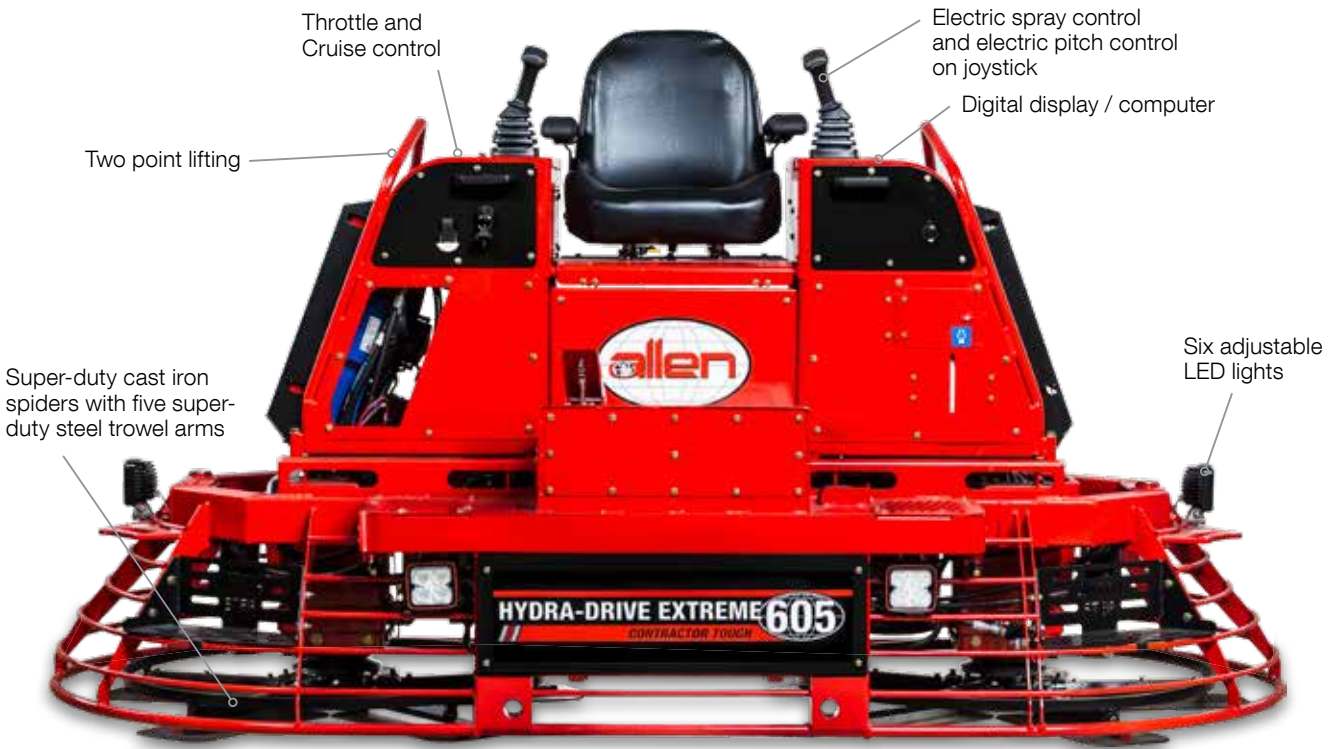

POWERED BY
Kubota



Digital read out shows accurate fuel levels, temperatures and more.



Reliable Kubota 57 hp gasoline engine provides excellent power. Lower cost alternative to T4F diesel engine machines.

DESCRIPTION	HDX605	HDX760
ENGINE	Kubota WG1605	Hatz 4H50TIC (T4F)
HORSEPOWER CLASS	57 hp (42.5 kW)	74 hp (55 kW)
FUEL TYPE	Gasoline	Diesel
PANNING PATH WIDTH	101.5 in (39.9 cm)	117.6 in (298.7 cm)
ROTORS (DIAMETER)	46 in (116.8 cm) 5-Bladed Spider	57.6 in (146.3 cm) 6-Bladed Spider
MAXIMUM ROTOR SPEED	160 rpm	145 rpm
STEERING CONTROL SYSTEM	Power	Power
FUEL CAPACITY	13 gal (49.2 L)	11 gal (41.6 L)
RETARDANT CAPACITY	6 gal (23 L)	6 gal (23 L)
WEIGHT	2,049 lb (929 kg)	2,687 lb (1,219 kg)
DIMENSIONS (L x W x H)	101.5 x 66 x 60 in (267.9 x 167.6 x 152.4 cm)	122.7 x 62.7 x 62 in (311.6 x 159.3 x 157.5 cm)



HIGH PERFORMANCE RIDERS

The High Performance series of riding trowels, feature twin gasoline engines. These machines are workhorses built for concrete professionals that delivers maximum horse power with electronic fuel injection. Utilizing torque converter clutches, they provide excellent low speed torque for low speed float panning and superior high rotor speed for finishing concrete.

HP205



POWERED BY
KOHLER

DESCRIPTION	HP205
ENGINE	2x - Kohler ECH980 (999cc) (EFI)
HORSEPOWER CLASS	37 hp (27.6 kW) per engine
FUEL TYPE	Air-Cooled Gasoline
PANNING PATH WIDTH	117.6 in (298.7 cm)
ROTORS (DIAMETER)	57.6 in (146.3 cm) 6-Bladed Spider
MAXIMUM ROTOR SPEED	180 rpm
STEERING CONTROL SYSTEM	Power
FUEL CAPACITY	12 gal (46 L)
RETARDANT CAPACITY	6 gal (23 L)
WEIGHT	2,169 lb (983 kg)
DIMENSIONS (L x W x H)	123.7 x 63.2 x 62.1 (314.2 x 160.5 x 157.7 cm)



To ensure maximum energy transfer between the engine and the rotors, we equipped the HP205 with our largest gearbox (XHD).

MECHANICAL SUPER PRO RIDERS

Featuring your choice of joystick power or manual lever steering and the power of gasoline engines, the Mechanical-Drive Super Pro (MSP) Series is our most popular series of riders with larger contractors. These riding trowels are powerful and responsive due their weight-to-horsepower ratio.



Four lights in front and back

Independent manual pitch control

Hydraulic joy stick power steering

MSP455

Light switch, 12 volt charger, and hour meter in one convenient location

Detachable front access panels

Raised operator platform

POWERED BY
KOHLER



DESCRIPTION

MSP455

ENGINE	Kohler CH1000 (999cc)
HORSEPOWER CLASS	37 hp (27.6 kW)
FUEL TYPE	Air-Cooled Gasoline
PANNING PATH WIDTH	97.5 in (248 cm)
ROTORS (DIAMETER)	46 in (117 cm) 5-Bladed Spider
MAXIMUM ROTOR SPEED	165 rpm
STEERING CONTROL SYSTEM	Power
FUEL CAPACITY	6 gal (23 L)
RETARDANT CAPACITY	6 gal (23 L)
WEIGHT	1,175 lb (533 kg)
DIMENSIONS (L x W x H)	101.5 x 50.5 x 59.5 in (254 x 128 x 151 cm)

MSP445



POWERED BY
KOHLER



The torque converter clutch ensures maximum control over machine speed.



Our super heavy-duty gearboxes have a 20:1 gear box ratio that provides superior rotor speeds.



DESCRIPTION

MSP445

ENGINE	Kohler CH1000 (999cc)
HORSEPOWER CLASS	37 hp (27.6 kW)
FUEL TYPE	Air-Cooled Gasoline
PANNING PATH WIDTH	97.5 in (248 cm)
ROTORS (DIAMETER)	46 in (117 cm) 5-Bladed Spider
MAXIMUM ROTOR SPEED	165 rpm
STEERING CONTROL SYSTEM	Manual
FUEL CAPACITY	6 gal (23 L)
RETARDANT CAPACITY	6 gal (23 L)
WEIGHT	1,052 lb (477 kg)
DIMENSIONS (L x W x H)	101.5 x 50.5 x 59.5 in (254 x 128 x 151 cm)

NZ Distributor

TRADESMART

MECHANICAL PRO RIDERS

The Mechanical-Drive Pro (MP) Series represents our entry-level riders complete with features found on our larger riders and the renowned durability of all Allen equipment. These riders—in three convenient sizes—are equipped with high-horsepower gasoline engines, heavy-duty drivetrains and packed in easy-to-service frames.



POWERED by
HONDA



Easy-to-access switches and 12 volt charging plug for phones or electronic devices.



Proven dependability and reliability from our standard-duty gearboxes.

DESCRIPTION	MP315
ENGINE	Honda GX690 (688 cc)
HORSEPOWER CLASS	22.1 hp (16.5 kW)
FUEL TYPE	Air-Cooled Gasoline
PANNING PATH WIDTH	95 in (241 cm)
ROTORS (DIAMETER)	46 in (117 cm) 4-Bladed Spider
MAXIMUM ROTOR SPEED	145 RPM
STEERING CONTROL SYSTEM	Manual
FUEL CAPACITY	6 gal (23 L)
RETARDANT CAPACITY	6 gal (23 L)
WEIGHT	830 lb (376 kg)
DIMENSIONS (L x W x H)	98 x 50 x 53 in (249 x 127 x 135 cm)

MP245

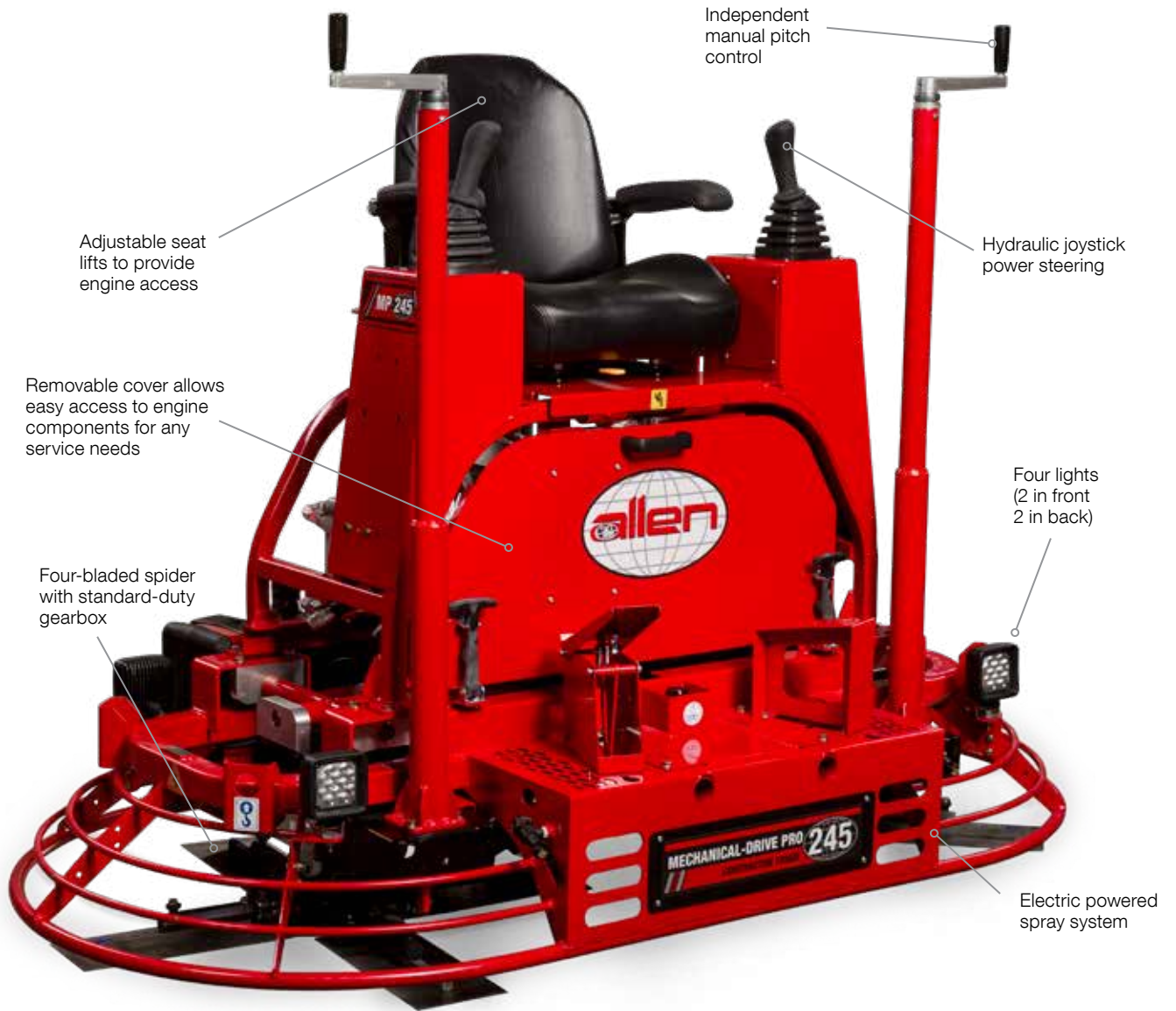

Adjustable seat lifts to provide engine access

Removable cover allows easy access to engine components for any service needs

Four-bladed spider with standard-duty gearbox

Independent manual pitch control

Hydraulic joystick power steering

Four lights (2 in front 2 in back)

Electric powered spray system

POWERED by HONDA™



Our MP245 features hydraulic joy stick steering for your convenience.



Powerful 22 hp air-cooled, gasoline Honda engine provides great power for all of your finishing needs.

MP235



The patented MP235 Edger, with its unique rotating guard rings allows you to run along the edges of walls, around columns and pipes—for a close, clean finish every time. This exclusive Allen Rider allows you to edge within 5/16" of the edge of a wall, eliminating the need to hand finish those areas. This patented trowel features similar specifications as our MP215, along with a stretched frame for improved productivity and operator comfort.



DESCRIPTION	MP215	MP235	MP245
ENGINE	Honda GX690 (688 cc)	Honda GX690 (688 cc)	Honda GX690 (688 cc)
HORSEPOWER CLASS	22.1 hp (16.5 kW)	22.1 hp (16.5 kW)	22.1 hp (16.5 kW)
FUEL TYPE	Air-Cooled Gasoline	Air-Cooled Gasoline	Air-Cooled Gasoline
PANNING PATH WIDTH	74 in (188 cm)	85 in (216 cm)	74 in (188 cm)
ROTORS (DIAMETER)	36 in (91.4 cm) 4-Bladed Spider	36 in (91.4 cm) 4-Bladed Spider	36 in (91.4 cm) 4-Bladed Spider
MAXIMUM ROTOR SPEED	145 rpm	145 rpm	165 rpm
STEERING CONTROL SYSTEM	Manual	Manual	Power
FUEL CAPACITY	6 gal (23 L)	6 gal (23 L)	6 gal (23 L)
RETARDANT CAPACITY	6 gal (23 L)	6 gal (23 L)	6 gal (23 L)
WEIGHT	735 lb (333 kg)	783 lb (355 kg)	830 lb (376.5 kg)
DIMENSIONS (L x W x H)	78 x 41 x 53 in (198 x 104 x 135 cm)	86 x 39 x 53 in (218 x 99 x 135 cm)	78 x 41 x 57.5 in (198 x 104 x 146 cm)

STEEL FLOAT PANS

Allen Engineering pioneered the use of floating discs (or pans) on riding trowels in 1989 and Allen® Pans remain today the finisher's choice when high F_f Numbers are specified on a concrete floor. Allen's flat pan tolerances cut bumps and fill low spots in the concrete floor. Insist on Allen® Steel Pans for your Allen Riders and Walk-Behinds. Made to the same exacting tolerances as the trowels themselves, nothing finishes better.



Safety Catch Pan

Clip-On Pan

TWO TYPES OF PANS

Allen offers both Flat (0" to 1/8" dish) and Mild-Dished (1/4" to 3/8" dish) steel pans. This gives contractors even more pan choices from Allen.



MADE IN THE U.S.A.
FROM U.S. MADE
STEEL

TROWEL BLADES

Allen Engineering offers a complete line of finish blades, combination blades and clip-on float shoes for your walk-behind or ride-on power trowels. We use high quality steel or composite plastic with six high strength rivets to maximize blade life. For the flattest floors, trust only Allen Finishing Blades. And, Allen Blades fit most other brands of walkers and riders.

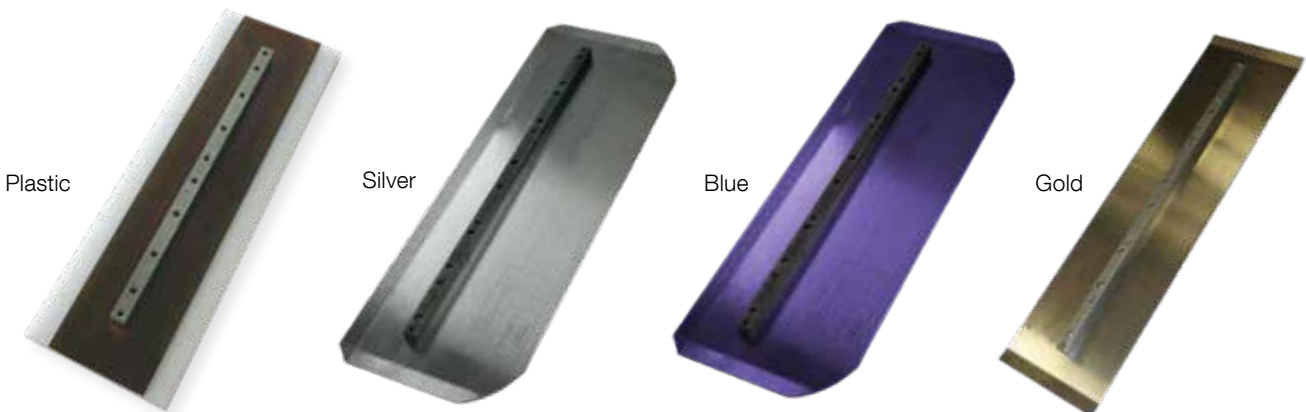

Plastic

Silver

Blue

Gold

POWER SPRAYERS

Our powerful, reliable and durable power sprayers are the preferred tool for applying release agents, water-based sealants and curing compounds on concrete construction sites. The continuous recirculating system ensures your material is always well mixed and ready to spray. Available in barrel, cart or tow models.



PS9910 with Optional tow cart (PSTCPT-3W)



PS9910 with Optional push cart (PSPCP-2)

POWERED by **HONDA**

DESCRIPTION	PS9910	PS7560XL
ENGINE	Honda GX160 (163 cc)	Honda GX120 (118 cc)
HORSEPOWER CLASS	5.5 hp (4.1 kW)	4 hp (3 kW)
MAXIMUM FLOW RATE	9.5 gpm	7.5 gpm
PUMP TYPE	Diaphragm	Roller Ball
HOSE TYPE	Hydraulic	3/8" Lock-On
HOSE LENGTH	50 ft (15.24 m)	50 ft (15.24 m)
SPRAYER TIP	Fan Tip 4020	Fan Tip 4020
MAXIMUM SOLID CONTENT	35%	30%
WEIGHT	134 lb (61 kg)	106 lb (48 kg)



TRIPLE ROLLER TUBE PAVERS

Allen Triple Roller Tube Pavers (TRTP) are specifically designed for paving large projects fast, accurately and efficiently. Powered by powerful engines, with easy-to-operate control systems, and with our precision engineered and level-tested roller tubes, you can be assured of producing the flattest paving job possible.

TRTP275

Gang vibration system for up to 24" (61cm) deep concrete consolidation

Gang vibration folds in for easier machine transport

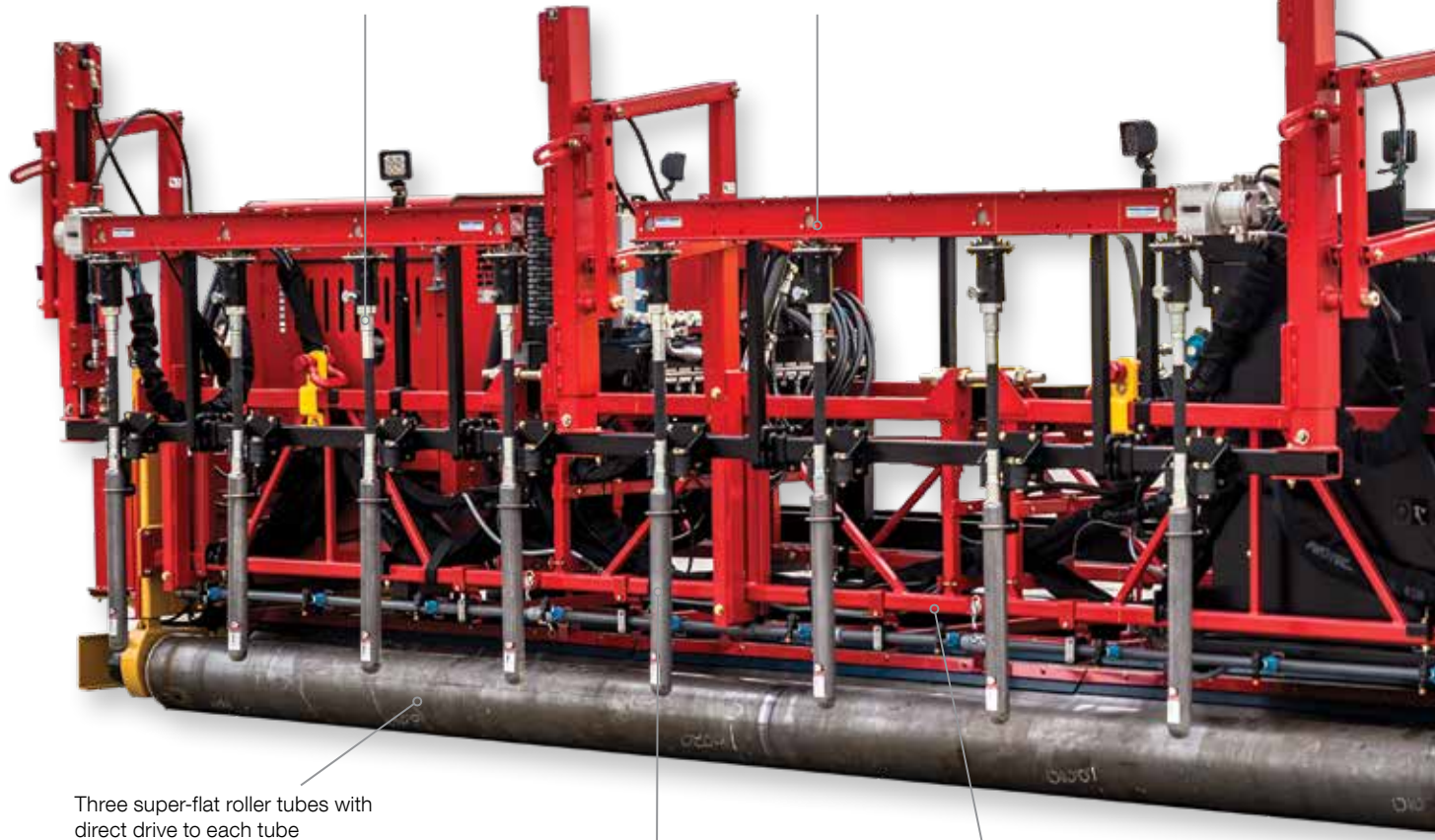



Three super-flat roller tubes with direct drive to each tube

Pendulum shaft driven vibrators can be adjusted from 0 – 11,000 vpm from operator console

Heavy-duty sectionalized truss system has an adjust-able frame section for frame deflection for longer machines

POWERED BY



DESCRIPTION	TRTP275 	TRTP255T4 	TRTP150B
ENGINE	Hatz 4H50TIC (T4F)	Hatz 4H50TIC (T4F)	Kohler CH1000 (999cc)
HORSEPOWER CLASS	74 hp (55.2 kW)	49.5 hp (36.4 kW)	37 hp (27.6 kW)
FUEL TYPE	Liquid-Cooled Diesel	Diesel	Air-Cooled Gasoline
WIDTHS AVAILABLE (2 FT INCREMENTS)	12 - 34 ft (3.6 - 10.4 m)	12 - 34 ft (3.6 - 10.4 m)	12 - 32 ft (3.6 - 9.7 m)
WEIGHT AT 22 FT	8,700 lb (3,946 kg)	5,570 lb (2,526 kg)	2,790 (1,266 kg)
ROLLER TUBE DIAMETER	10 in (25.5 cm)	10 in (25.5 cm)	6.625 in (16.8 cm)
TUBE WEIGHT PER FT	27 lb (12 kg)	27 lb (12 kg)	19 lb (9 kg)
HYDRAULIC OIL RESERVOIR	60 gal (227 L)	25 gal (95 L)	13.5 gal (41 L)
HYDRAULIC SPRAY SYSTEM	Standard	Standard	Standard
HYDRAULIC STEERING LEG	Standard	Standard	Standard

NZ Distributor

TRADESMART



Operator console positioned inside of main frame



TRTP275



TRTP150B



TRTP255T4

STEEL EDGE FORMS AND ACCESSORIES

Allen offers a complete line of steel edge forms, including straight forms, radius forms and heavy-duty paving forms.



BRIDGE DECK FINISHERS

Our bridge deck finishers are becoming the choice for high-volume bridge and pavement pours. Three models are available with many accessories, so there's an Allen finisher for every bridge and pavement pour.



BDF4836B



BDF4836T4

DESCRIPTION	BDF4836B	BDF6036B	BDF6048B
OPERATOR'S CONSOLE ENGINE	Kohler CH740 (725 cc)	Kohler CH740 (725 cc)	Kohler CH740 (725 cc)
HORSEPOWER CLASS	23.5 hp (17.5 kW)	23.5 hp (17.5 kW)	23.5 hp (17.5 kW)
FUEL TYPE	Air Cooled Gasoline	Air Cooled Gasoline	Air Cooled Gasoline
PAVING CARRIAGE ENGINE	Kohler CH740 (725 cc)	Kohler CH740 (725 cc)	Kohler CH740 (725 cc)
HORSEPOWER CLASS	23.5 hp (17.5 kW)	23.5 hp (17.5 kW)	23.5 hp (17.5 kW)
FUEL TYPE	Air Cooled Gasoline	Air Cooled Gasoline	Air Cooled Gasoline
MAXIMUM WIDTH ***	90 ft (27.4 m)	90 ft (27.4 m)	120 ft (36.5 m)
PAVING ROLLERS	Dual 48 in (121.9 cm)	Dual 60 in (152.3 cm)	Dual 60 in (152.3 cm)
AUGERS	Dual 8 in (203 mm) Adjustable	Dual 8 in (203 mm) Adjustable	Dual 8 in (203 mm) Adjustable
SECTION WIDTHS AVAILABLE	3, 4, 6, 12 and 15 ft (1, 1.2, 1.8, 3.7 & 4.6 m)	3, 4, 6, 12 and 15 ft (1, 1.2, 1.8, 3.7 & 4.6 m)	3, 4, 6, 12 and 15 ft (1, 1.2, 1.8, 3.7 & 4.6 m)
BOGIES-DRIVER*	Two Cupped Wheels - 36 in (91.4 cm)	Two Cupped Wheels - 36 in (91.4 cm)	Two Cupped Wheels - 48 in (121.9 cm)
BOGIES-IDLE*	Two Cupped Wheels - 36 in (91.4 cm)	Two Cupped Wheels - 36 in (91.4 cm)	Two Cupped Wheels - 48 in (121.9 cm)
JACKS HEIGHT ADJUSTMENT	44 in (111.8 cm) Vertical Adjustment	44 in (111.8 cm) Vertical Adjustment	44 in (15.2 to 111.8 cm) Vertical Adjustment
JACKS (WITH SOLID LEG PLATES) **	Manual - 4 in (10.1 cm) or 6 in (15.2 cm) Powered Optional - 6 in (15.2 cm)	Manual - 4 in (10.1 cm) or 6 in (15.2 cm) Powered Optional - 6 in (15.2 cm)	Powered - 6 in (15.2 cm)

* Other Wheel options available

** Pivot leg plates optional

*** Consult factory for wider widths

Consult factory for additional specs & options



POWERED BY
KOHLER

BDF6036B



BDF6048B

OPTIONS & ACCESSORIES

Our Bridge Deck Finishers are fully customizable and can be configured to meet most any bridge deck or paving project.



End Jack Swing Outs
(Optional)



Power Crown
(Optional)



Power Up/Down Jacks
(Optional on 4836B and 6036B. Standard on 6048B)



Pipe Rails & Chairs
(Optional)

WORK BRIDGES

Allen Work Bridges can be customized for every application. These work bridges are ideal for joint work, applying curing compounds, bull-floating, applying textures or whenever bridging is required. The Allen Work Bridge is an economical workhorse on any job site.



WB1224



WHEEL KIT

Rubber tires can be mounted in 360° swivel bearings with four position directional locks and individual brakes to allow work bridges to operate without the need for rails. (Available for all models)



PAVING ADJUSTABLE END BRACKETS

28" (71 cm) height from top of deck to slab (vertically adjustable end frames from 16" - 36" (40.6 - 91.4 cm) from the top of deck to slab optional).



WB1824



CUSTOM CONFIGURATIONS ALSO AVAILABLE

If you need something taller, wider, etc give us a call and we may be able to develop a custom solution like this 160' (48 m) WB4834.



POWERED BRIDGES

9 hp Honda engines power hydraulic drive bogies to help alleviate the need for extra man power to push work bridges.



MANUAL SCREW JACKS

6" (15.2 cm) diameter jacks allow for easy raising or lowering of work bridge ends.

DESCRIPTION	WB1224	WB1824	WB2434
FRAME DIMENSIONS (D x W)	12 x 24 in (30.5 x 61 cm)	18 x 24 in (45 x 61 cm)	24 x 34 in (61 x 86.3)
MAX WORK BRIDGE LENGTH	65 ft (20 m)	105 ft (32 m)	120 ft (36.5 m)
MAX WEIGHT LIMIT	250 lb (113 kg) at 65' (20 m)	1,000 lb (453.5 kg) at 105' (32 m)	1,000 lb (453.5 kg) at 120' (36.5 m)
AVAILABLE SECTIONS	2 ft (0.61 m) 5 ft (1.52 m) 7 ft (2.28 m)	3 ft (.91 m) 6 ft (1.83 m) 12 ft (3.66 m)	3 ft (.91 m) 6 ft (1.83 m) 12 ft (3.66 m)
TELESCOPIC SECTIONS	N/A	15 - 25 ft. (4.57 - 7.62 m)	15 - 25 ft. (4.57 - 7.62 m)

DESCRIPTION	POWERED KIT AVAILABLE FOR WB1824 / WB2434
ENGINE	Honda GX270 (270 cc)
HORSEPOWER CLASS	9 hp (6.7 kW)
FUEL TYPE	Gasoline

VERSATILE LIGHT PAVERS

The Versatile Light Paver can be used to strike off concrete between multiple obstacles in tight constricted work areas. These pavers increase profitability by saving time and labor, and they are versatile enough to adapt to the specifications of many projects. They are great for Light Rail Transit Bridges & Stations, Switch-Back Pedestrian Walkways, Light Bridge Deck Surfaces & Roadway Transit Lines.



POLYESTER SLIP FORM PAVERS

APSFP Polyester Pavers are the perfect solution for placing polyester overlays. These machines are compact in size, and they come equipped with a dolly jack system that saves time getting the machine on and off the job. These machines can be customized to meet the demands of any job.



Hydraulic lift cylinders lift up to 30" (76.2 cm) to allow easy access to bottom of paver for cleaning and maintenance

Hydraulic pump system with control valving

Safety light

Central Operator Controls



Dolly jack system

Rub skirt helps contain the polyester concrete

Conveyor belt placer with splash guard

Crawler Tracks

Grade Control System



NZ Distributor:
TRADESMART
Ph. 09 283 9658
info@tradesmart.co.nz
www.tradesmart.co.nz

allen
ENGINEERING
CORPORATION