

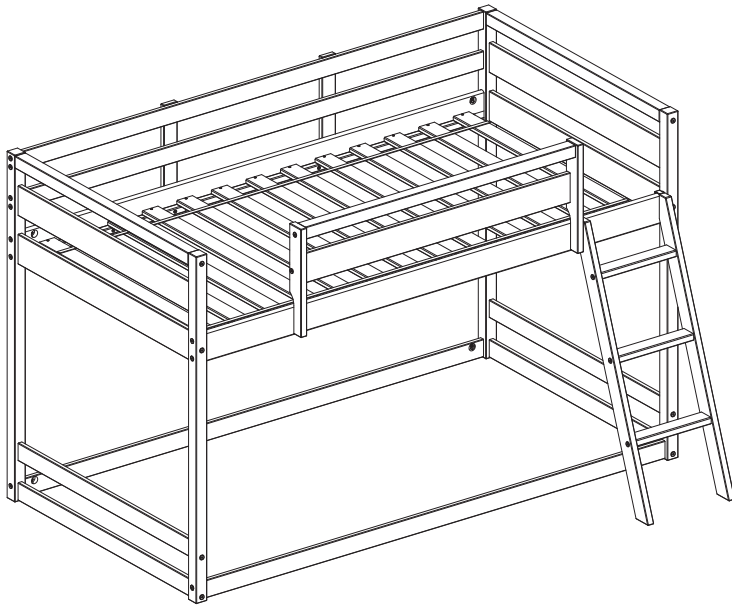

Quadra Twin Bunk Bed

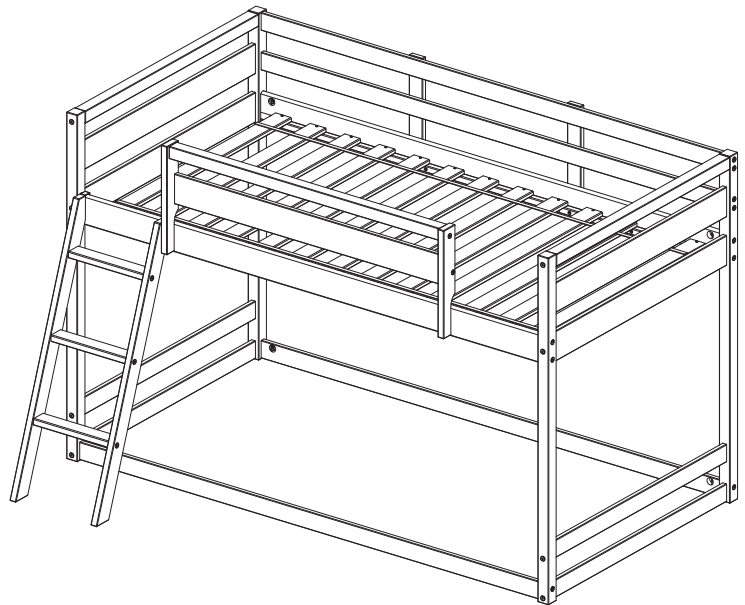

Options



**READ ALL INSTRUCTIONS BEFORE ASSEMBLING BUNK BED.
KEEP INSTRUCTIONS FOR FUTURE USE.
THE ASSEMBLY OF THIS PRODUCT REQUIRES TWO ADULTS.**



WARNING:

ADULT ASSEMBLY REQUIRED.

Product must be assembled by an adult before use.

After assembly has been completed, all remaining materials and packaging are to be recycled according to the regulations in force and kept out of children's reach. Components left after the assembly are not intended for play.

Failure to follow these warnings and the assembly instructions could result in serious injury or death.

Bunk bed is intended for home use, not to be used in public institutions. (hospitals, daycares, etc.)



WARNING:

California Proposition 65

This product can expose you to chemicals including wood dust, which is known to the State of California to cause cancer and birth defects or other reproductive harm. For more information, go to www.p65warnings.ca.gov.



WARNING:

SIZE OF MATTRESS AND FOUNDATION

This bed is designed to use a twin mattress (37 $\frac{1}{2}$ " x 38 $\frac{1}{2}$ " x 74-75"). Mattress not included. A wood slat set is provided for the top bunk by the manufacturer.

The total thickness of the mattress and support must not exceed 7 inches.

NOTE: There MUST be at least 5 inches from top surface of mattress to top edge of guardrails.



WARNING:

To help prevent serious or fatal injuries from entrapment or falls:

- **STRANGULATION HAZARD** - Never attach or hang items to any part of the bed that are not designed for use with the bed; for example, but not limited to hooks, belts, strings and jump ropes.
- Follow the information on warning labels on bed and carton. **DO NOT REMOVE LABELS FROM BED.**
- Always use the recommended size of mattress or mattress support, or both, to help prevent the likelihood of entrapment or falls.
- Ensure thickness of mattress and foundation combined does not exceed 7 inches and that the mattress surface is at least 5 inches below upper edge of guardrails.
- Periodically check and ensure that the guardrail, ladder and other components are in their proper position free from damage, and that all connectors are tight.
- Do not use substitute parts. Contact the distributor for replacement parts.
- Never allow a child under 6 years on upper bunk.
- Prohibit more than one person on upper bunk.
- The use of a night light may provide added safety for child on upper bunk.
- Prohibit horseplay on or under beds and prohibit jumping on or from bed.
- Always use ladder for entering or leaving upper bunk.
- If the bunk bed will be placed next to a wall, the guardrail that runs the full length of the bed should be placed against the wall to prevent entrapment between the bed and the wall.
- Always use guardrails on both long sides of the upper bunk.
- The use of water or sleep flotation mattress is prohibited.
- Keep these instructions for future reference.

FOR MISSING PARTS OR HARDWARE:

DO NOT CONTACT THE STORE WHERE YOU MADE YOUR PURCHASE. Please contact the manufacturer directly at customercare@pkolino.com or 888-403-8992. For customer service cases involving hardware please provide the part number.

DO NOT TIGHTEN SCREWS UNTIL COMPLETELY ASSEMBLED.

P'kolino products meet or exceed US, EU, and Canadian safety standards. REG. NO. PA-27620 (CN)

P'kolino (pee-ko-lee-no) © 2023 P'kolino, LLC. All Rights Reserved. All New Materials: Pine Wood. FSC certified. Non toxic and VOC free finish. Made in Brazil.

Questions or comments? Please email: customercare@pkolino.com Or write to: P'kolino Studio • 7300 NW 35th Ave • Miami, FL 33147, USA. October / 2023

This Box Contains:

Bunk Bed Parts:

**WARNING LABEL
DO NOT REMOVE !**

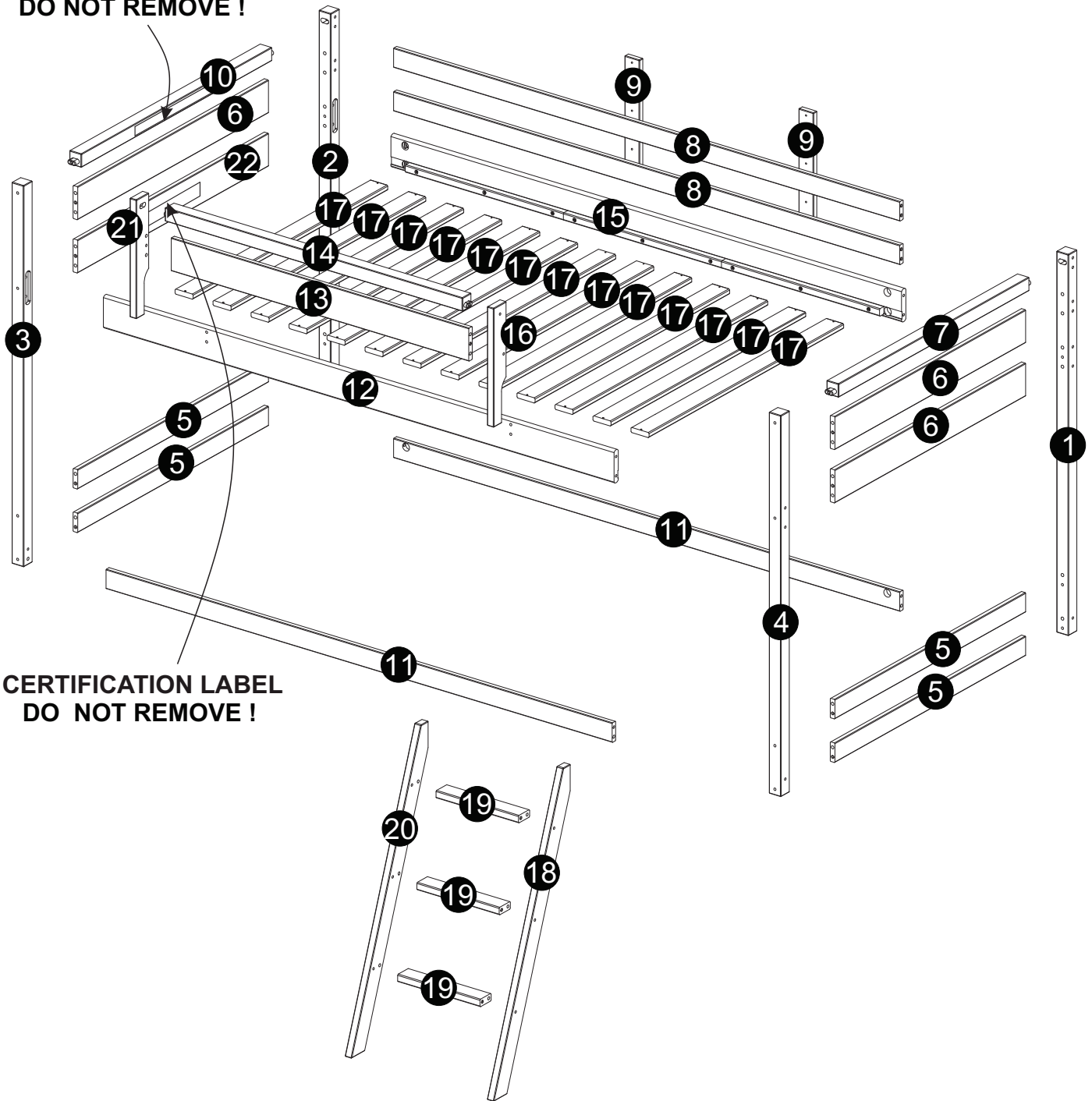

**CERTIFICATION LABEL
DO NOT REMOVE !**

Tools required

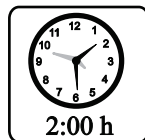
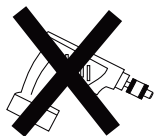
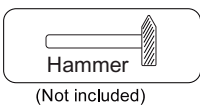
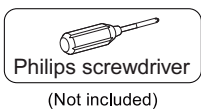

You will need a Phillips head screwdriver and a hammer

P'kolino products meet or exceed US, EU, and Canadian safety standards. REG. NO. PA-27620 (CN)

P'kolino (pee-ko-lee-no) © 2023 P'kolino, LLC. All Rights Reserved. All New Materials: Pine Wood. FSC certified. Non toxic and VOC free finish. Made in Brazil.

Questions or comments? Please email: customercare@pkolino.com Or write to: P'kolino Studio • 7300 NW 35th Ave • Miami, FL 33147, USA. October / 2023

Identify the size and type of hardware using the illustration below:

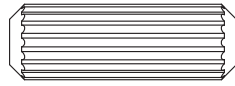

38 - Wooden dowels
1 3/16" (10 x 30mm) (A)

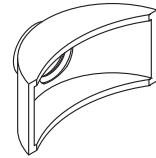

12 - 1/4 Half Moon Nut (G)

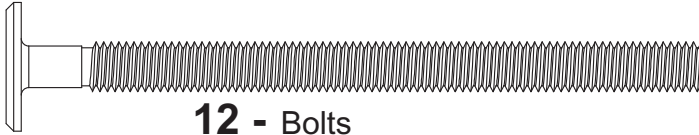
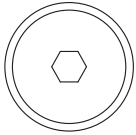

12 - Bolts
3 1/2" (1/4" x 90mm) (B)

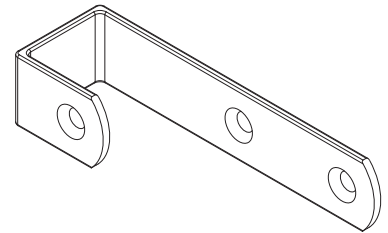

02 - Hook Ladder (H)

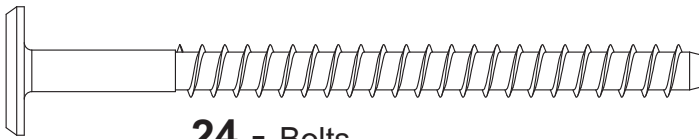
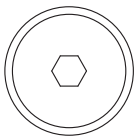

24 - Bolts
3 1/2" (7 x 90mm) (C)

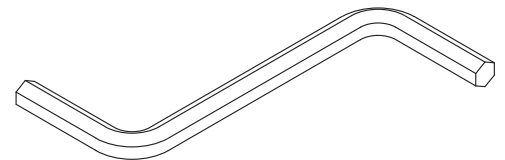

01 - Allen wrench (I)

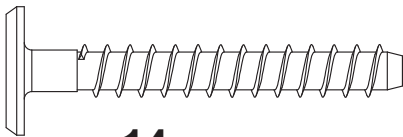
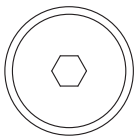

14 - Bolts
2" (7 x 50mm) (D)

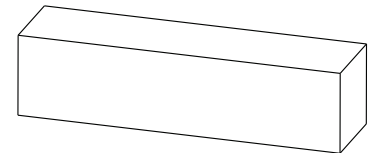

02 - Spacer (75 mm) (J)

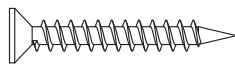

34 - Screws
1 3/16" (4 x 30mm) (E)

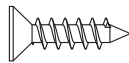

06 - Screws
5/8" (4 x 16mm) (F)

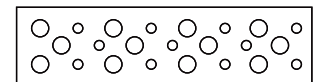

02 - Protector (K)

FOR MISSING PARTS OR HARDWARE:

DO NOT CONTACT THE STORE WHERE YOU MADE YOUR PURCHASE.

Please contact the manufacturer directly at customercare@pkolino.com or 888-403-8992.

For customer service cases involving hardware please provide the part number.

Assembly Instructions

THE USE OF POWER TOOLS IS NOT RECOMMENDED BECAUSE THEY CAN DAMAGE HARDWARE AND/OR SPLIT THE WOOD.

Step 1

Headboard/Footboard

Insert 24 wooden dowels (A) into the holes on to parts 5, 6, and 22 as shown in the diagram.

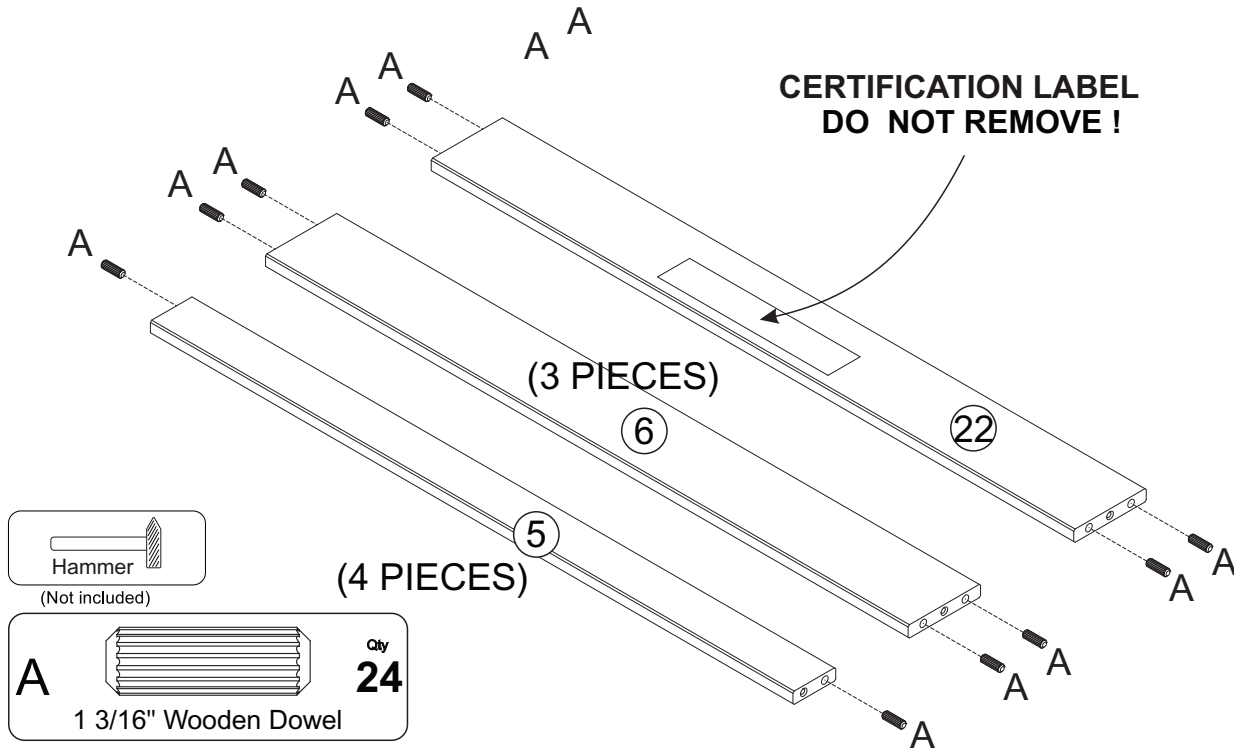

Step 2

Headboard/Footboard

Attach parts 5, 6, 10 and 22 on to part 3 with 4 bolts (C), using 1 Allen wrench (I).

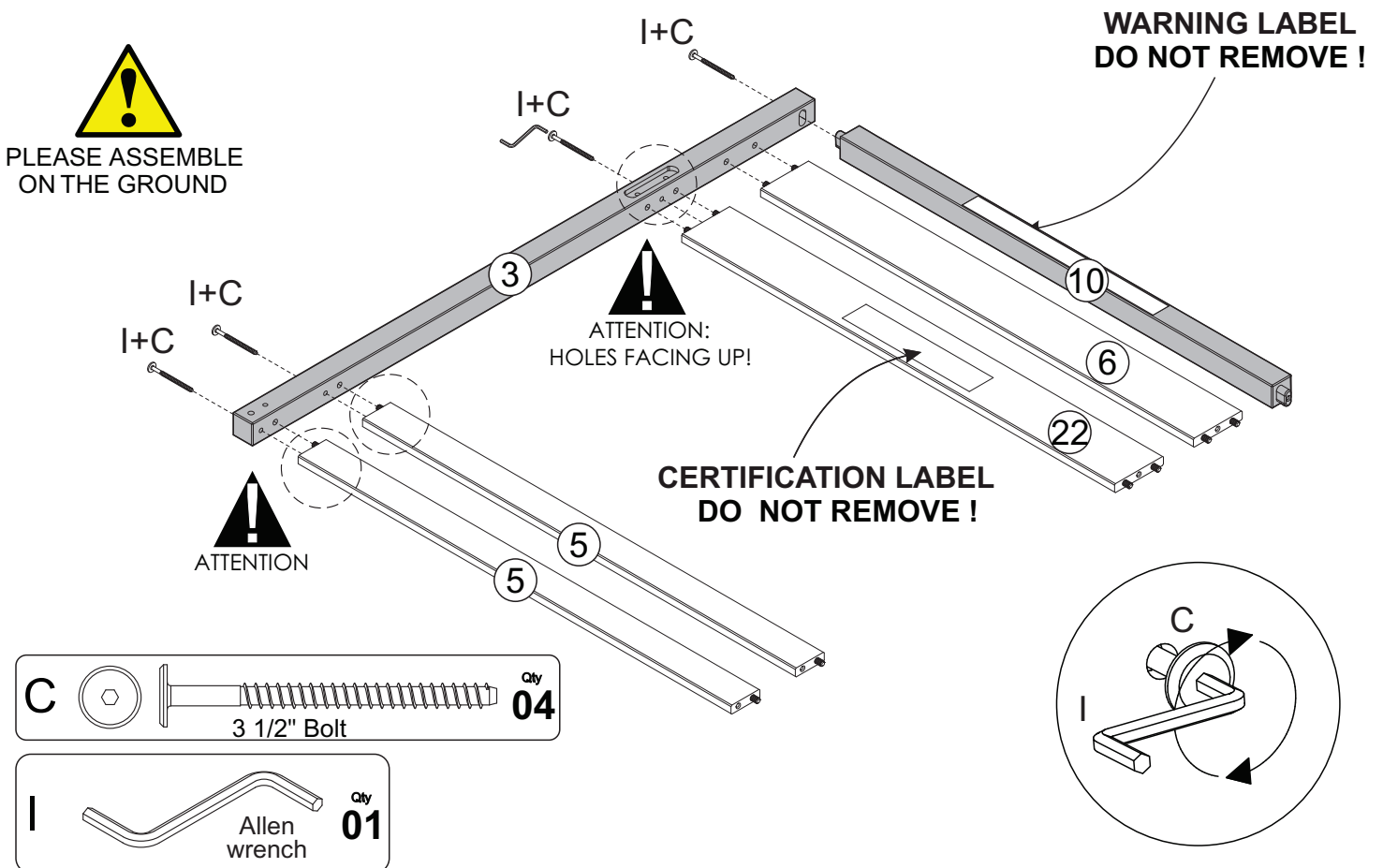

Assembly Instructions

Step 3

Headboard/Footboard

Attach parts 5, 6, 10 and 22 on to part 2 with 4 bolts (C), using 1 Allen wrench (I).



PLEASE ASSEMBLE
ON THE GROUND

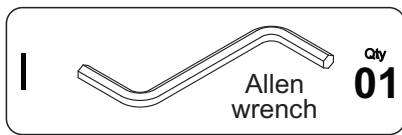
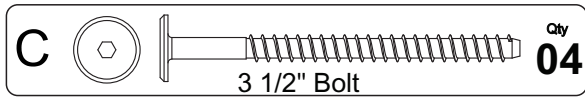
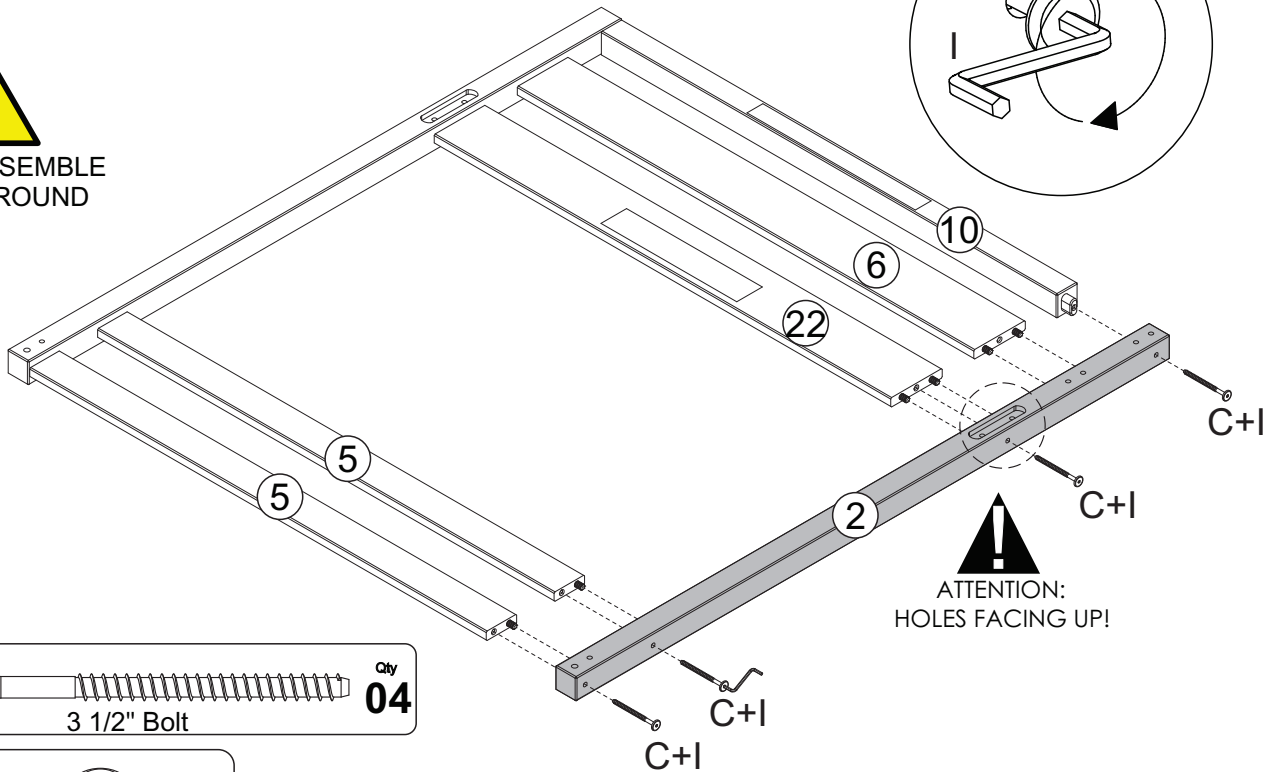

Step 4

Headboard/Footboard

Attach parts 5, 6 and 7 on to part 1 with 4 bolts (C), using 1 Allen wrench (I).



PLEASE ASSEMBLE
ON THE GROUND

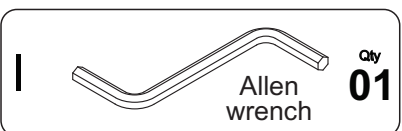
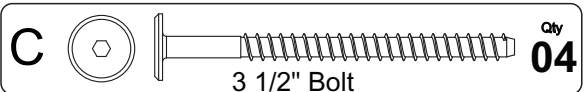
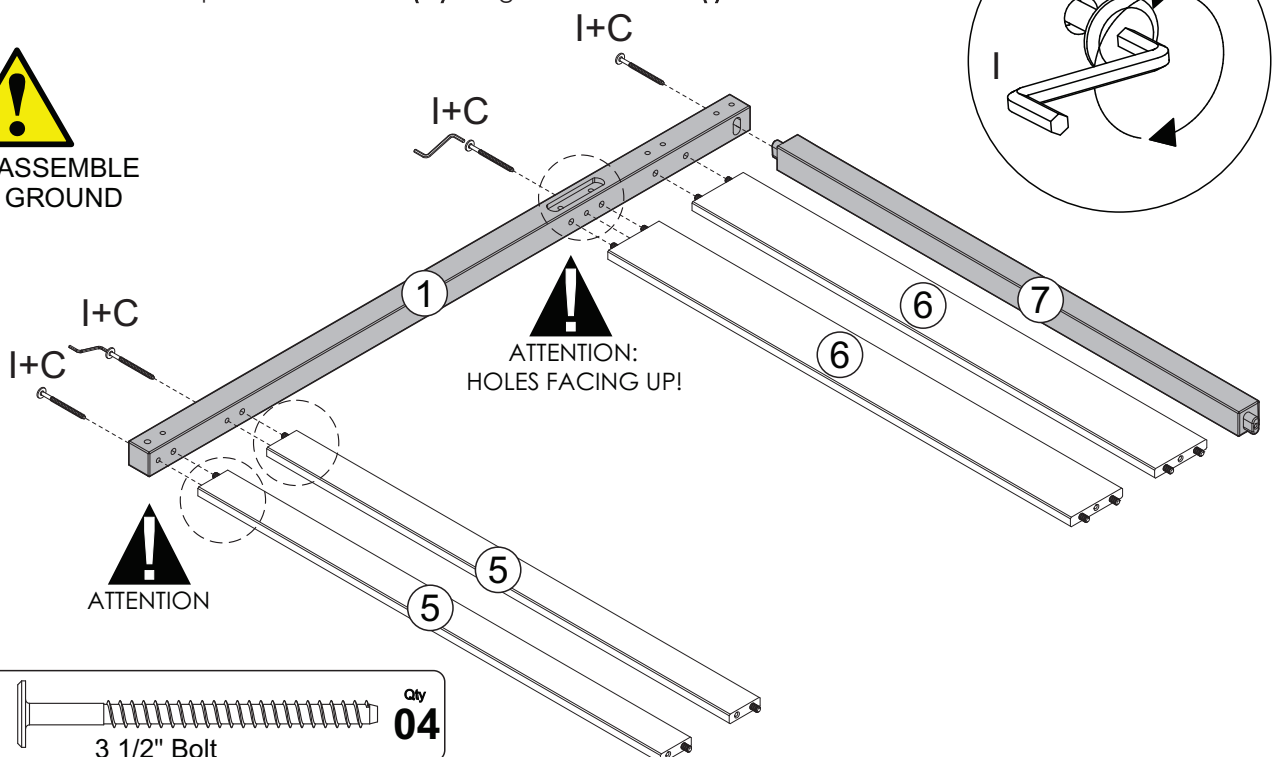

Assembly Instructions

Step 5

Headboard/Footboard

Attach parts 5, 6 and 7 on to part 4 with 4 bolts (C), using 1 Allen wrench (I).



PLEASE ASSEMBLE
ON THE GROUND

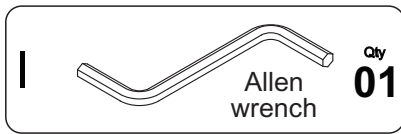
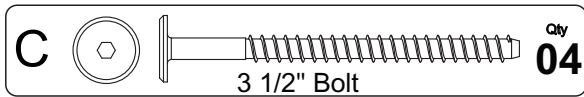
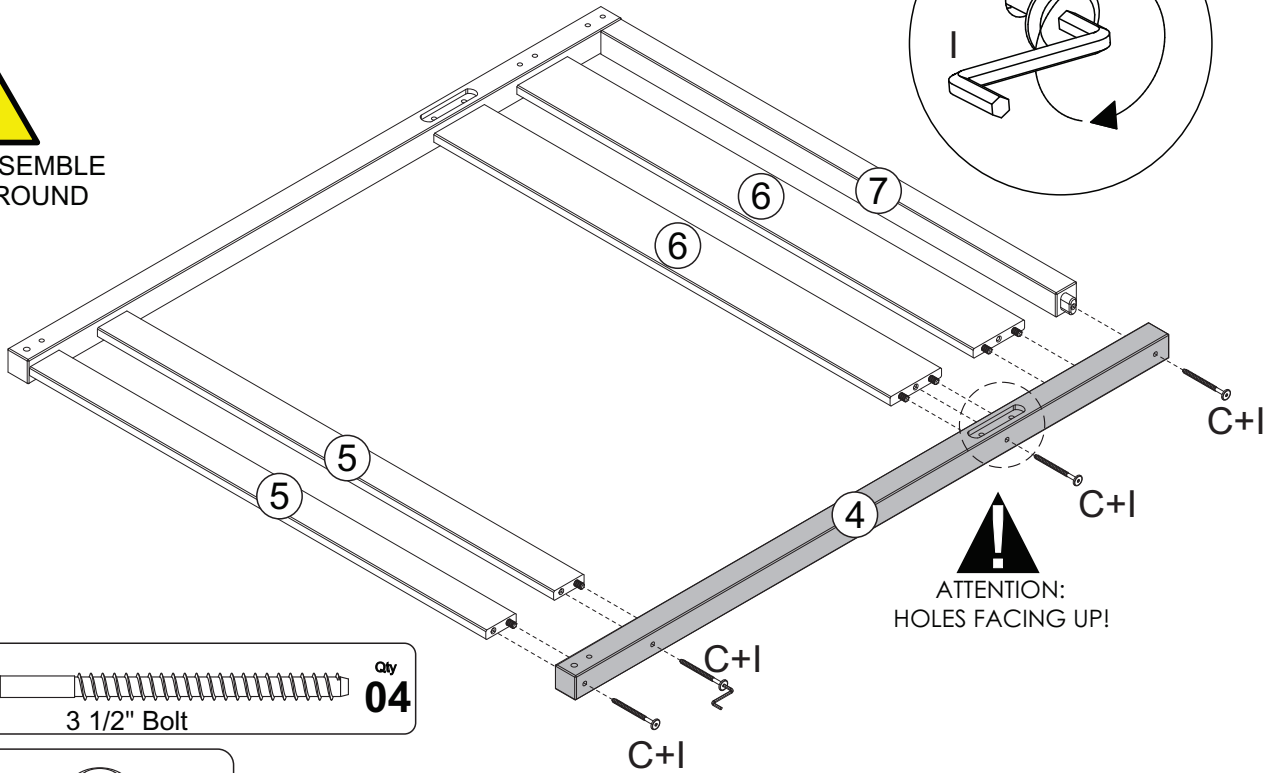
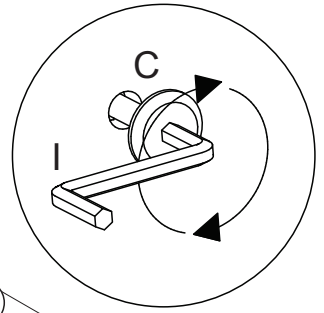

Step 6

Bottom Rails

Insert 4 wooden dowels (A) into the holes on to parts 11, as shown in the diagram.

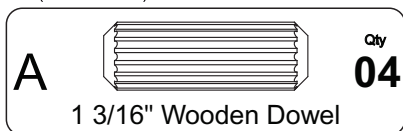
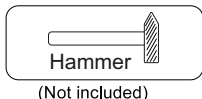
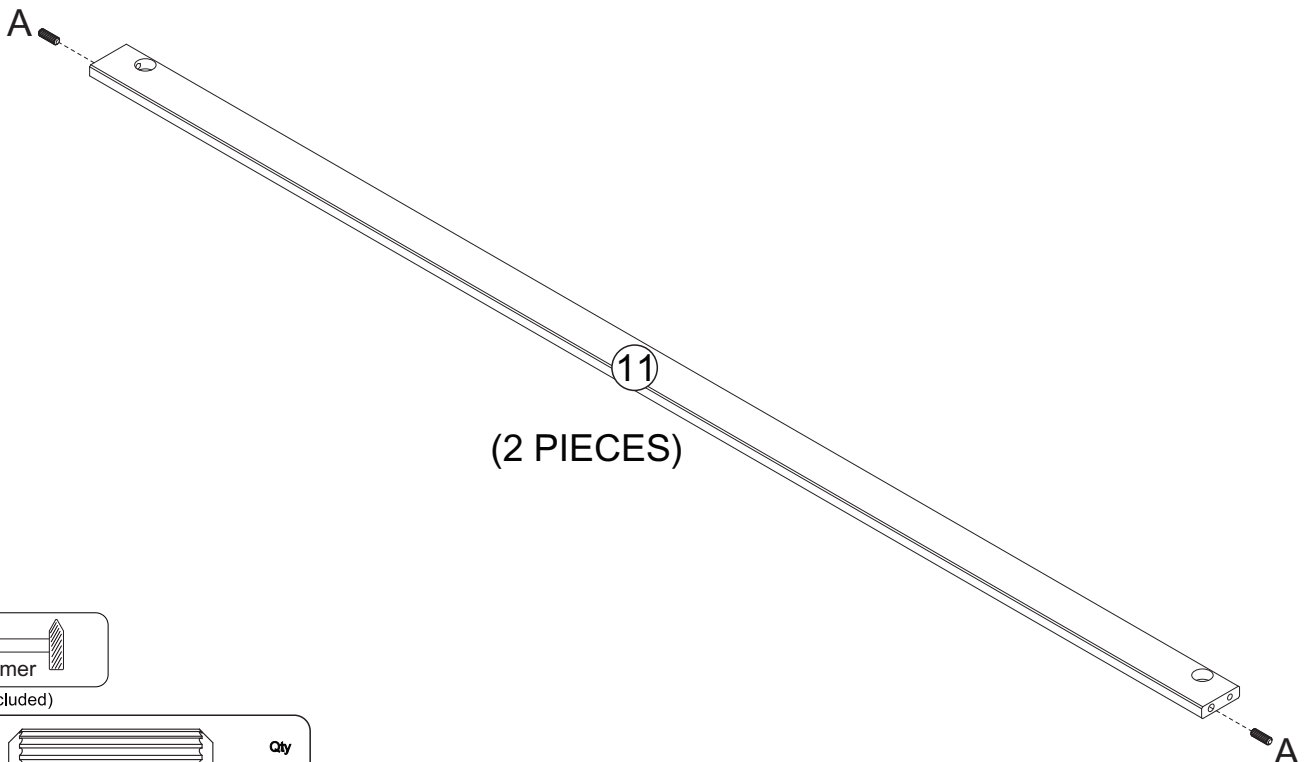

Assembly Instructions

Step 7

Bottom Rails

Attach part 11 on to Headboard with 1 bolt (B) and 1 half moon (G), using 1 Allen wrench (I).

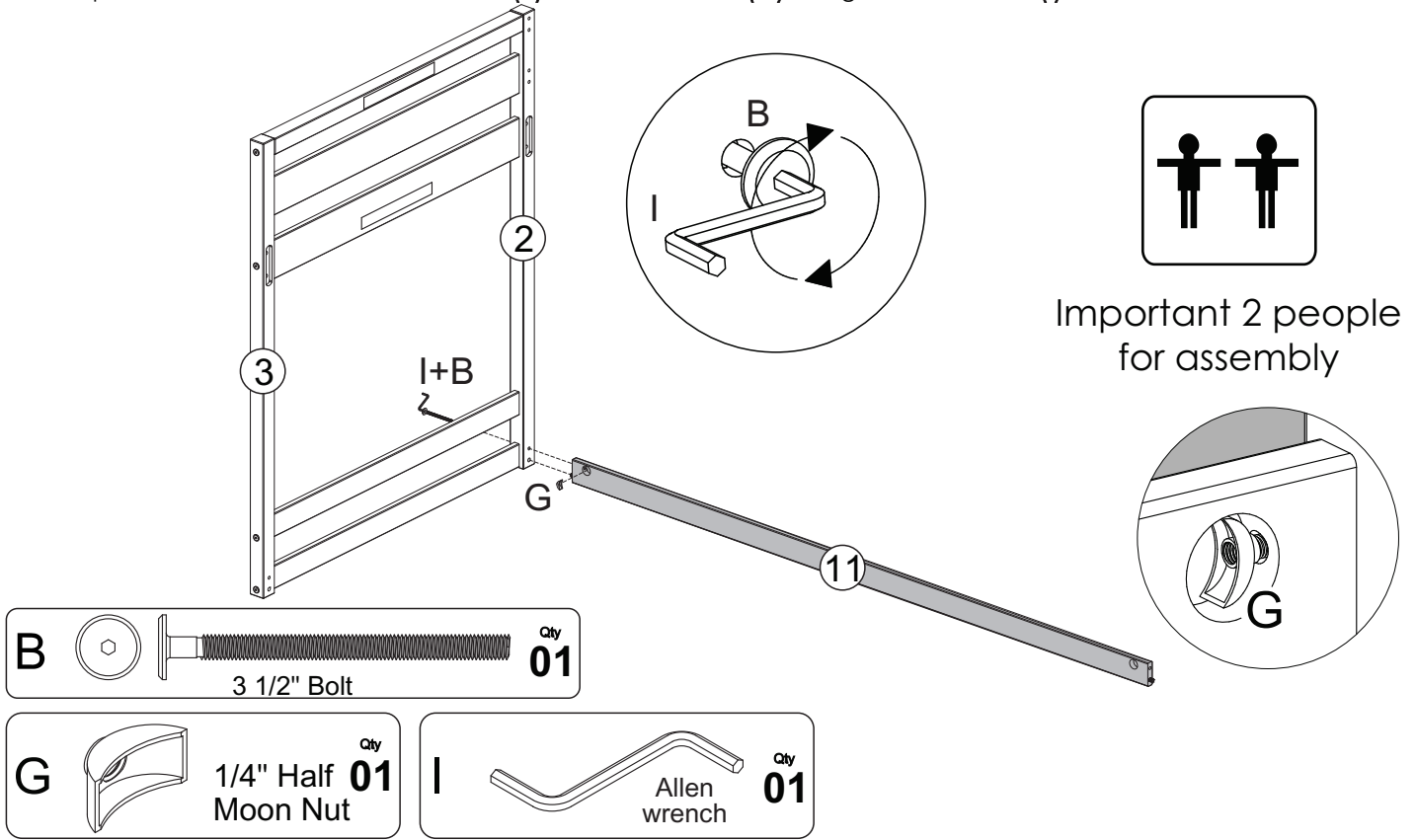

Step 8

Footboard

Attach Footboard on the part 11 with 1 bolt (B), 1 Half moons (G), using 1 Allen wrench (I).

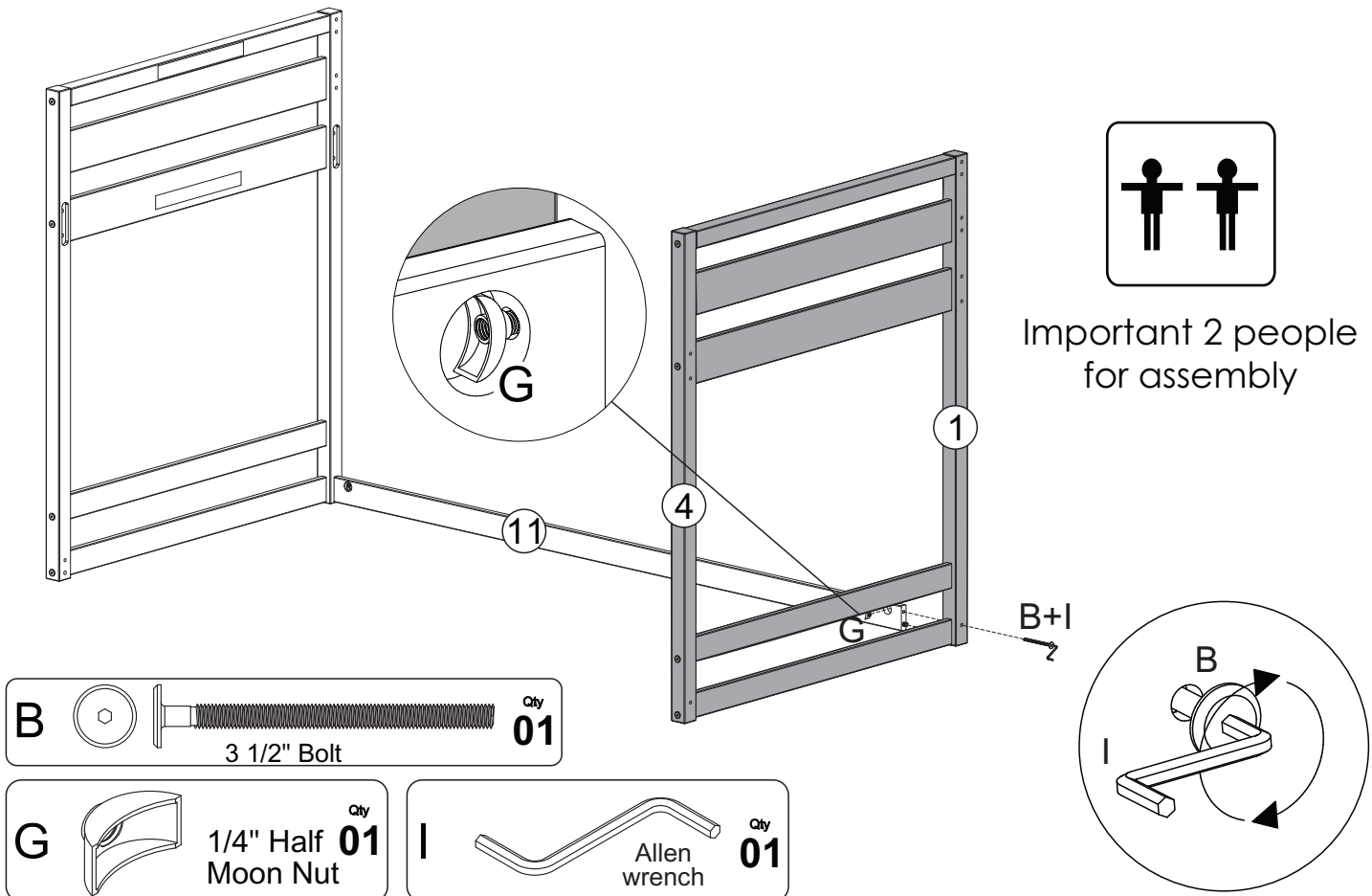

Assembly Instructions

Step 9

Siderails

Attach part 15 on the Headboard and Footboard with 4 bolts (B), 4 Half Moons (G), using 1 Allen wrench (I).

ATTENTION
BACK SIDE RAILS DOES NOT HAVE HOLES

GENTLY MOVE THE HEADBOARD AND FOOTBOARD TO FIT THE BACKSIDE RAIL

INSERT AND ATTACH BOLTS (B+G), BUT DO NOT TIGHTEN UNTIL STEP #13

B 3 1/2" Bolt Qty **04**

G 1/4" Half Moon Nut Qty **04**

I Allen wrench Qty **01**

Important 2 people for assembly

Step 10

Back Guardrails

Attach part 8 on the Headboard and Footboard with 4 bolts (C), using 1 Allen wrench (I).

GENTLY MOVE THE HEADBOARD AND FOOTBOARD TO FIT THE GUARDRAIL

INSERT AND ATTACH BOLTS (C), BUT DO NOT TIGHTEN UNTIL STEP #13

C 3 1/2" Bolt Qty **04**

I Allen wrench Qty **01**

Important 2 people for assembly

Assembly Instructions

Step 11

Back Guardrails

Attach part 8 on the Headboard and Footboard with 4 bolts (C), using 1 Allen wrench (I).

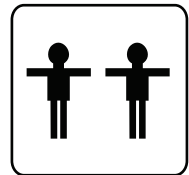
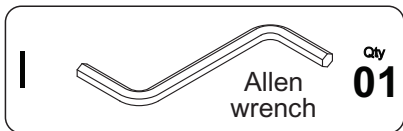
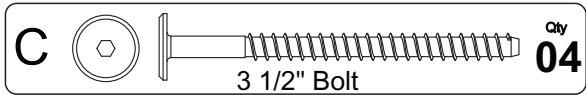
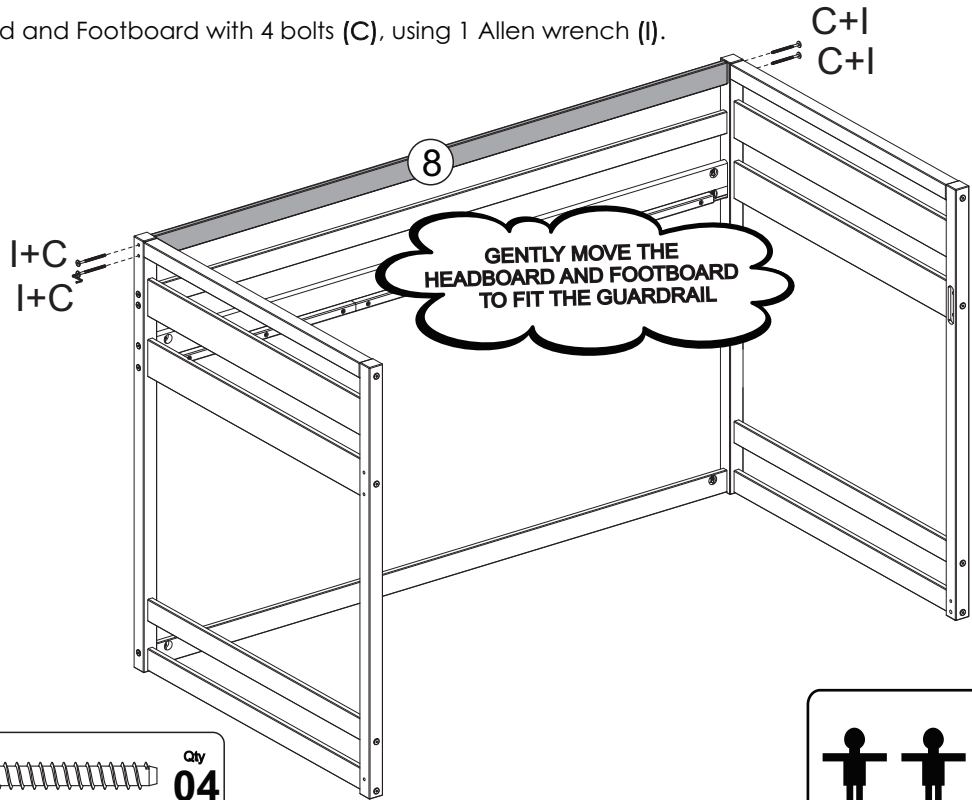
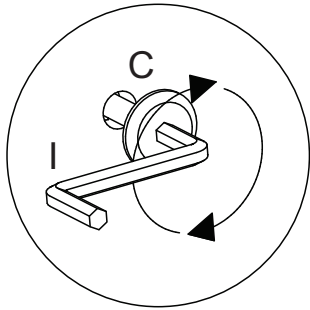

Important 2 people for assembly

Step 12

Bottom Rails

Attach part 11 on to Headboard and Footboard with 2 bolt (B) and 2 half moon (G), using 1 Allen wrench (I).

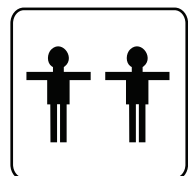
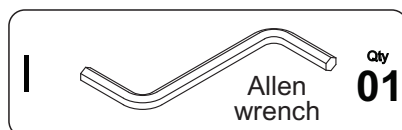
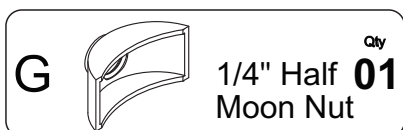
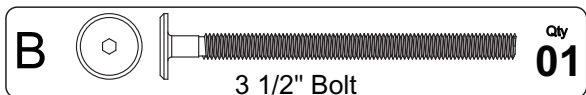
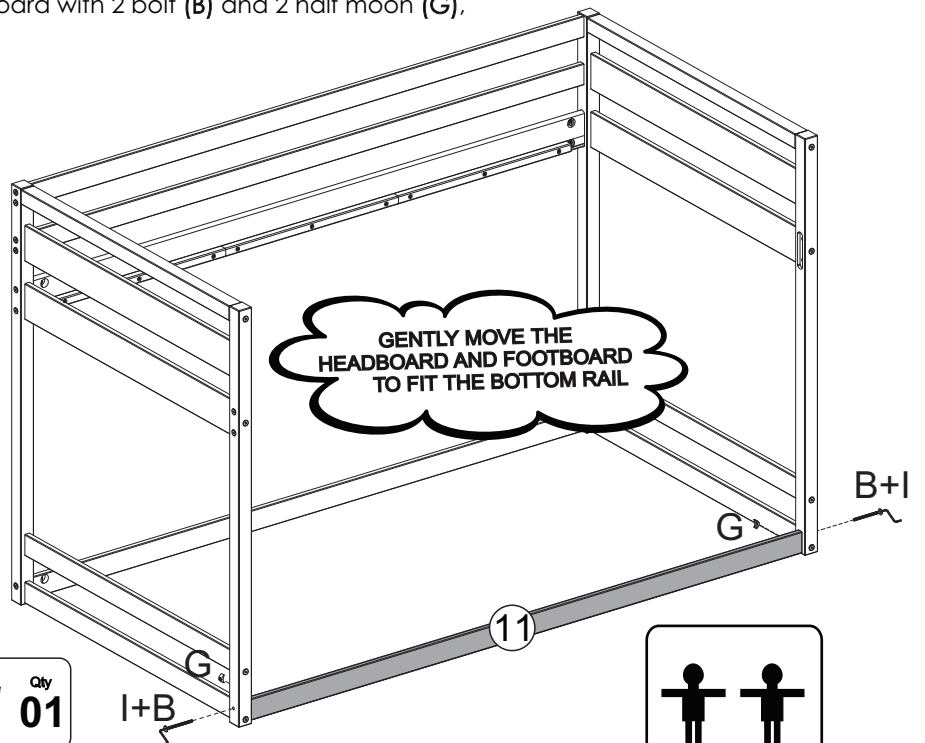
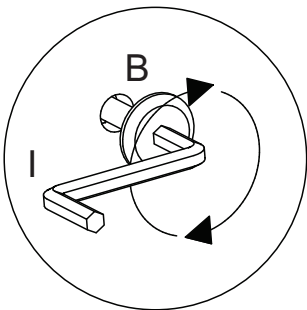

Important 2 people for assembly

Assembly Instructions

Step 13

Siderails

Attach part 12 on the Footboard and Headboard with 4 bolts (B), 4 Half Moons (G), using 1 Allen wrench (I).

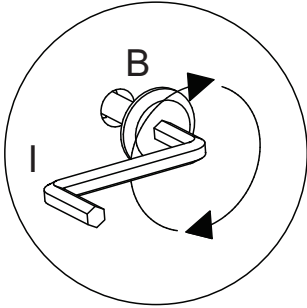

AFTER ATTACHING,
TIGHTEN ALL BOLTS
ON ENTIRE BED.

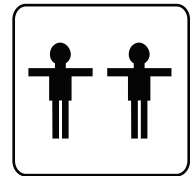
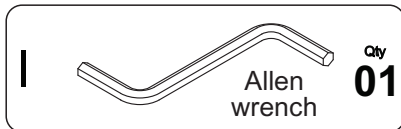
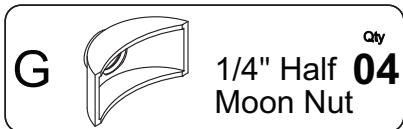
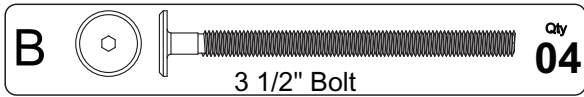
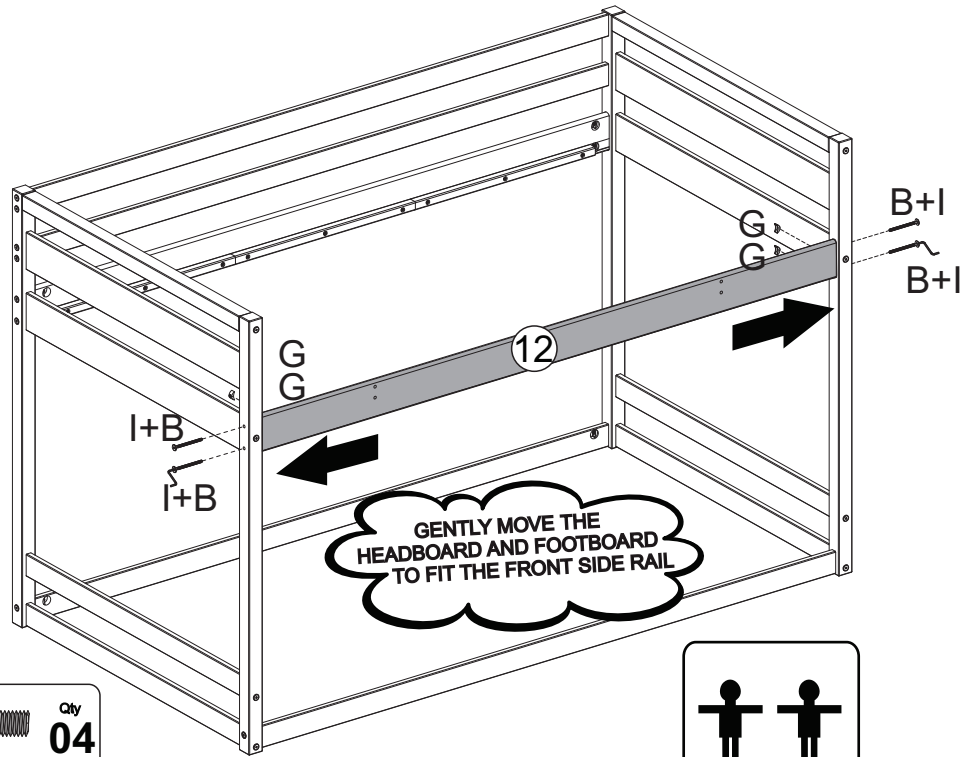

Important 2 people
for assembly

Step 14

Front Guardrail

Insert 4 wooden dowels (A) into the holes on to part 13, as shown in the diagram.

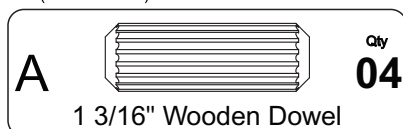
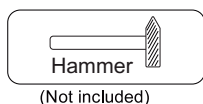
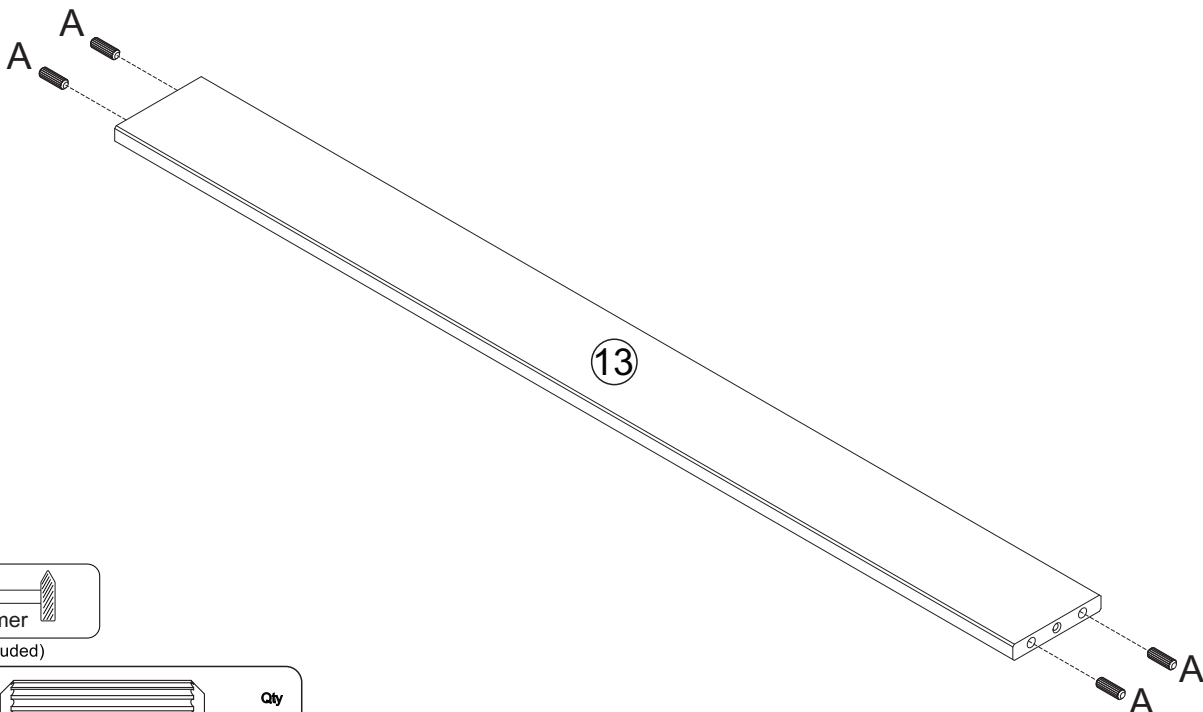
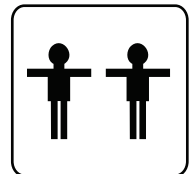

Assembly Instructions

Step 15

Front Guardrail

Attach part 16 on to parts 13 and 14 with 2 bolts (D), using 1 Allen wrench (I).

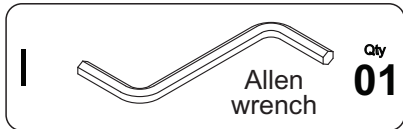
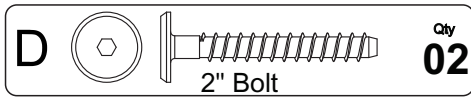
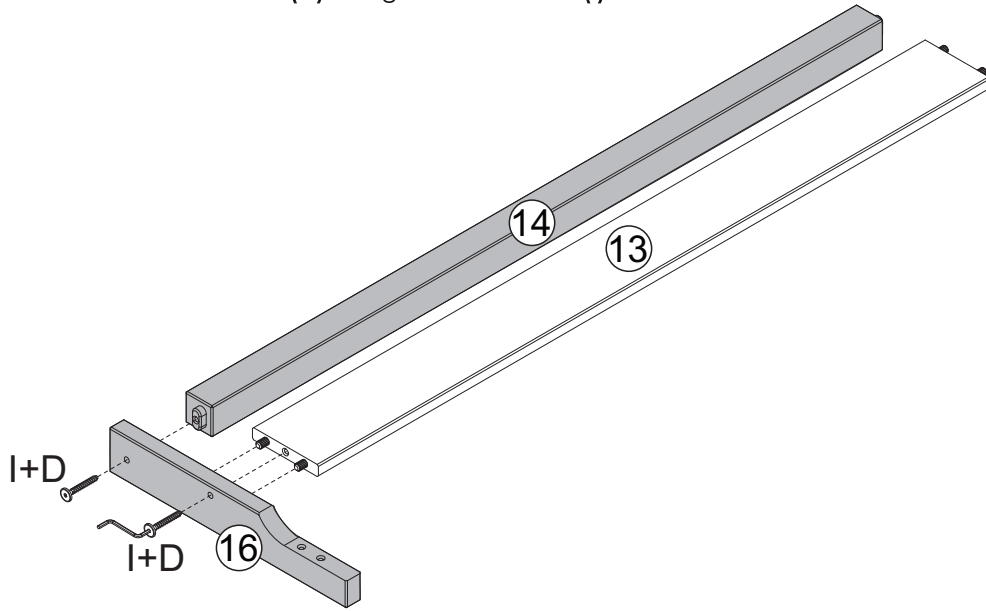

Step 16

Front Guardrail

Attach part 21 on to parts 13 and 14 with 2 bolts (D), using 1 Allen wrench (I).

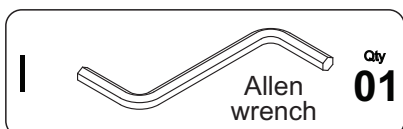
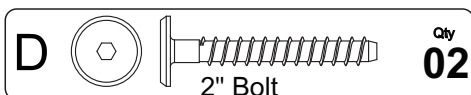
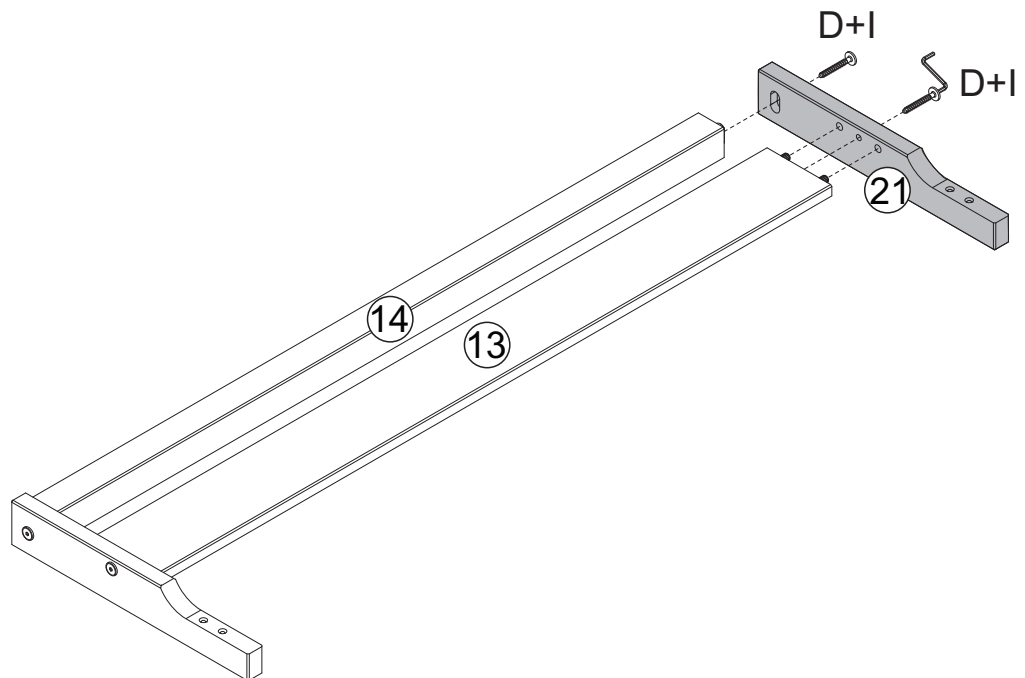

Assembly Instructions

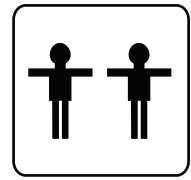

Step 17

Front Guardrail

Attached the Front Guardrail to the front rail part 12 with 4 bolts (D), using 1 Allen wrench (I).

Important 2 people for assembly

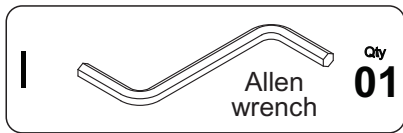
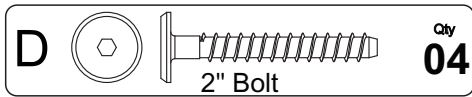
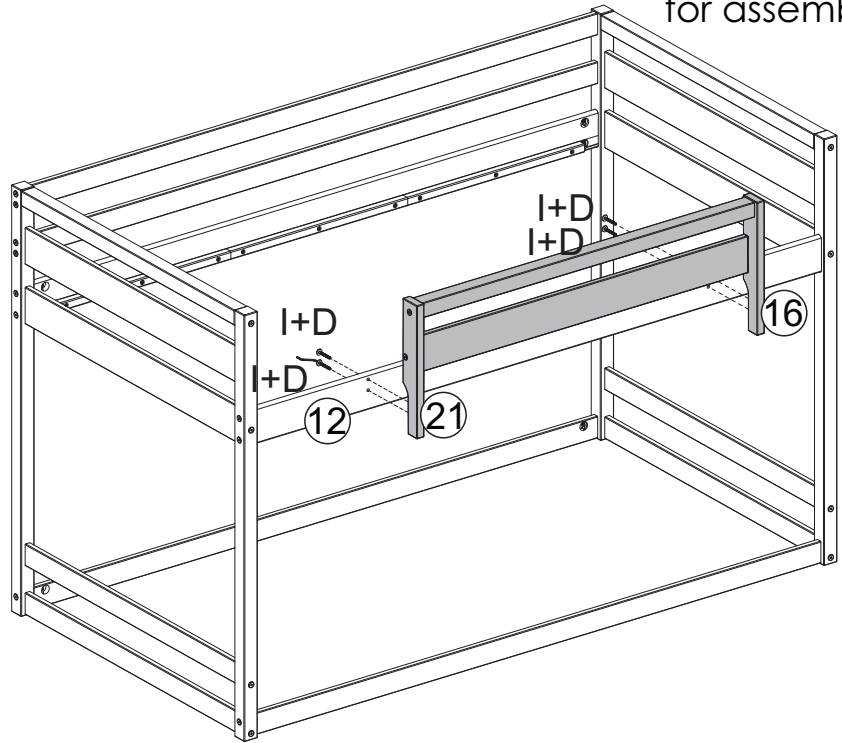
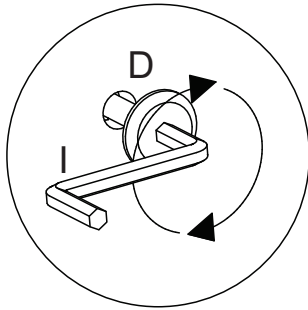

Step 18

Bed Slats

- 1) Attached the first slat to the end of the side rail base with 2 screws (E), using a phillips screwdriver.
- 2) Use the spacer (H) to limit the space between the slats.
- 3) Attach the slats 17 with 24 screws (E), using a phillips screwdriver.
- 4) Please note warping may occur because it is natural wood. To facilitate the placement of the screws, you must press the two siderails simultaneously.

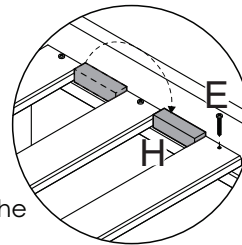

Important 2 people for assembly

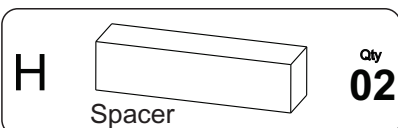
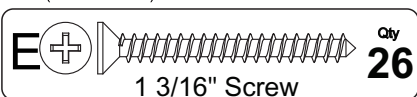
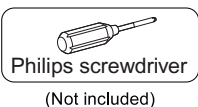
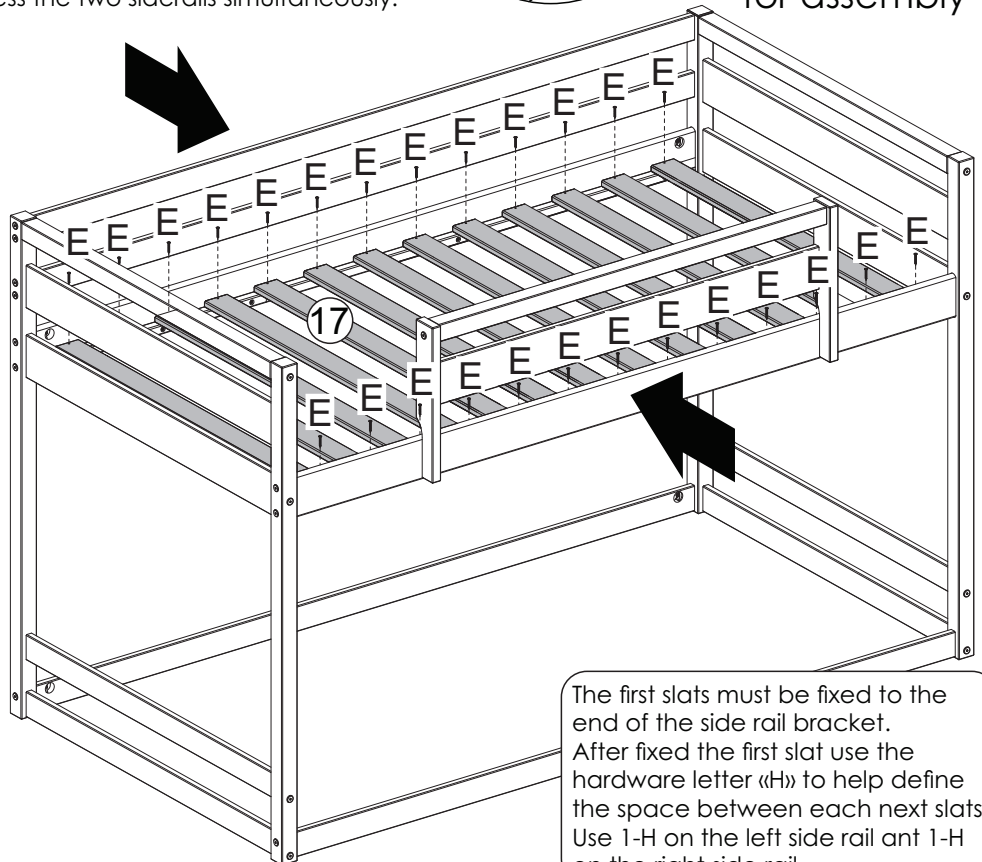
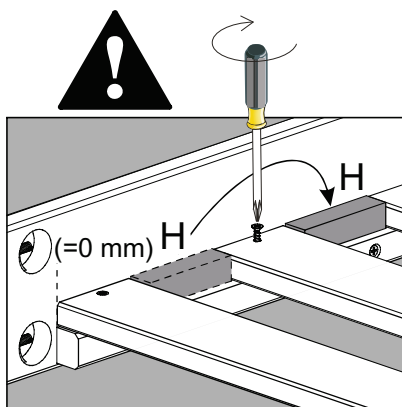

The first slats must be fixed to the end of the side rail bracket. After fixed the first slat use the hardware letter «H» to help define the space between each next slats. Use 1-H on the left side rail and 1-H on the right side rail

Assembly Instructions

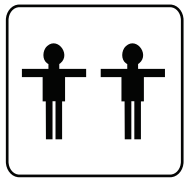

Step 19

Guardrail reinforcement

Attach parts 9 on to parts 8 and 21 with 8 screws (E) using Philips screwdriver.

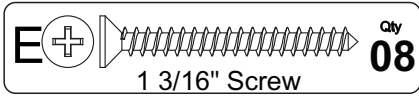
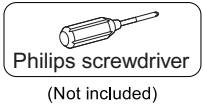
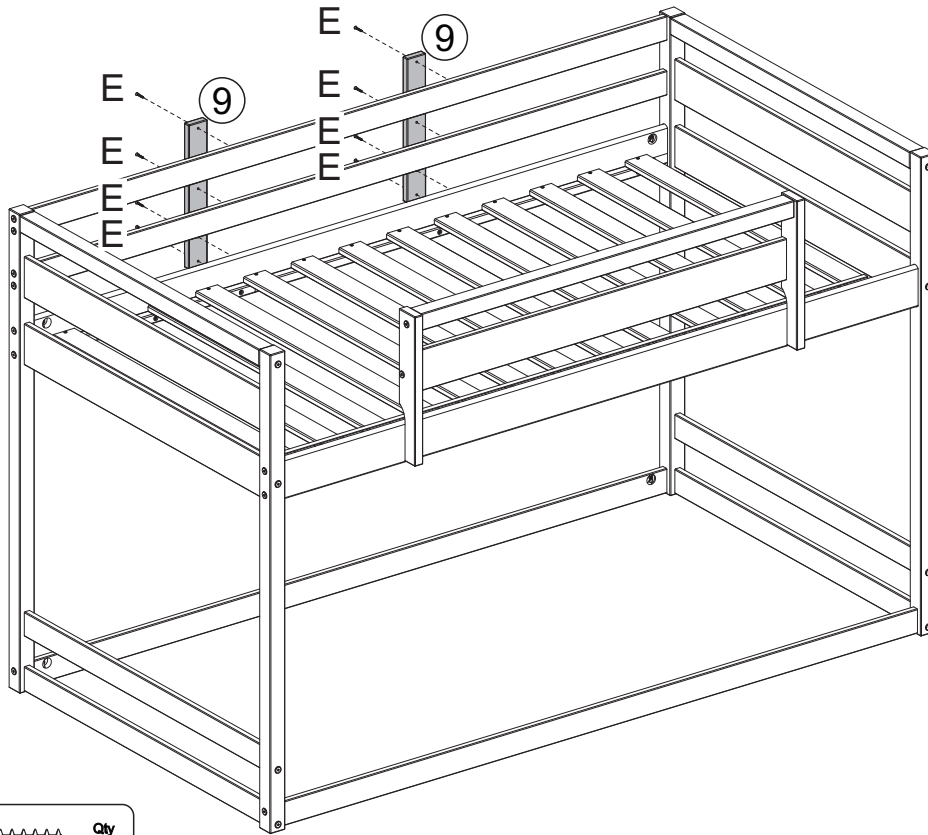

Step 20

Ladder

Insert 6 wooden dowels (A) into the holes on to parts 19, as shown in the diagram.

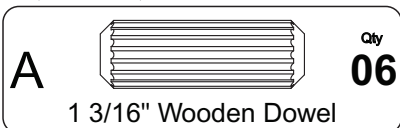
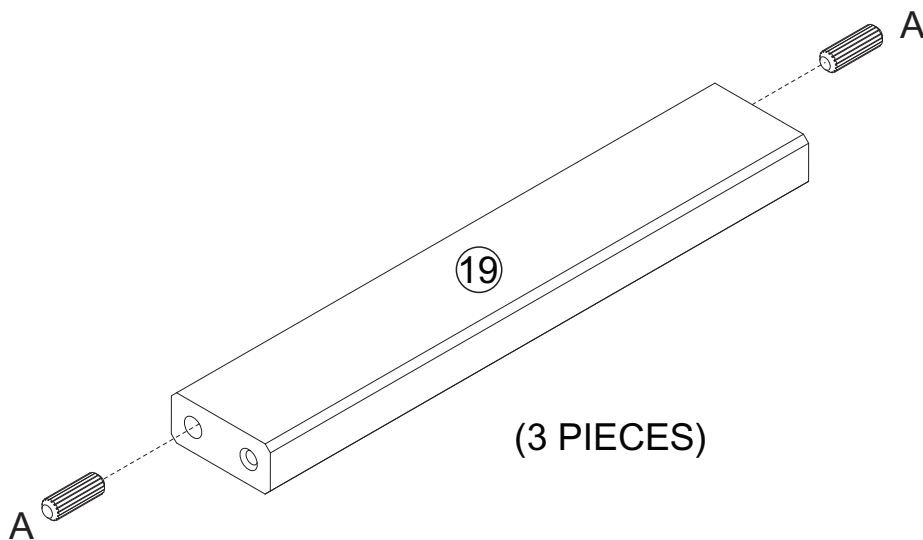

Assembly Instructions

Step 21

Ladder

Attach parts 19 on to part 18 with 3 bolts (D), using 1 Allen wrench (I).

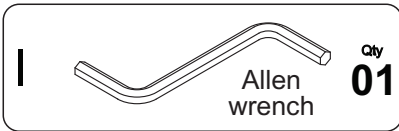
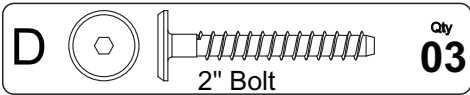
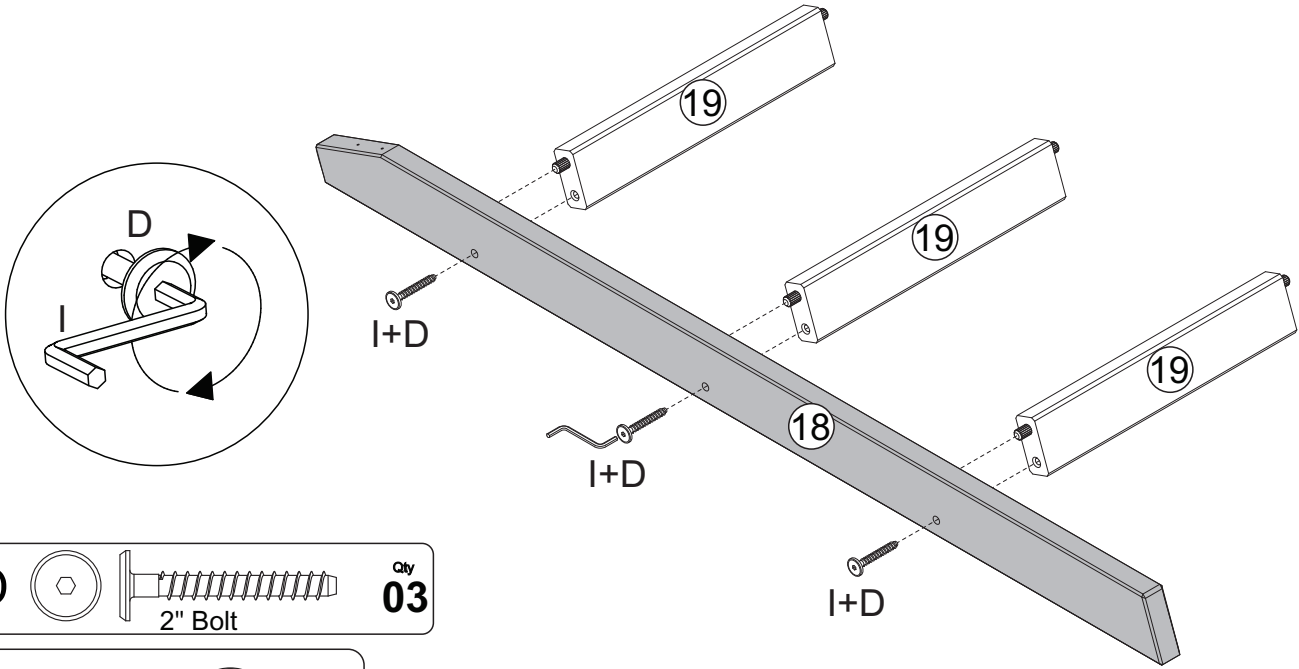

Step 22

Ladder

Attach parts 19 on to part 20 with 3 bolts (D), using 1 Allen wrench (I).

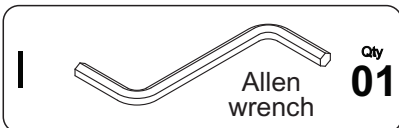
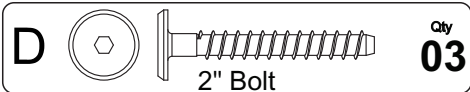
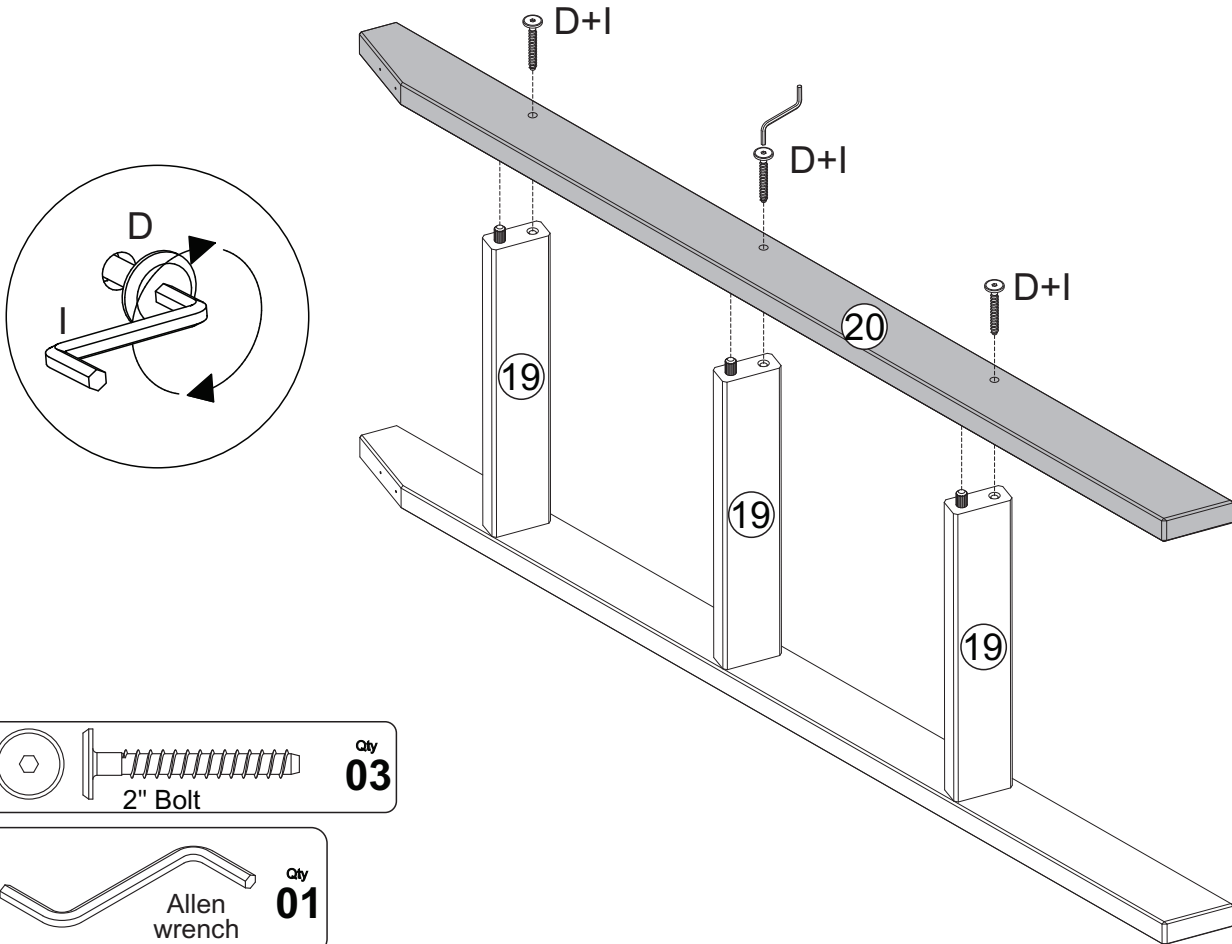

Assembly Instructions

Step 1

Step 23

Ladder

Attach 2 Hook Ladder (H) on to parts 18 and 20 with 4 screws (F) using Phillips screwdriver.

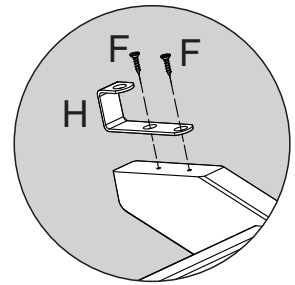

Step 2

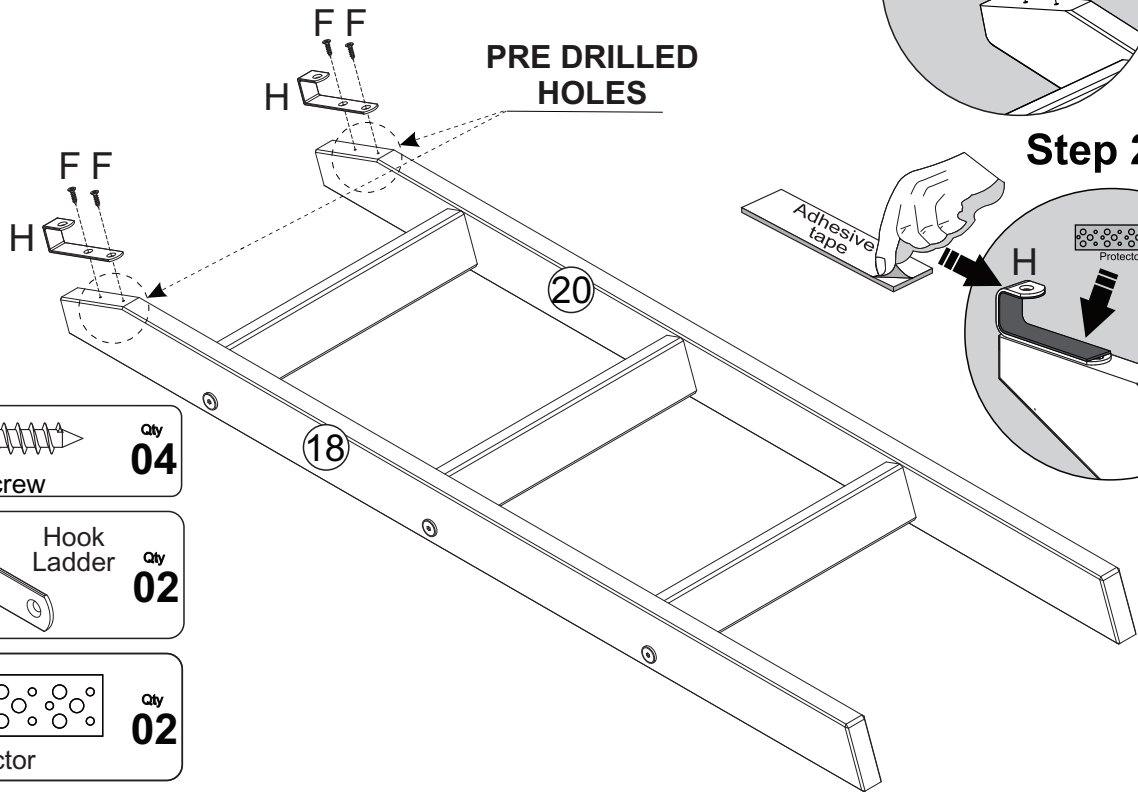
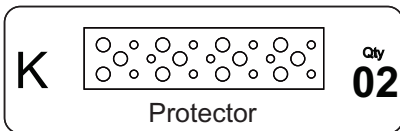
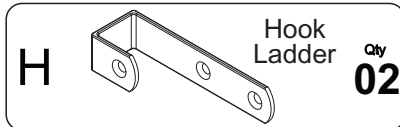
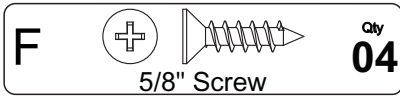
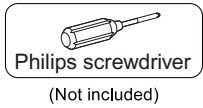
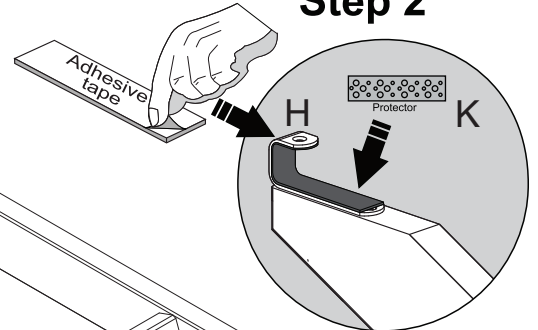

Step 24

Ladder

Please note that you can assemble the ladder on either the right or left side. Attach Ladder on to Front Bedrail with 2 screws (F) using Phillips screwdriver.

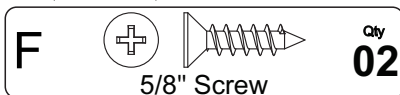
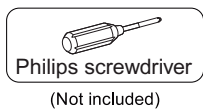
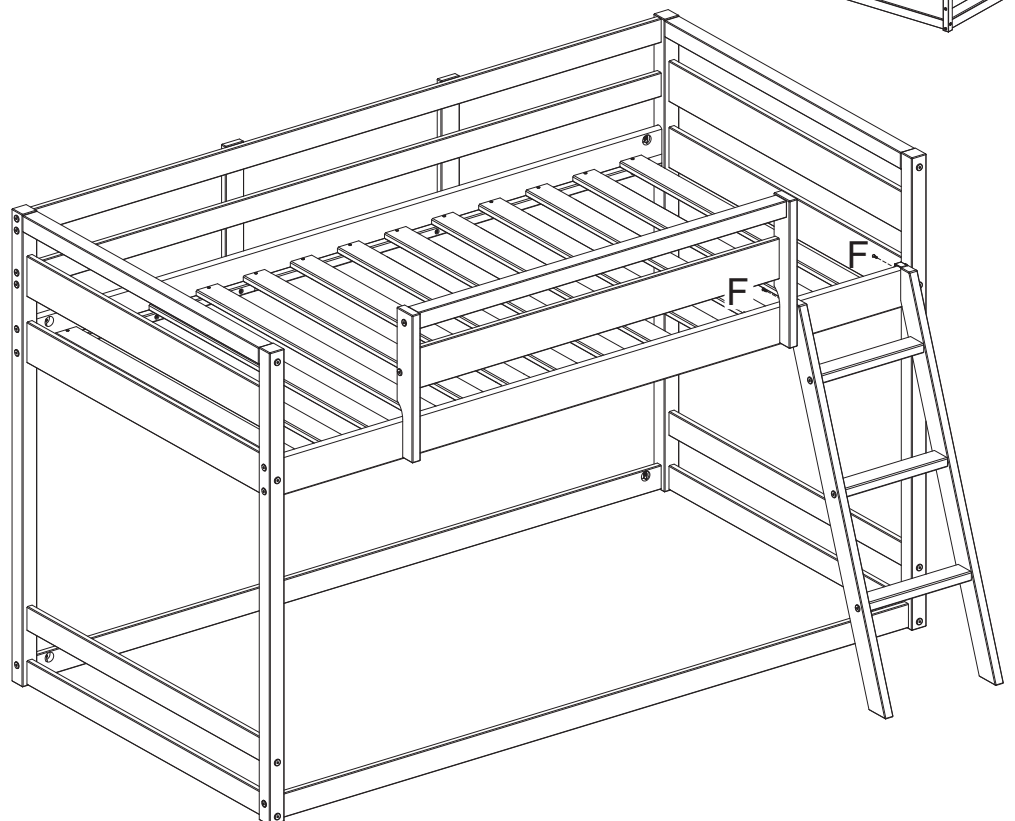
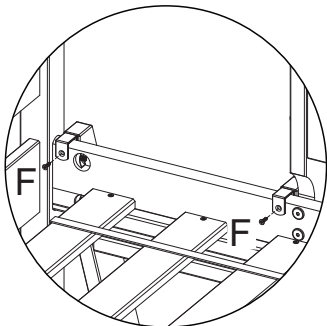
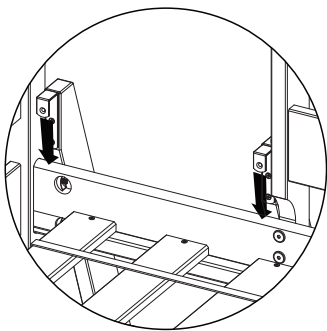
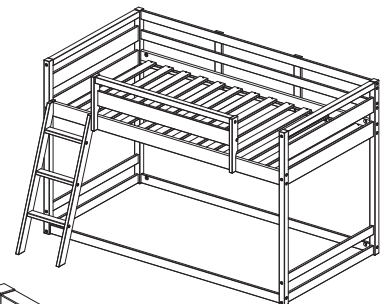

Return Policy:

- For products purchased through our retail partners please contact them for resolution prior to contacting P'kolino.
- At P'kolino it is our commitment to improve play at home with products that are playfully-stylish and functionally-smart. That means, we want you and the child(ren) to love the way our products look and work. If within 10 days of receipt your product you are not satisfied you may return it for a refund of the merchandise value.
- Our products and packaging have been designed to withstand standard delivery methods, however, please inspect your product upon receipt for damage to the packaging as products damaged during shipping are subject to exchange or refund. If product has been visibly damaged it is recommended that you refuse the delivery by the carrier. Notify us of the shipment rejection and upon receipt of the rejected shipment we will send you a replacement at no charge.
- To return your product, contact the retailer you purchased your product from. For products with visible wear or that are not properly repackaged will incur a restocking fee of 10%. Please follow assembly, use and care instructions carefully as we will not accept returns on products damaged due to improper assembly, altered or modified products, or on items damaged from normal, excessive or unintended use. Return shipping expenses, unless otherwise specifically stated by P'kolino, will be the customers expense.
- If you have questions regarding our policy please contact us at customercare@pkolino.com or 888-403-8992.

Warranty:

- P'kolino products are guaranteed to be free from defects in material and workmanship under normal and intended use for a period of 30 days from the date of your purchase.

Replacement/Credit:

- If our product fails to meet our warranty during the warranty period, we will, at our option, replace the product or provide you with a replacement of comparable value.

What Our Limited Warranty Does Not Cover:

- We offer this limited warranty only when the product is used by the original end-user customer. We offer no other warranty. Additionally, while our warranty is excellent, there are other limits to it. We offer NO WARRANTY in cases of damage in transit, inadequate care, abuse, abnormal use, misuse, accidents, normal wear and tear, damage due to environmental or natural elements, failure to follow product instructions, immersion in water (except for products specifically identified by us in writing as intended for water use), or improper storage or maintenance of the products.

Limitation on Damages:

- IN NO EVENT SHALL P'KOLINO,LLC BE LIABLE FOR INCIDENTAL, COMPENSATORY, PUNITIVE, CONSEQUENTIAL, INDIRECT, SPECIAL OR OTHER DAMAGES. OUR AGGREGATE LIABILITY WITH RESPECT TO DEFECTIVE PRODUCTS IS LIMITED TO THE MONIES PAID TO US FOR THE DEFECTIVE GOOD.

Some states and countries do not allow the exclusion or limitation of incidental, consequential or other damages, so the above limitation or exclusion may not apply to you. This warranty gives you specific legal rights, and you may also have other rights which vary based on state, province or country.

Contact Information

Please feel free to contact us at the address listed below

P'kolino LLC • 7300 NW 35th Avenue • Miami, FL 33147 • USA

CARE AND MAINTENANCE:

MAINTENANCE:

- Our furniture is designed to be low maintenance, however misuse, irregular use, or improper assembly can result in product malfunction. Regularly check the stability. If pieces feel loose or wobbly tighten all screws immediately.
- To store, review Assembly Instructions and reverse the steps to disassemble.
- Use only provided hardware to assemble and maintain assembly.

CARE:

- To clean use a soft, lint free rag similar to a cloth diaper and wipe away dust regularly. If necessary dampen cloth slightly with warm water and gently rub away spots. Dry thoroughly.
 - Do not use a bleach solution.
 - Do not submerge or allow to lie in standing water.
 - Do not use a sponge or harsh abrasive.
 - Do not use all purpose cleaners or harsh detergents.
 - Do not use Pine Oil cleaners or abrasive household cleaners.
 - Do not use heat or hot water.

ABOUT WOOD AND FINISH:

This product has been carefully crafted of MDF, solid pine wood and/or pine veneers. These materials derive from plantations, a renewable and well managed forest, therefore, not endangering the environment. The highest quality standards have been implemented to assure a sturdy and reliable product. Due to the natural variances in the graining of wood, you may notice subtle differences in the shading and tone of the color stain, warp, holes, wood knots and also small cracks. This is not a defect. But rather a result of the natural beauty of the wood itself.

PLEASE REGISTER THIS PRODUCT AT: WWW.PKOLINO.COM/REGISTER

California 93120 compliant for formaldehyde Phase 2 TPC-AQCARB-03