

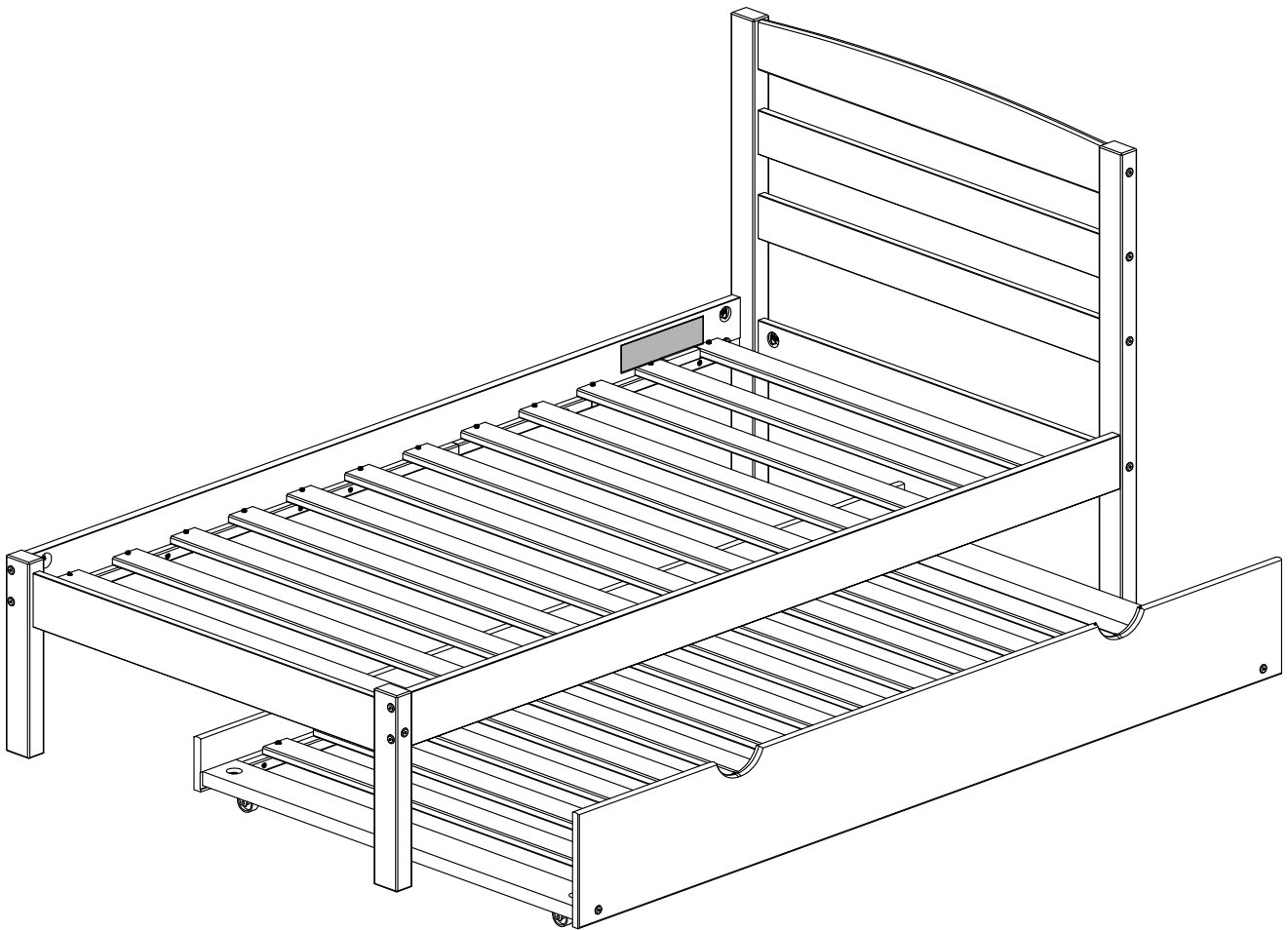

Twin Bed with Trundle



**READ ALL INSTRUCTIONS BEFORE ASSEMBLING TWIN BED.
KEEP INSTRUCTIONS FOR FUTURE USE.
THE ASSEMBLY OF THIS PRODUCT REQUIRES TWO ADULTS.**



WARNING:

Failure to follow these warnings and the assembly instructions could result in serious injury or death.

**Twin bed is intended for home use, not to be used in public institutions.
(hospitals, daycares, etc.)**



WARNING:

ADULT ASSEMBLY REQUIRED.

Product must be assembled by an adult before use.

After assembly has been completed, all remaining materials and packages are to be recycled according to the regulations in force and kept out of children's reach. Components left after the assembly are not intended for play.

This Box Contains:

Twin Bed Parts:

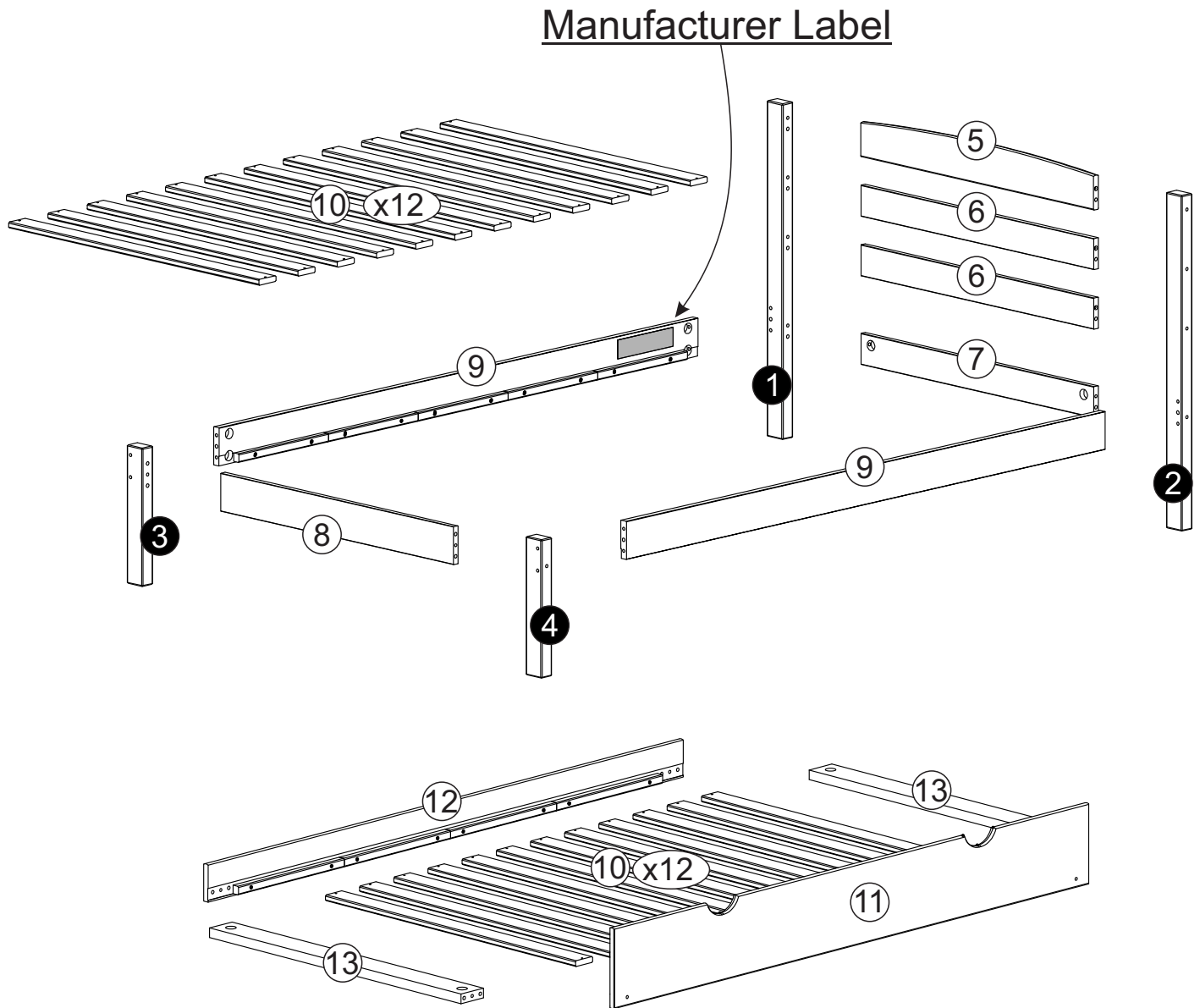

Tools required

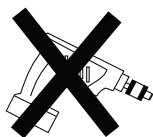
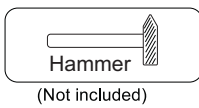
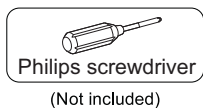

You will need a Phillips head screwdriver and a hammer

Hardware:

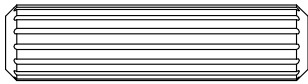

24 Wooden dowel 10x40 (A)

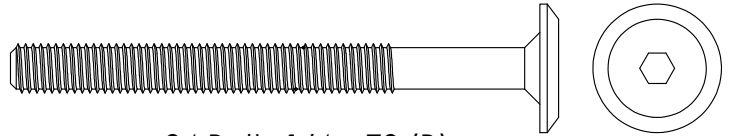

04 Bolts 1/4 x 70 (B)

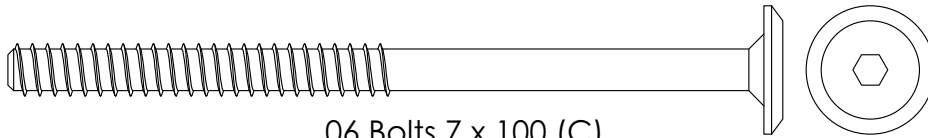

06 Bolts 7 x 100 (C)

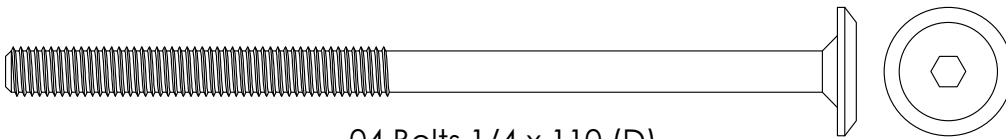

04 Bolts 1/4 x 110 (D)

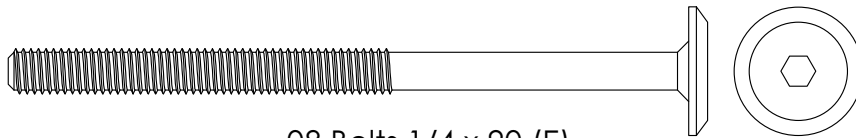

08 Bolts 1/4 x 90 (E)

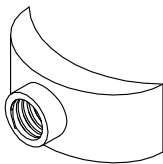

16 Elliptical nuts (F)

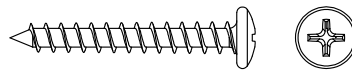

48 Screws 4 x 30 (G)

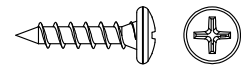

16 Screws 3.5 x 16 (H)

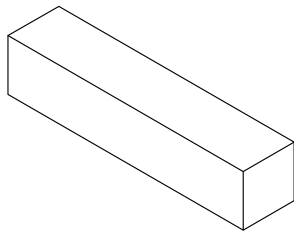

2 Wooden spacers 88mm (I)
Twin bed

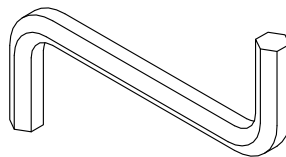

1 Allen wrench (J)

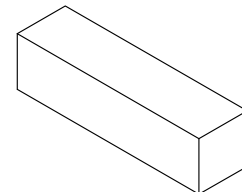

2 Wooden spacers 68mm (K)
Trundle

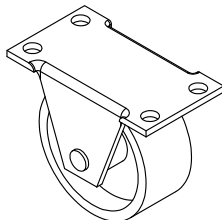

04 Casters (L)

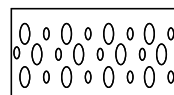

04 Adhesive felt (M)

FOR MISSING PARTS OR HARDWARE:

DO NOT CONTACT THE STORE WHERE YOU MADE YOUR PURCHASE.

Please contact the manufacturer directly at customercare@pkolino.com or 888-403-8992.

For customer service cases involving hardware please provide the part number.

Assembly Instructions

THE USE OF POWER TOOLS IS NOT RECOMMENDED BECAUSE THEY CAN DAMAGE HARDWARE AND/OR SPLIT THE WOOD.

Step 1

Headboard panels

1) Insert wooden dowels (A) into the holes, as shown in the diagram.

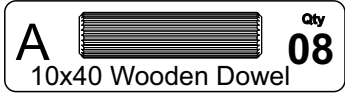
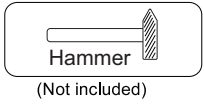
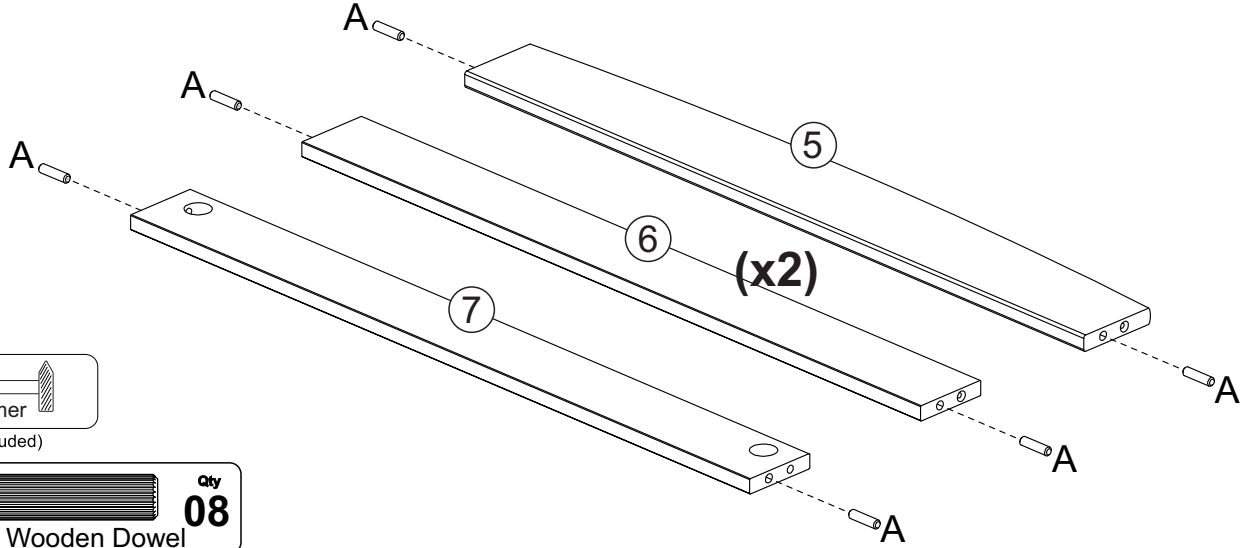

Step 2

Headboard

1) Attach parts 5, 6 and 7 on the post 1 and 2 with 2 bolts (D), 2 elliptical nuts (F) and 6 bolts (C), using the allen wrench (J).
 3) Remove the paper from the adhesive felt (M) and attach to the bottom of the posts 1 and 2

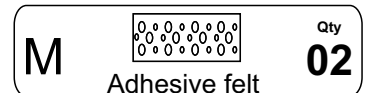
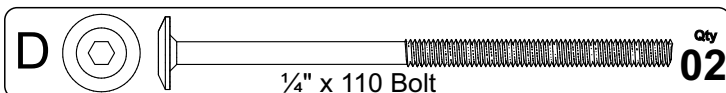
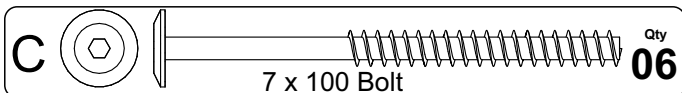
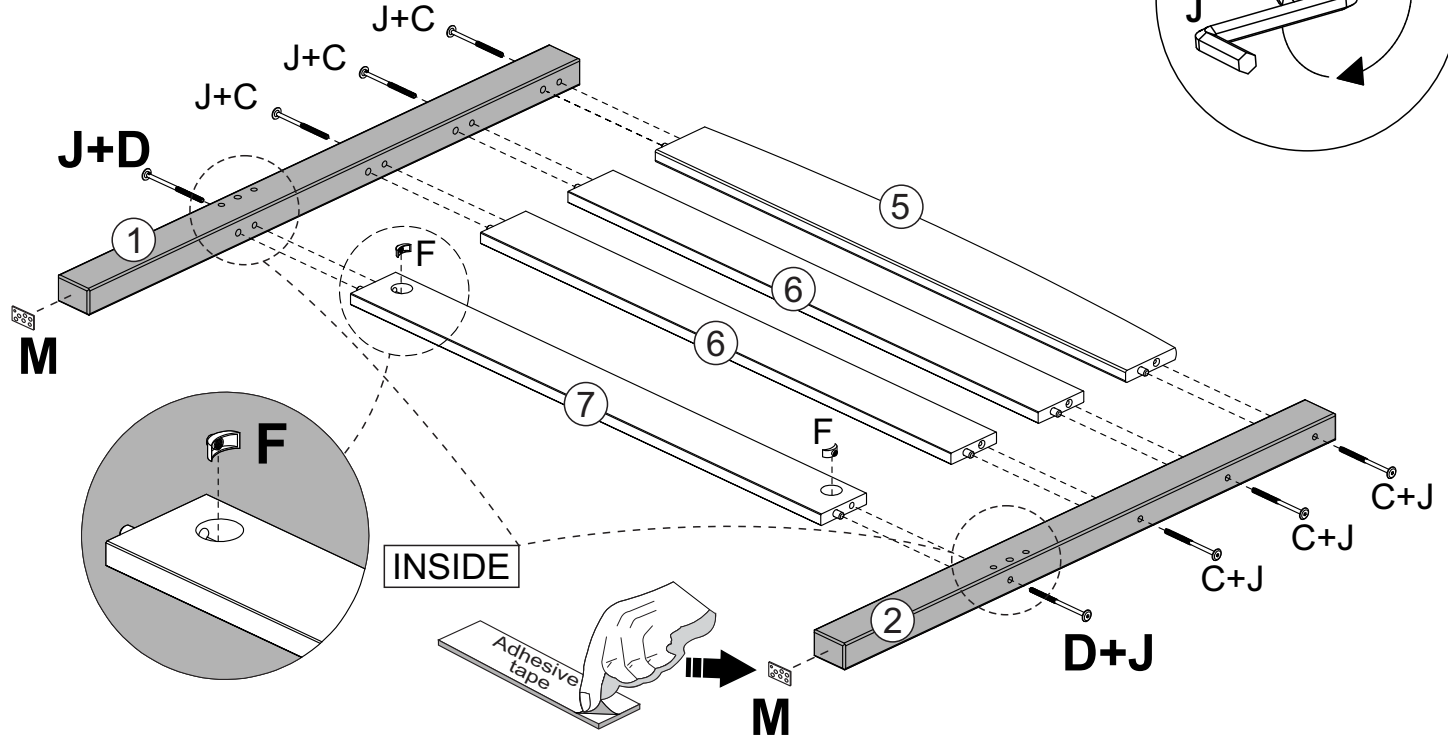
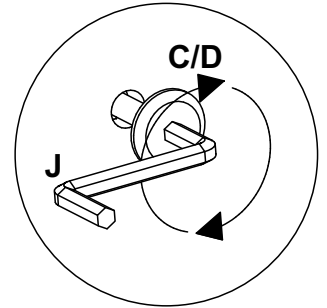

Assembly Instructions

THE USE OF POWER TOOLS IS NOT RECOMMENDED BECAUSE THEY CAN DAMAGE HARDWARE AND/OR SPLIT THE WOOD.

Step 3

Footboard panel

1) Insert wooden dowels (A) into the holes, as shown in the diagram.

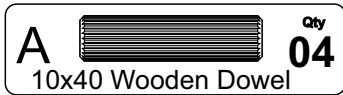
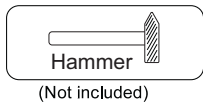
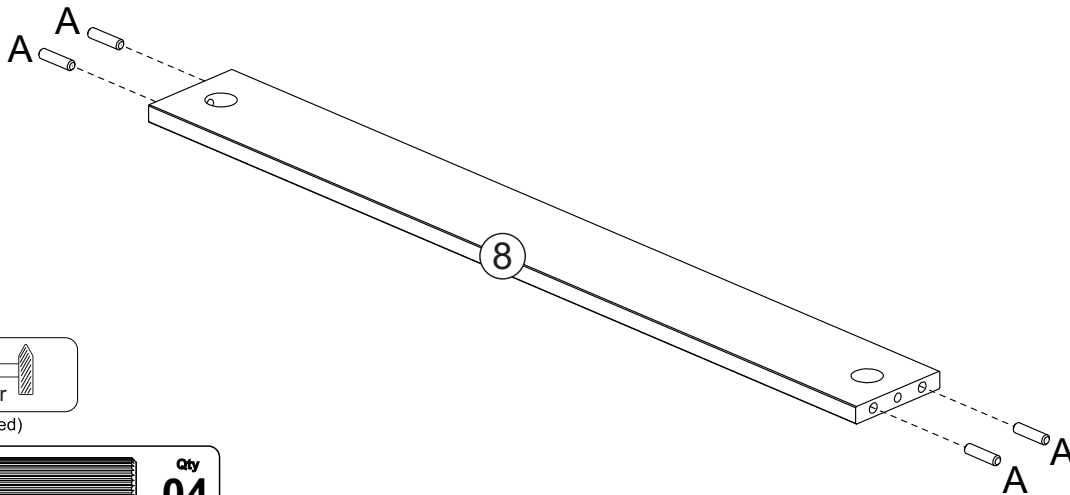

Step 4

Footboard

1) Attach footboard panel 8 on the posts 3 and 4 with 2 bolts (D) and 2 elliptical nuts (F) using the allen wrench (J).

3) Remove the paper from the adhesive felt (M) and attach to the bottom of the posts 3 and 4

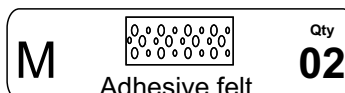
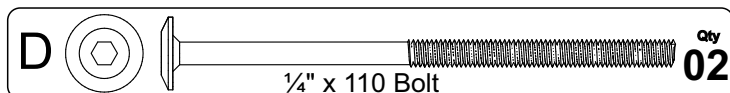
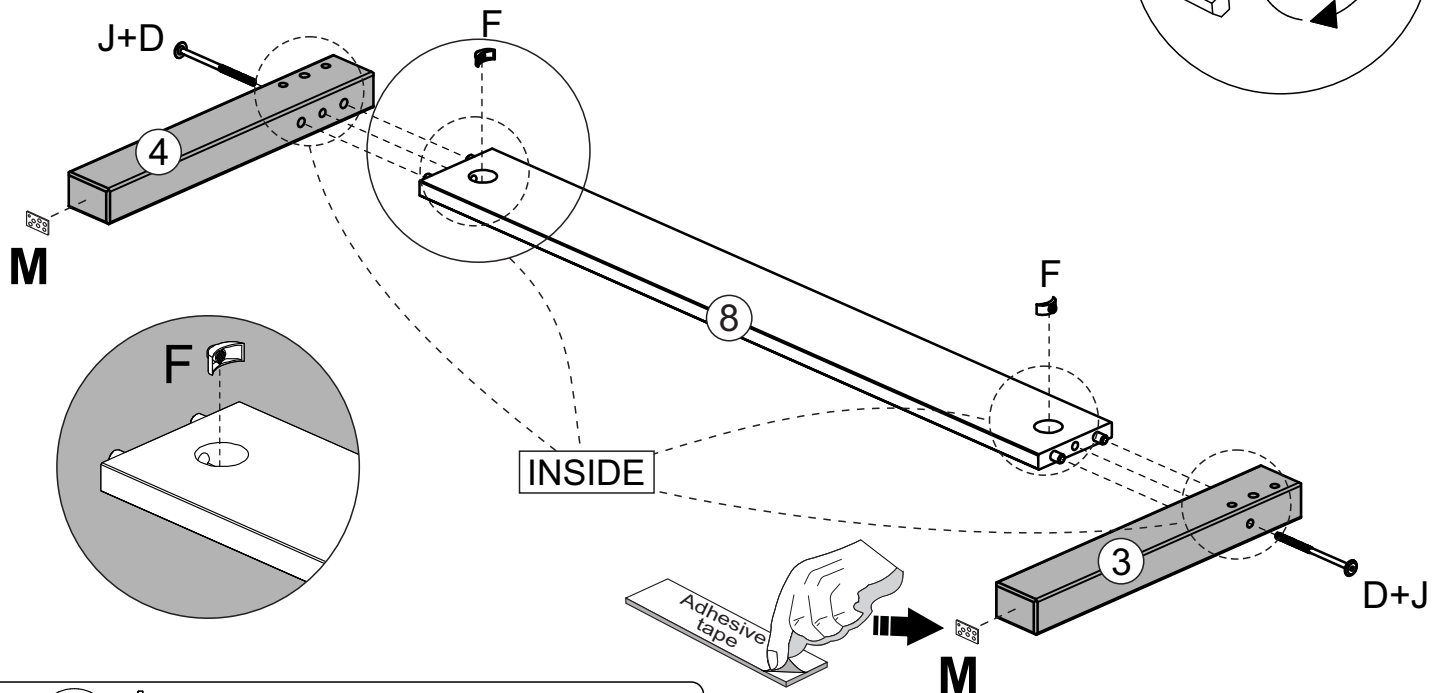
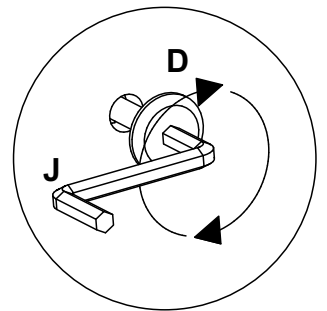

Assembly Instructions

THE USE OF POWER TOOLS IS NOT RECOMMENDED BECAUSE THEY CAN DAMAGE HARDWARE AND/OR SPLIT THE WOOD.

Step 5

Rails

1) Insert wooden dowels (A) into the holes, as shown in the diagram.

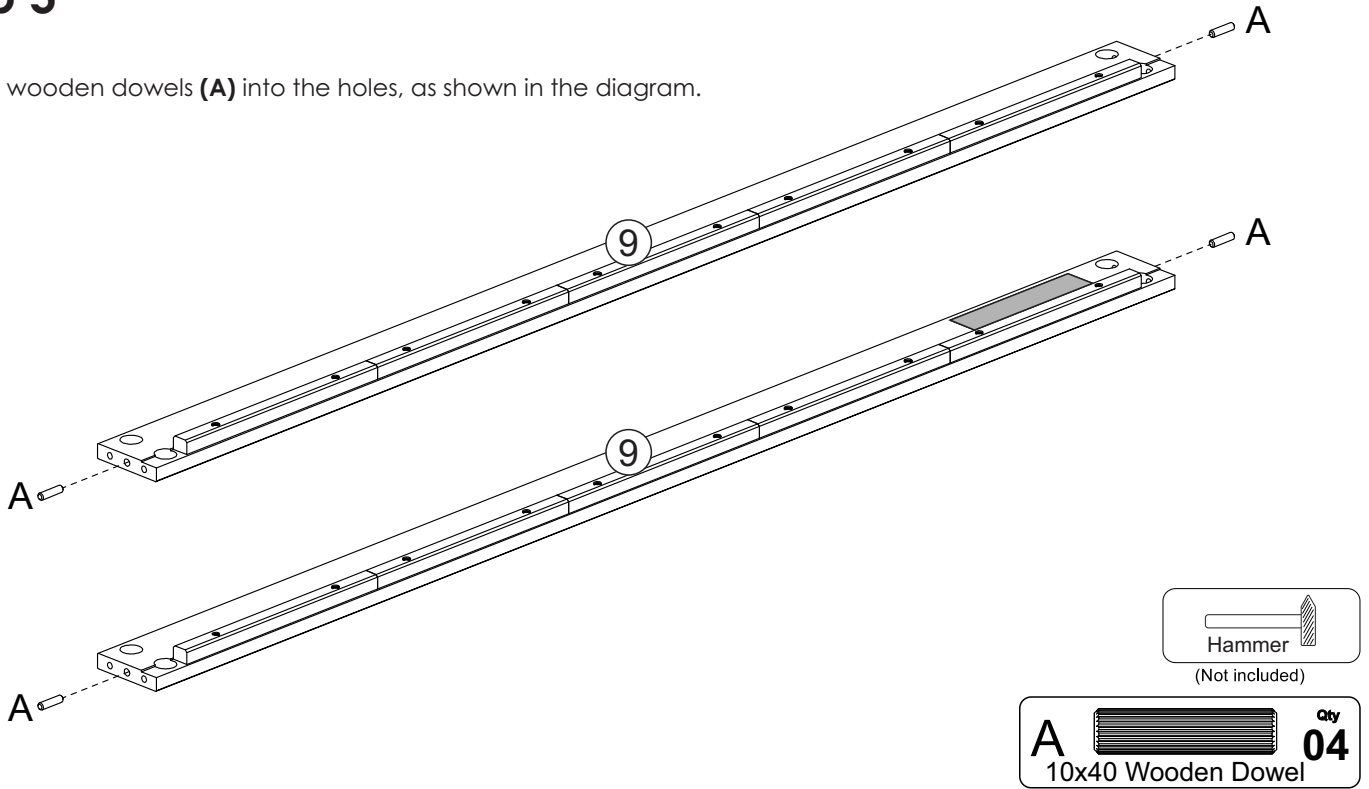

Step 6

Rails and headboard

1) Attach rails 9 on the headboard, with 4 bolts (E), and 4 elliptical nuts (F) using the allen wrench (J).

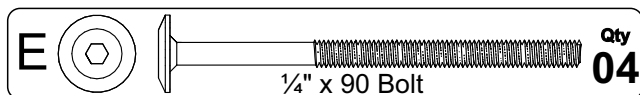
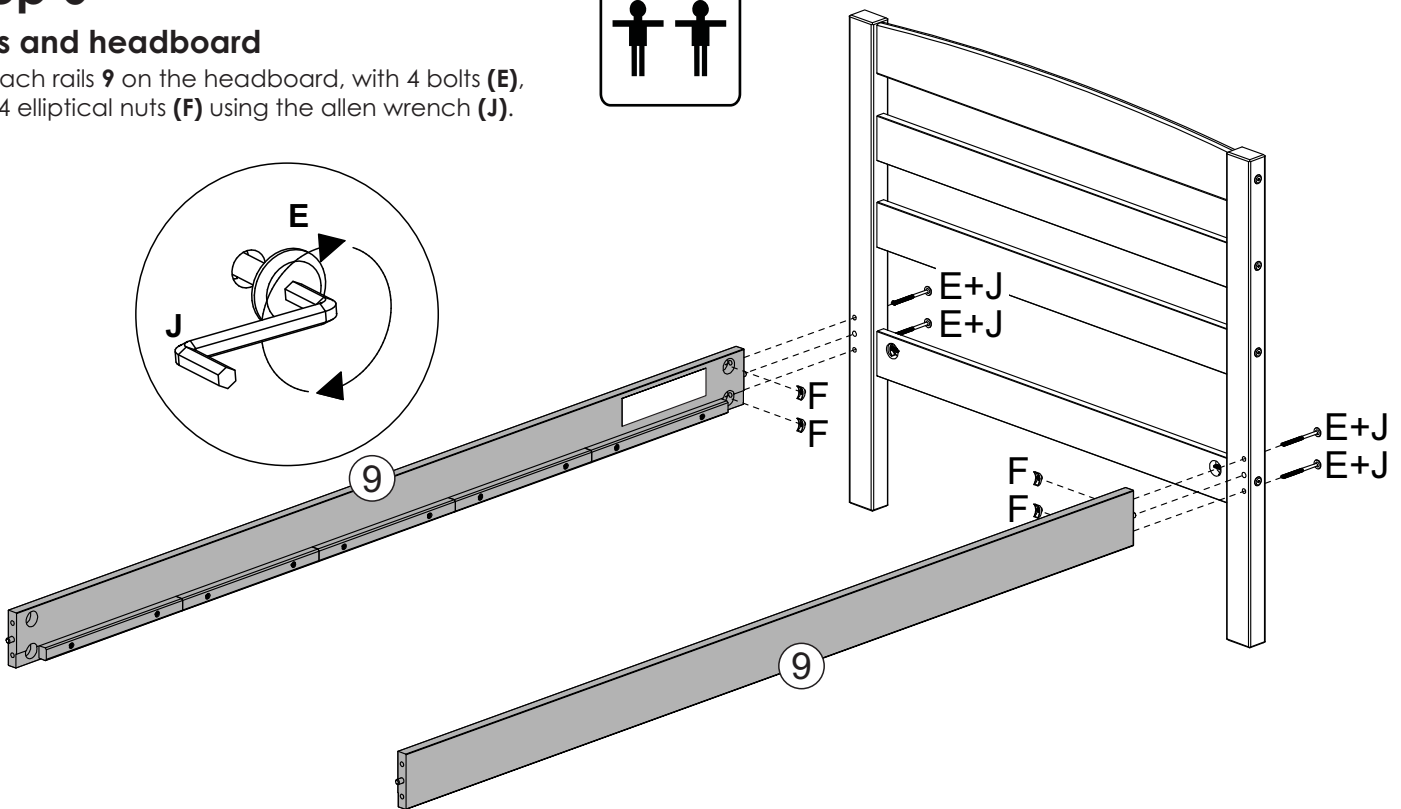
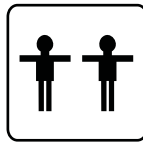

Assembly Instructions

THE USE OF POWER TOOLS IS NOT RECOMMENDED BECAUSE THEY CAN DAMAGE HARDWARE AND/OR SPLIT THE WOOD.

Step 7

Footboard

1) Attach footboard on the rails **9** with 4 bolts (**E**) and 4 elliptical nuts (**F**) using the allen wrench (**J**).

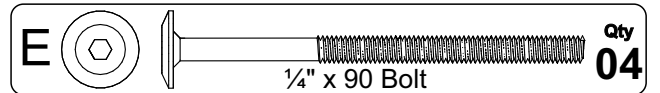
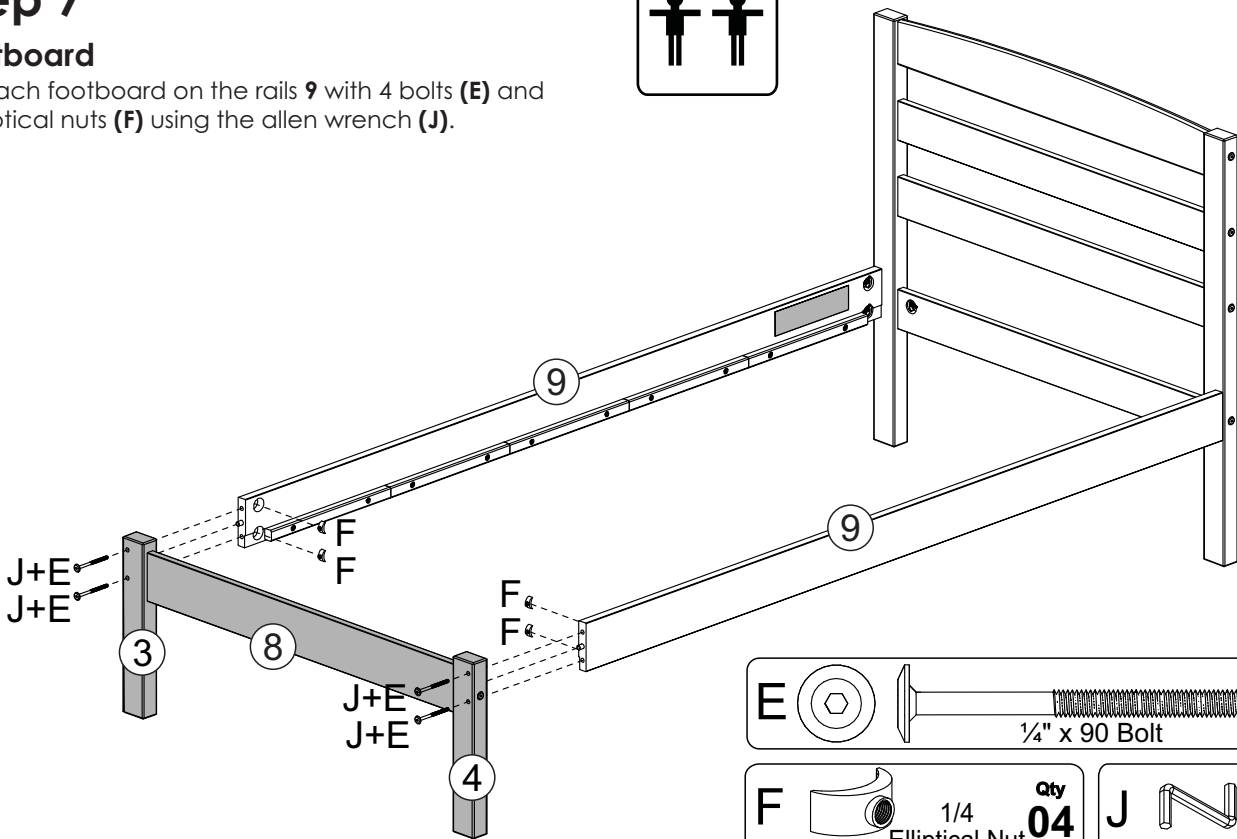
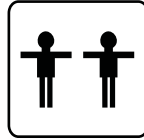

Step 8

Slats

1) Attach slats **10** on the rails with 24 screws (**G**);
 2) The first slat must be fixed to the end of the side rail bracket.
 3) After fixed the first slat use the hardware letter (**I**) to help define the space between each next slats.
 Use 1-(**I**) on the left side rail and 1-(**I**) on the right side rail.

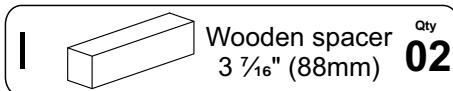
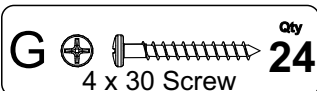
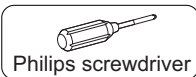
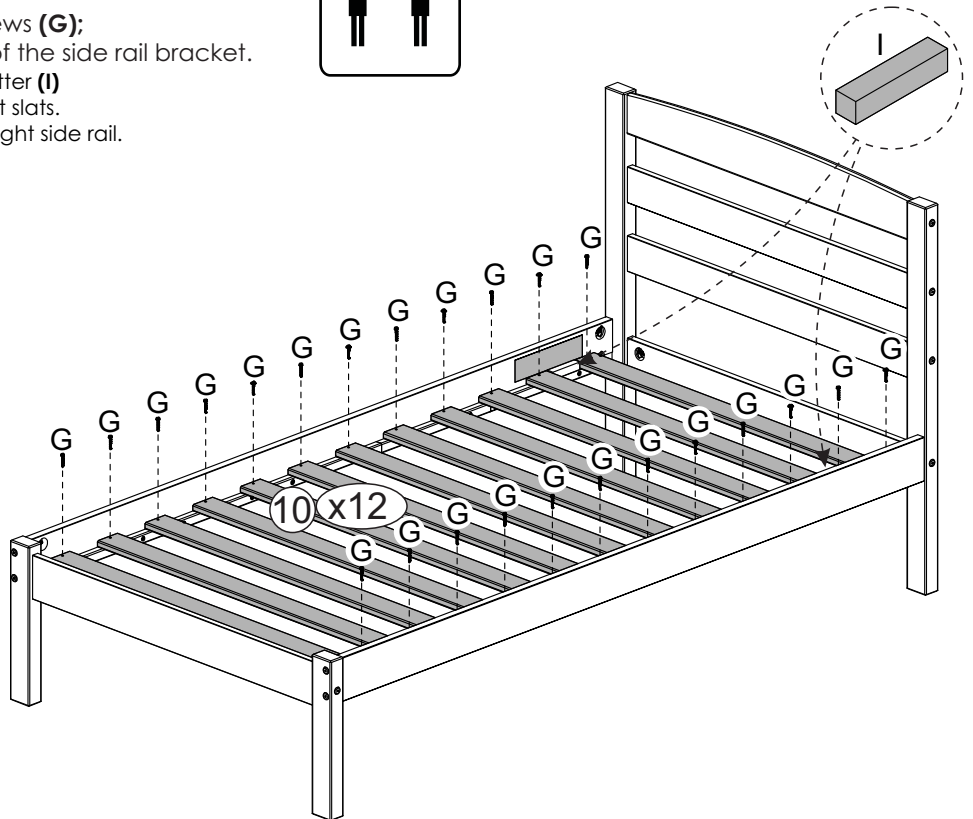
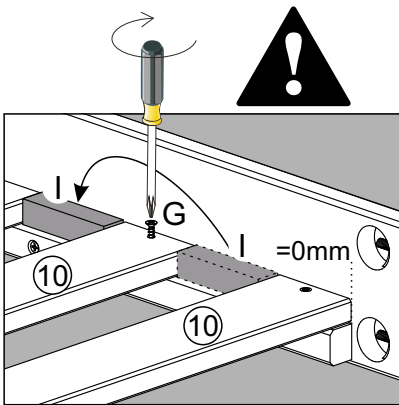
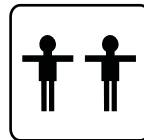

Assembly Instructions

THE USE OF POWER TOOLS IS NOT RECOMMENDED BECAUSE THEY CAN DAMAGE HARDWARE AND/OR SPLIT THE WOOD.

Step 9

(x2)

Trundle sides

1) Insert wooden dowels (A) into the holes, as shown in the diagram.

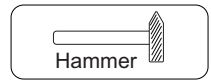
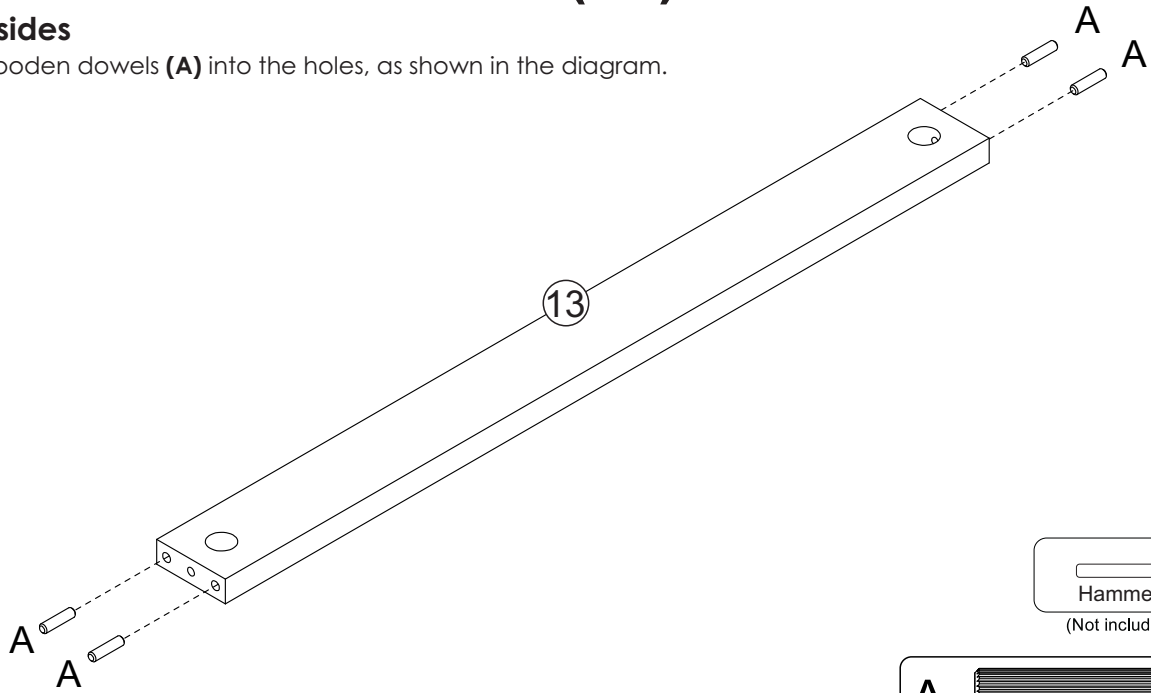

Hammer

(Not included)

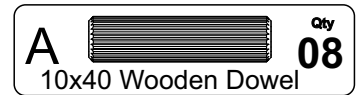

A 10x40 Wooden Dowel

Step 10

(x2)

Trundle sides

1) Attach the casters (L) in the trundle sides 13 with screws (H)

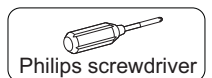
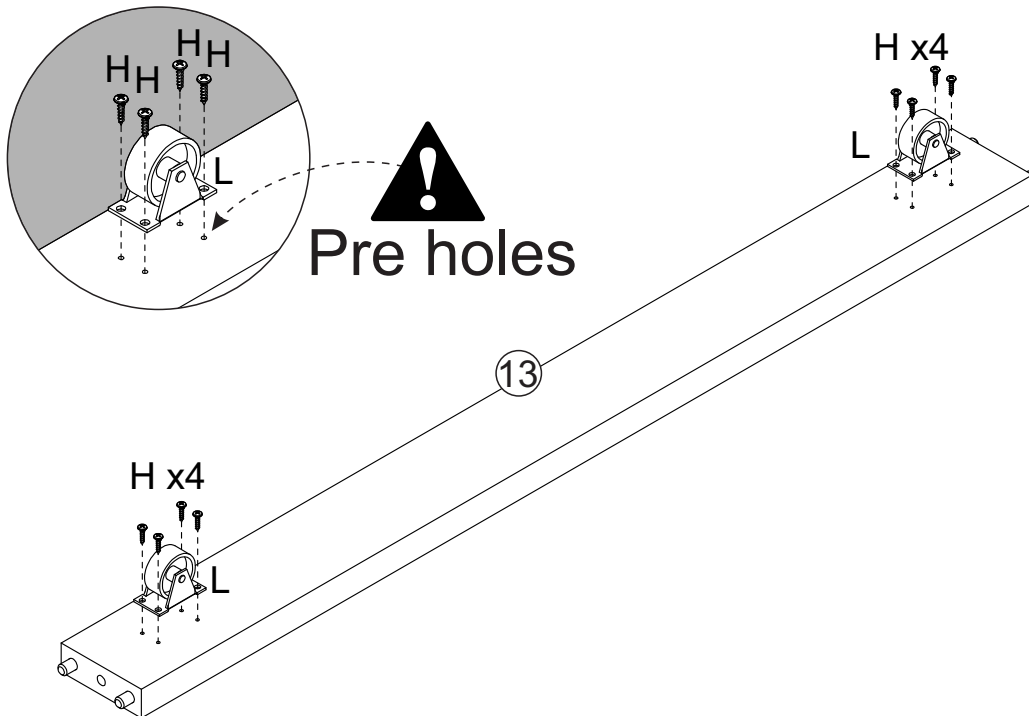

Philips screwdriver

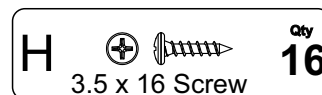

H 3.5 x 16 Screw



L Caster

Assembly Instructions

THE USE OF POWER TOOLS IS NOT RECOMMENDED BECAUSE THEY CAN DAMAGE HARDWARE AND/OR SPLIT THE WOOD.

Step 11

Trundle

- 1) Attach the sides to the front of the trundle with 2 bolts (B) and 2 elliptical nuts (F), using the allen wrench (J).
- 2) Attach the back side to the sides with 2 bolts (B) and 2 elliptical nuts (F) using the allen wrench (J).

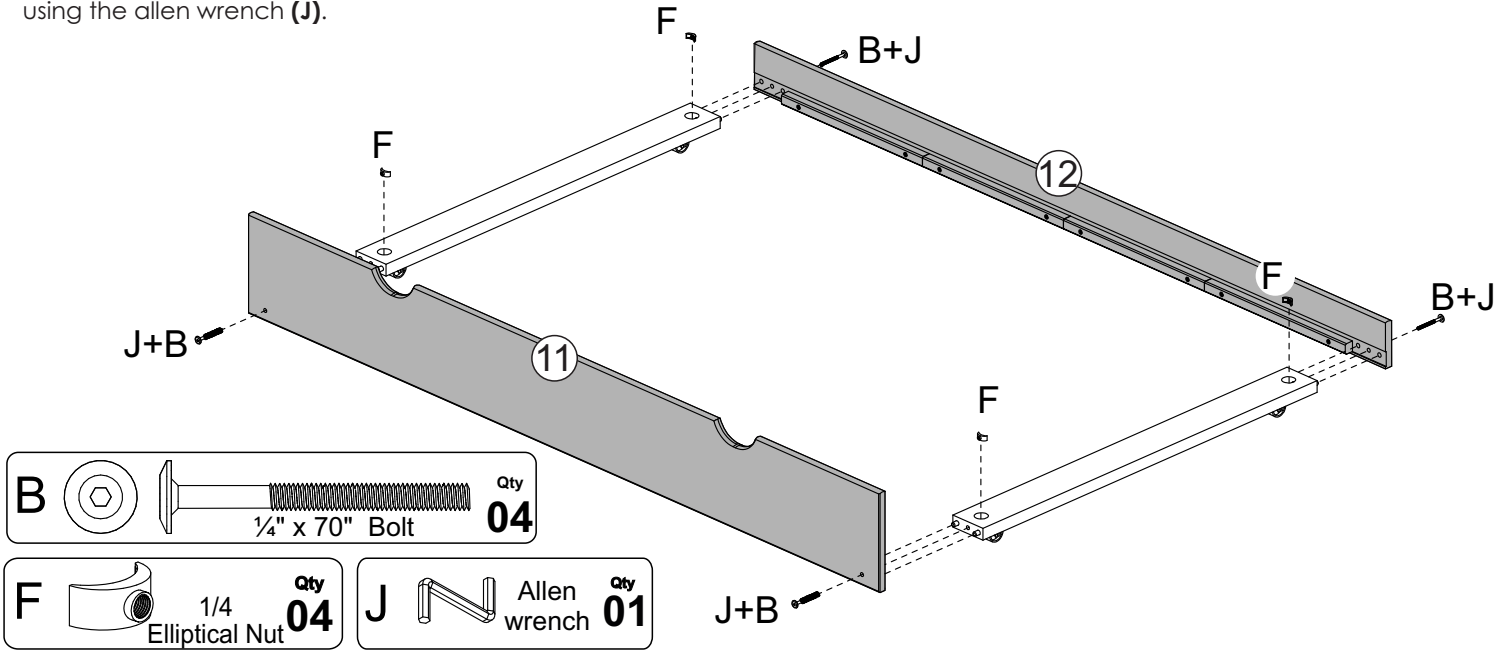

Step 12

Slats

- 1) Attach slats 10 on the rails with 24 screws (G);
- 2) Attach the first slat using the wooden spacer (K), as shown in the diagram.

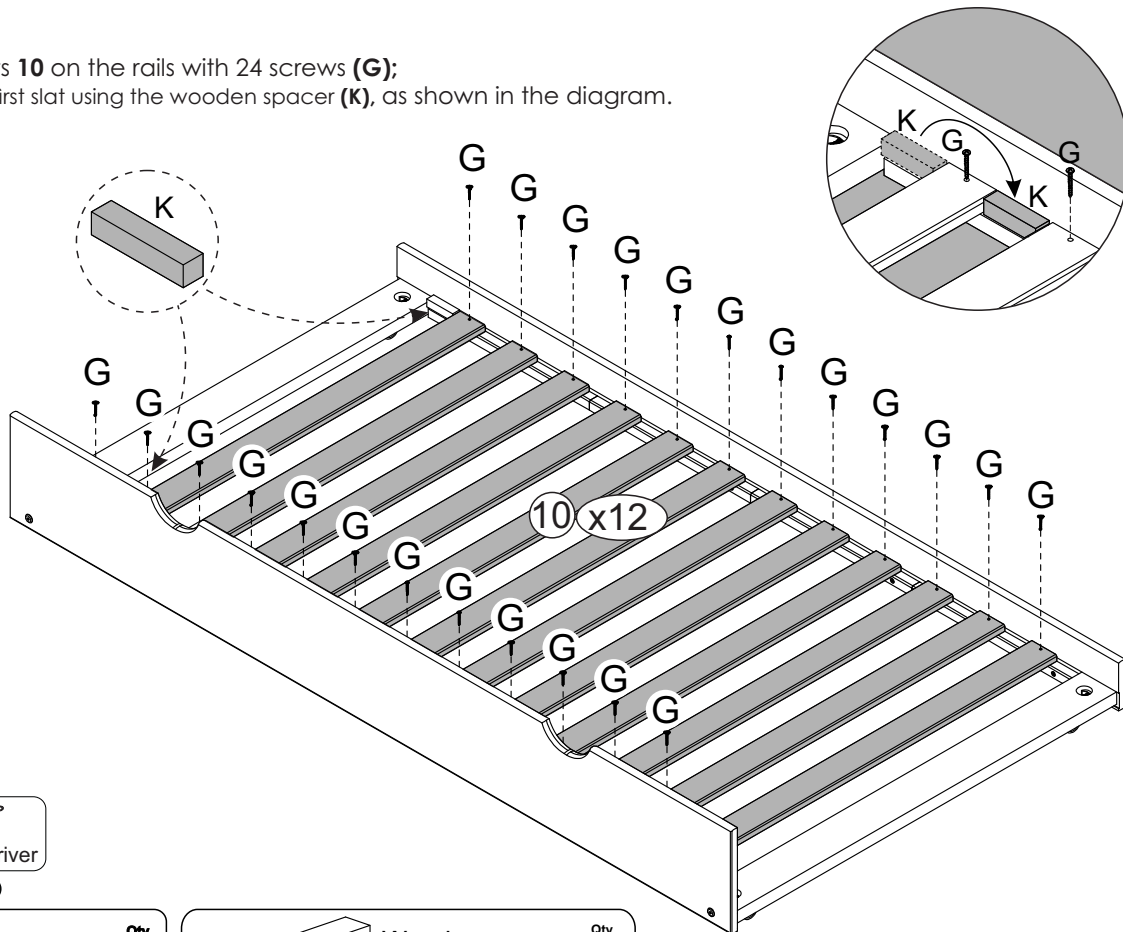

Philips screwdriver
(Not included)

CARE AND MAINTENANCE:

MAINTENANCE:

- Our furniture is designed to be low maintenance, however misuse, irregular use, or improper assembly can result in product malfunction. Regularly check the stability. If pieces feel loose or wobbly tighten all screws immediately.
- To store, review Assembly Instructions and reverse the steps to disassemble.
- Use only provided hardware to assemble and maintain assembly.

CARE:

- To clean use a soft, lint free rag similar to a cloth diaper and wipe away dust regularly. If necessary dampen cloth slightly with warm water and gently rub away spots. Dry thoroughly.
 - Do not use a bleach solution.
 - Do not submerge or allow to lie in standing water.
 - Do not use a sponge or harsh abrasive.
 - Do not use all purpose cleaners or harsh detergents.
 - Do not use Pine Oil cleaners or abrasive household cleaners.
 - Do not use heat or hot water.

ABOUT WOOD AND FINISH:

This product has been carefully crafted of MDF, solid pine wood and/or pine veneers. These materials derive from plantations, a renewable and well managed forest, therefore, not endangering the environment. The highest quality standards have been implemented to assure a sturdy and reliable product. Due to the natural variances in the graining of wood, you may notice subtle differences in the shading and tone of the color stain, warp, holes, wood knots and also small cracks. This is not a defect. But rather a result of the natural beauty of the wood itself.

PLEASE REGISTER THIS PRODUCT AT: WWW.PKOLINO.COM/REGISTER

California 93120 compliant for formaldehyde Phase 2 TPC-AQCARB-03

Return Policy:

- For products purchased through our retail partners please contact them for resolution prior to contacting P'kolino.
- At P'kolino it is our commitment to improve play at home with products that are playfully-stylish and functionally-smart. That means, we want you and the child(ren) to love the way our products look and work. If within 10 days of receipt of your product you are not satisfied you may return it for a refund of the merchandise value.
- Our products and packaging have been designed to withstand standard delivery methods, however, please inspect your product upon receipt for damage to the packaging as products damaged during shipping are subject to exchange or refund. If product has been visibly damaged it is recommended that you refuse the delivery by the carrier. Notify us of the shipment rejection and upon receipt of the rejected shipment we will send you a replacement at no charge.
- To return your product, contact the retailer you purchased your product from. For products with visible wear or that are not properly repackaged will incur a restocking fee of 10%. Please follow assembly, use and care instructions carefully as we will not accept returns on products damaged due to improper assembly, altered or modified products, or on items damaged from normal, excessive or unintended use. Return shipping expenses, unless otherwise specifically stated by P'kolino, will be the customer's expense.
- If you have questions regarding our policy please contact us at customercare@pkolino.com or 888-403-8992.

Warranty:

- P'kolino products are guaranteed to be free from defects in material and workmanship under normal and intended use for a period of 30 days from the date of your purchase.

Replacement/Credit:

- If our product fails to meet our warranty during the warranty period, we will, at our option, replace the product or provide you with a replacement of comparable value.

What Our Limited Warranty Does Not Cover:

- We offer this limited warranty only when the product is used by the original end-user customer. We offer no other warranty. Additionally, while our warranty is excellent, there are other limits to it. We offer NO WARRANTY in cases of damage in transit, inadequate care, abuse, abnormal use, misuse, accidents, normal wear and tear, damage due to environmental or natural elements, failure to follow product instructions, immersion in water (except for products specifically identified by us in writing as intended for water use), or improper storage or maintenance of the products.

Limitation on Damages:

- IN NO EVENT SHALL P'KOLINO, LLC BE LIABLE FOR INCIDENTAL, COMPENSATORY, PUNITIVE, CONSEQUENTIAL, INDIRECT, SPECIAL OR OTHER DAMAGES. OUR AGGREGATE LIABILITY WITH RESPECT TO DEFECTIVE PRODUCTS IS LIMITED TO THE MONIES PAID TO US FOR THE DEFECTIVE GOOD.

Some states and countries do not allow the exclusion or limitation of incidental, consequential or other damages, so the above limitation or exclusion may not apply to you. This warranty gives you specific legal rights, and you may also have other rights which vary based on state, province or country.

Contact Information

Please feel free to contact us at the address listed below

P'kolino LLC • 7300 NW 35th Avenue • Miami, FL 33147 • USA