

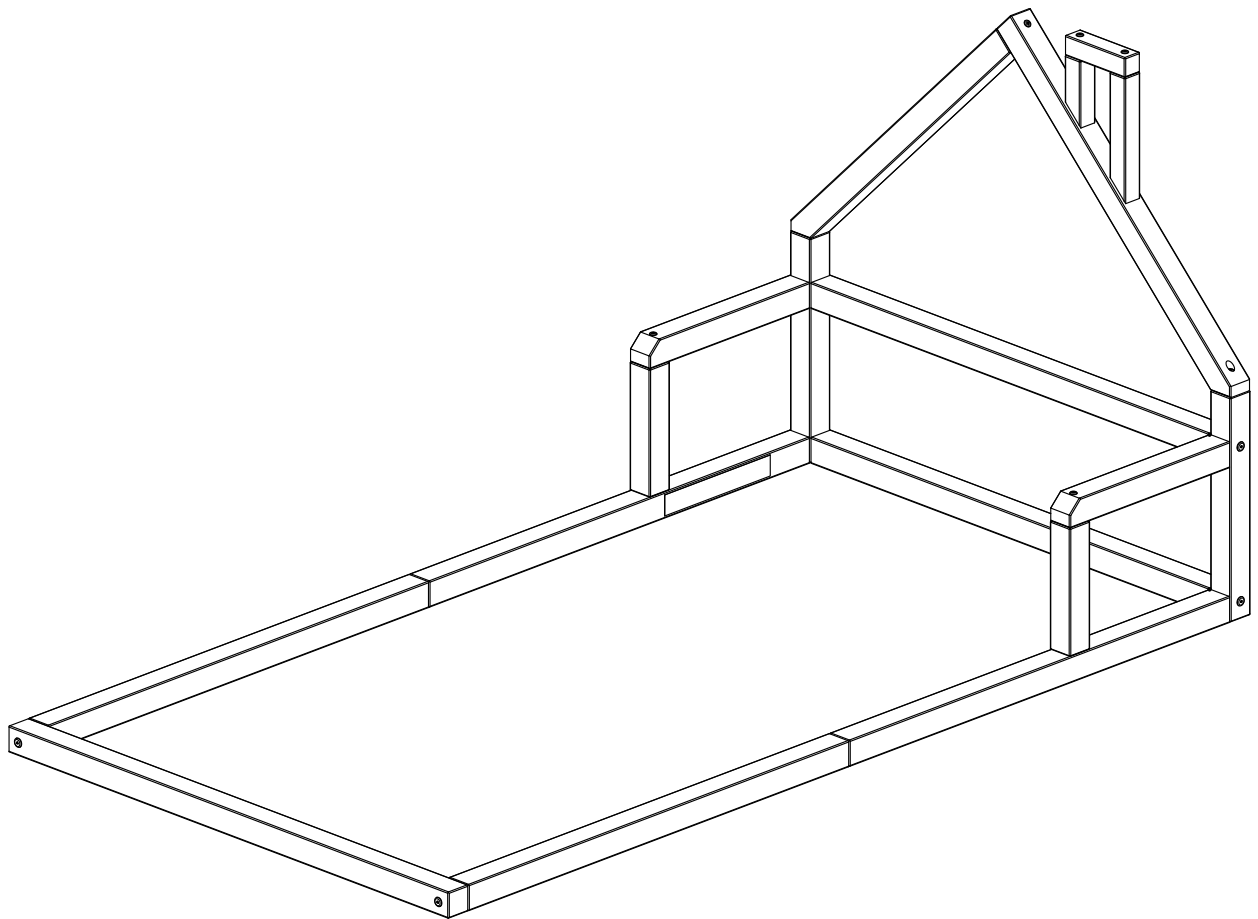

Casita House Floor Bed - Twin



**READ ALL INSTRUCTIONS BEFORE ASSEMBLING TWIN BED.
KEEP INSTRUCTIONS FOR FUTURE USE.
THE ASSEMBLY OF THIS PRODUCT REQUIRES ONE ADULT.**

P'kolino products meet or exceed US, EU, and Canadian safety standards. REG. NO. PA-27620 (CN)
P'kolino (pee-ko-lee-no) © 2022 P'kolino, LLC. All Rights Reserved. All New Materials: Pine Wood. FSC certified. Non toxic and VOC free finish. Made in Brazil.
Questions or comments? Please email: customer-care@pkolino.com Or write to: P'kolino Studio • 7300 NW 35th Ave • Miami, FL 33147, USA. August / 2022



WARNING:

ADULT ASSEMBLY REQUIRED.

Product must be assembled by an adult before use.

After assembly has been completed, all remaining materials and packages are to be recycled according to the regulations in force and kept out of children's reach. Components left after the assembly are not intended for play.

Failure to follow these warnings and the assembly instructions could result in serious injury or death.

Twin bed is intended for home use, not to be used in public institutions. (hospitals, daycares, etc.)



WARNING:

California Proposition 65

This product can expose you to chemicals including wood dust, which is known to the State of California to cause cancer and birth defects or other reproductive harm. For more information, go to www.p65warnings.ca.gov.

This Box Contains:

Casita House Floor Bed - Twin Parts:

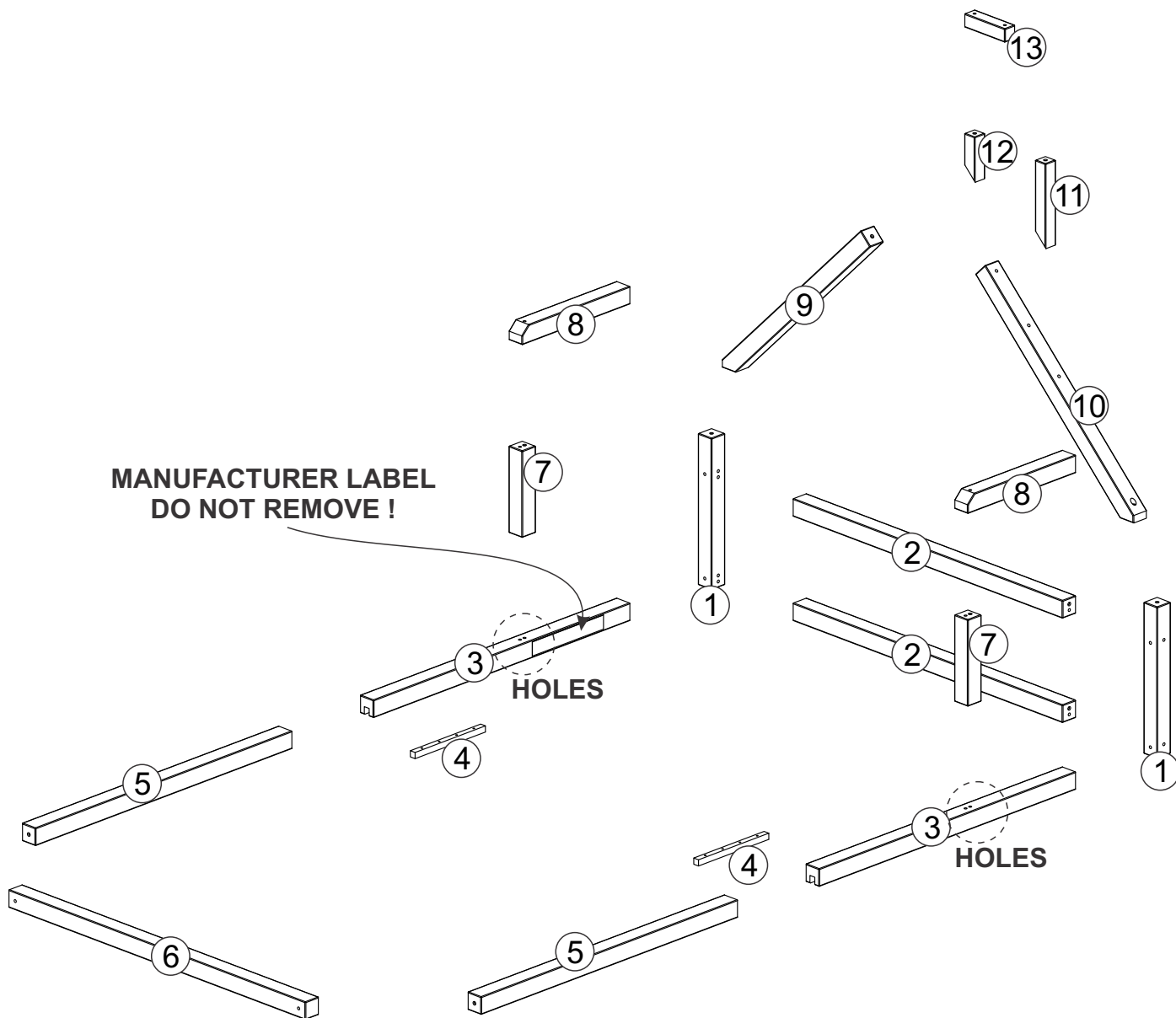

Tools required

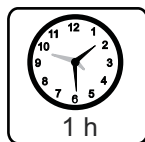
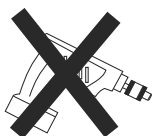
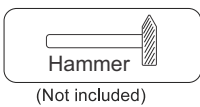
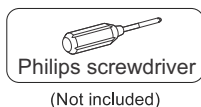

You will need a Phillips head screwdriver and a hammer

P'kolino products meet or exceed US, EU, and Canadian safety standards. REG. NO. PA-27620 (CN)
P'kolino (pee-ko-lee-no) © 2022 P'kolino, LLC. All Rights Reserved. All New Materials: Pine Wood. FSC certified. Non toxic and VOC free finish. Made in Brazil.
Questions or comments? Please email: customercare@pkolino.com Or write to: P'kolino Studio • 7300 NW 35th Ave • Miami, FL 33147, USA. August / 2022

Identify the size and type of hardware using the illustration below:

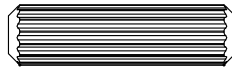

08 - Wooden dowels
1 $\frac{3}{16}$ " (8 x 30mm) (A)

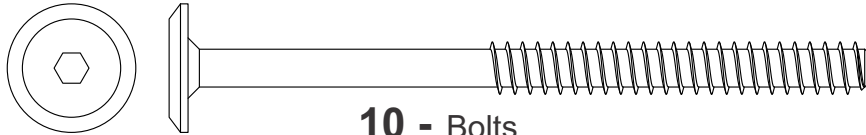

10 - Bolts
3 $\frac{9}{16}$ " (7 x 90mm) (B)

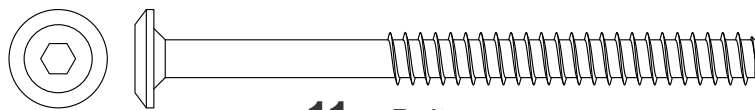

11 - Bolts
3 $\frac{1}{8}$ " (7 x 80mm) (C)

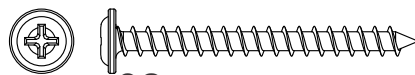

08 - Screws
1 $\frac{9}{16}$ " (4 x 40mm) (D)

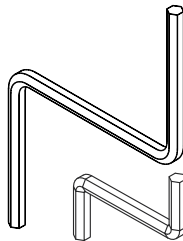

02 - Allen wrench (E)

FOR MISSING PARTS OR HARDWARE:

DO NOT CONTACT THE STORE WHERE YOU MADE YOUR PURCHASE.

Please contact the manufacturer directly at customercare@pkolino.com or 888-403-8992.
For customer service cases involving hardware please provide the part number.

Assembly Instructions

Step 1

Headboard

Insert 4 wooden dowels (A) into the holes, as shown in the diagram.

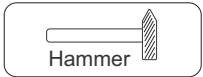
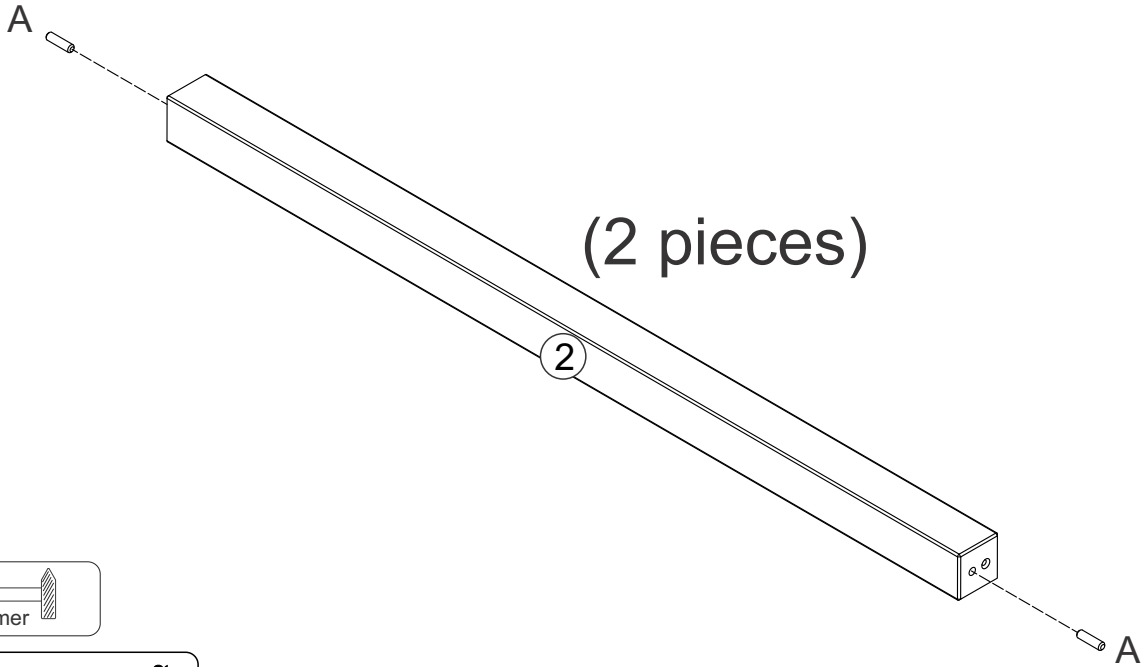

Step 2

Headboard

Attach parts 2 on to part 1, with 2 bolts (B) using 1 Allen wrench (E).

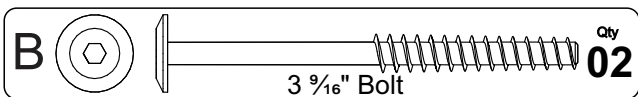
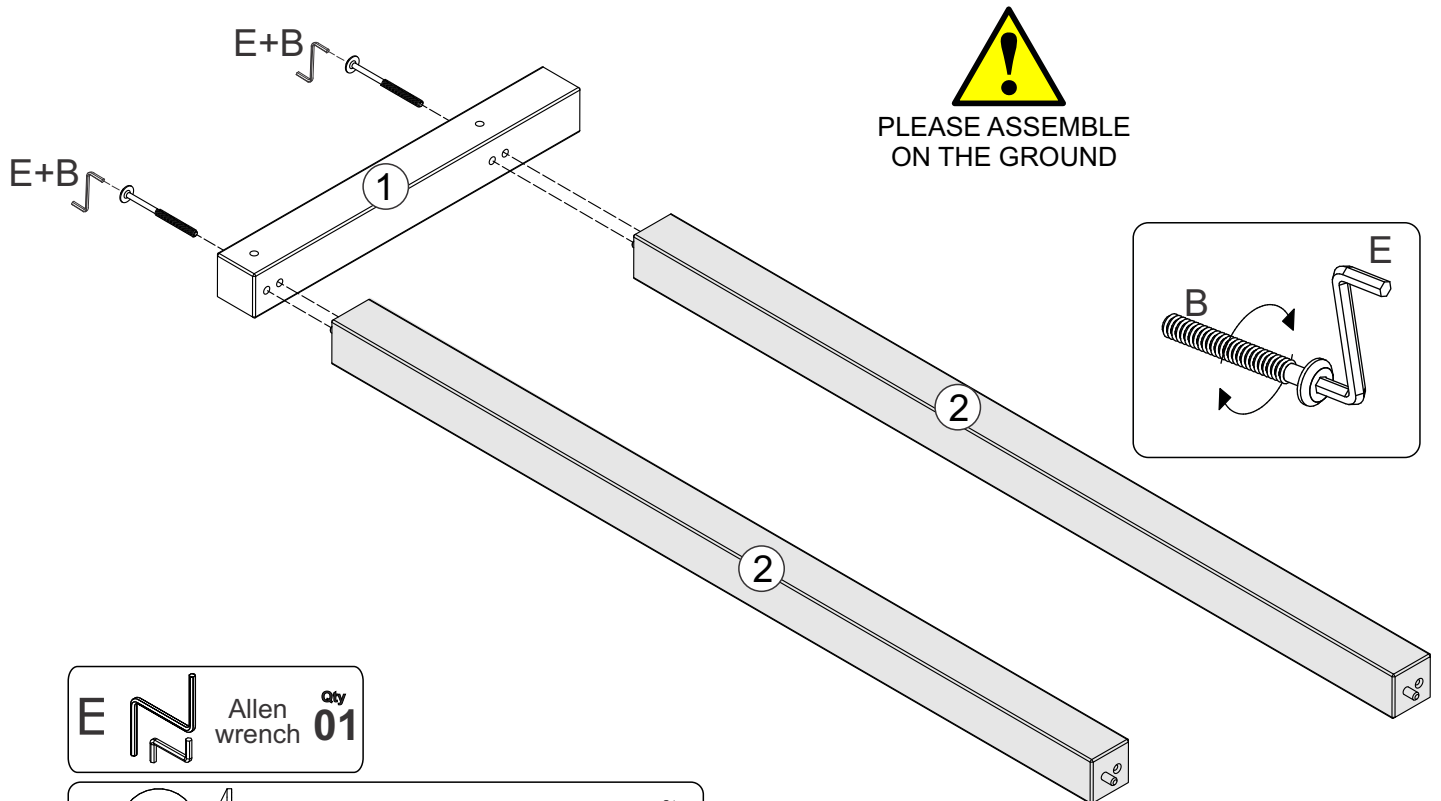

Assembly Instructions

Step 3

Headboard

Attach part 1 on to parts 2 with 2 bolts (B), using 1 Allen wrench (E).

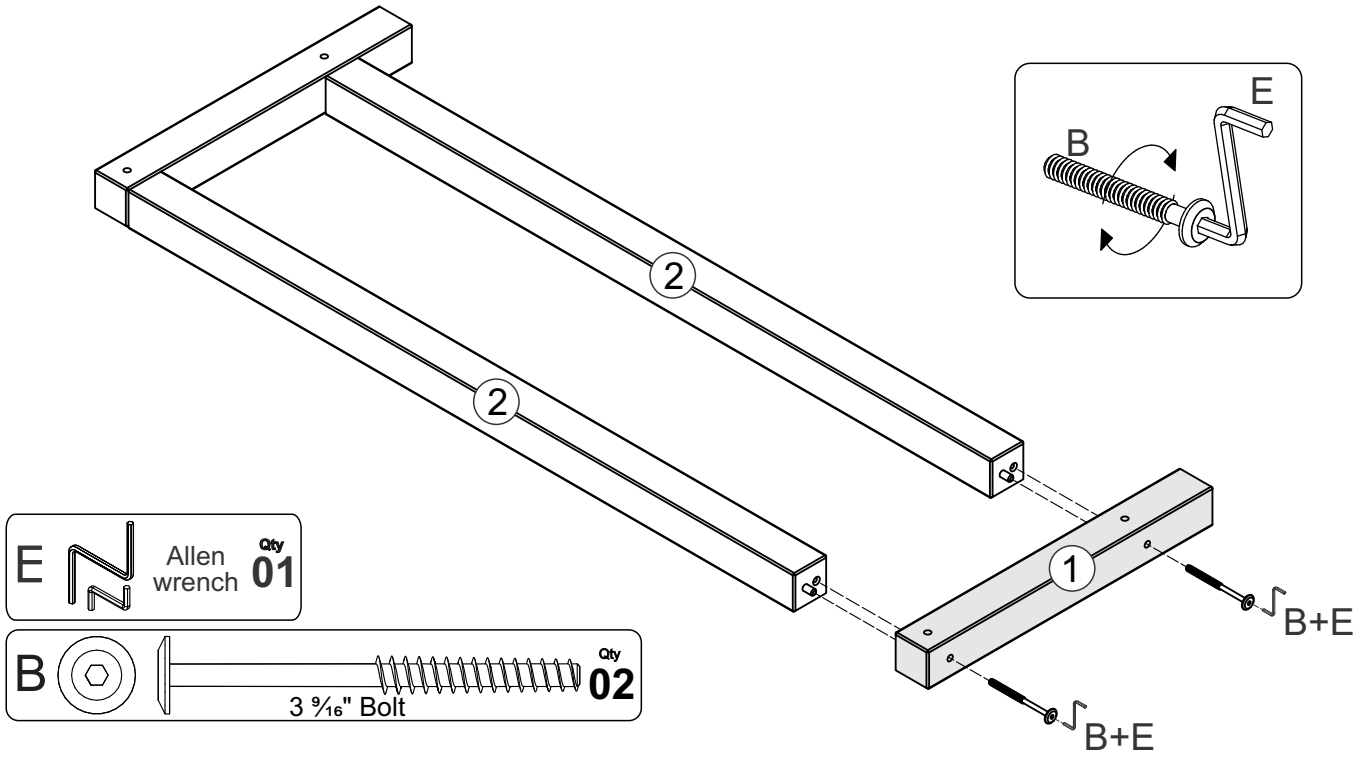

Step 4

Headboard

Attach part 9 on to part 10 with 1 bolt (C), using 1 Allen wrench (E).

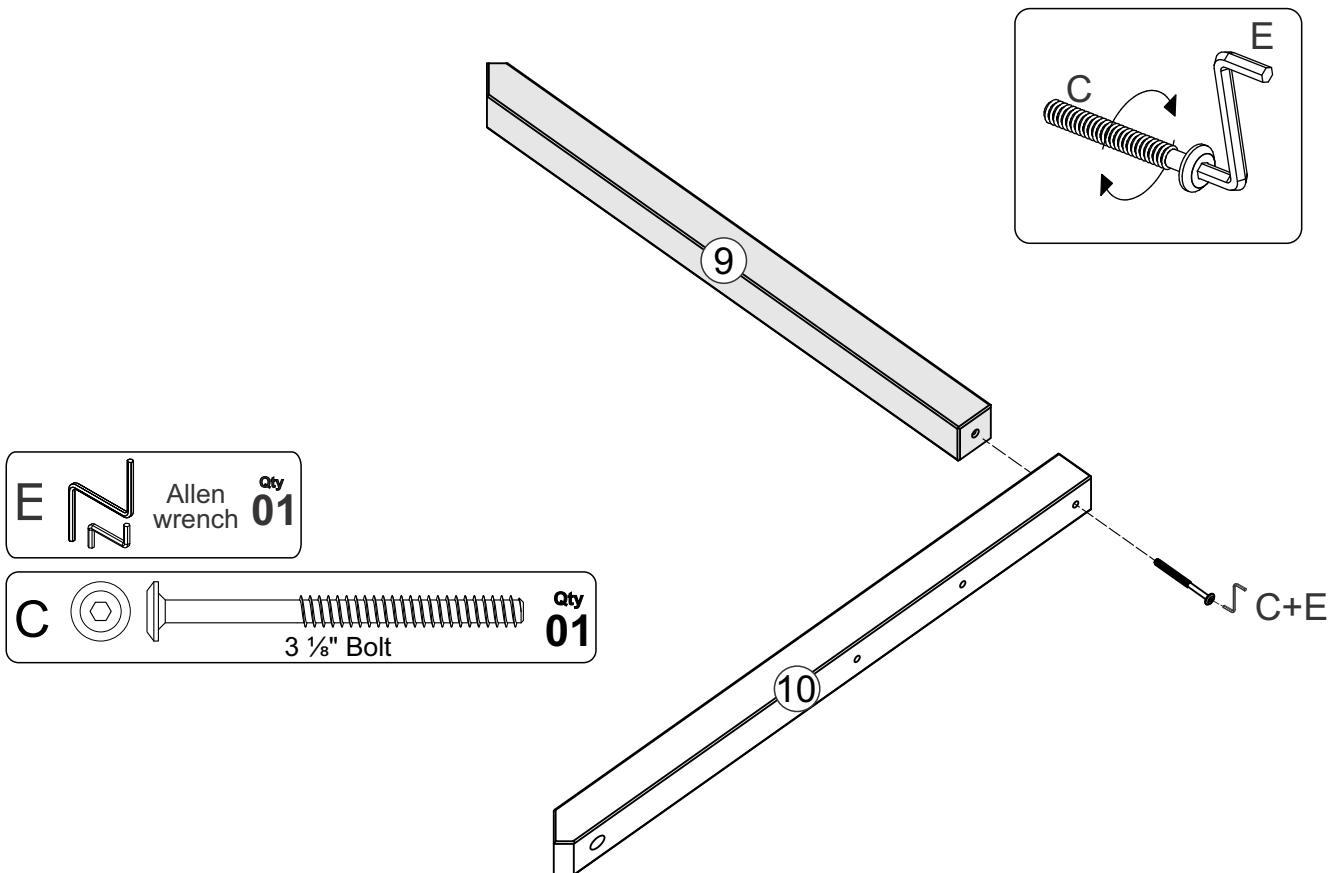

Assembly Instructions

Step 5

Headboard

Attach parts 9 and 10 on to parts 1 with 2 bolts (C), using 1 Allen wrench (E).



PLEASE ASSEMBLE
ON THE GROUND

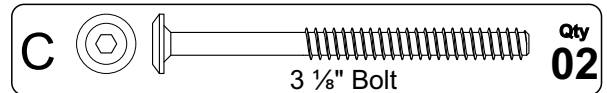
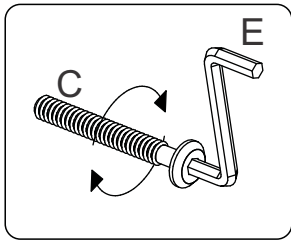
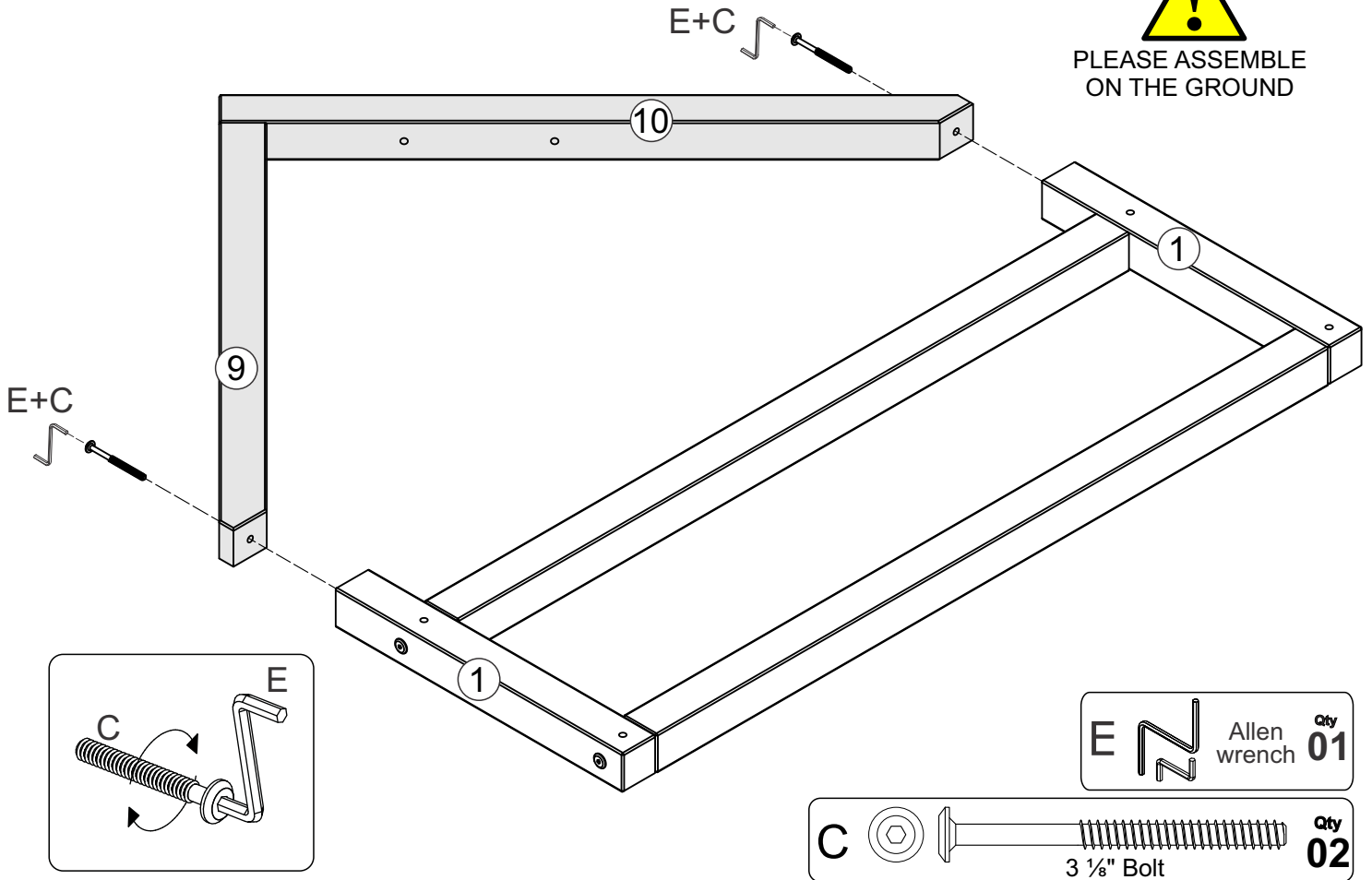

Step 6

Headboard

Attach parts 11 and 12 on to part 13 with 2 bolts (C), using 1 Allen wrench (E).

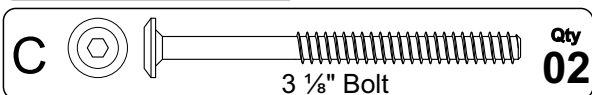
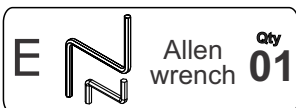
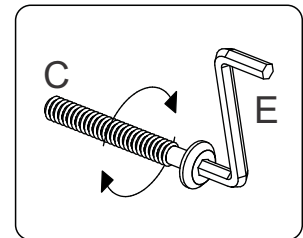
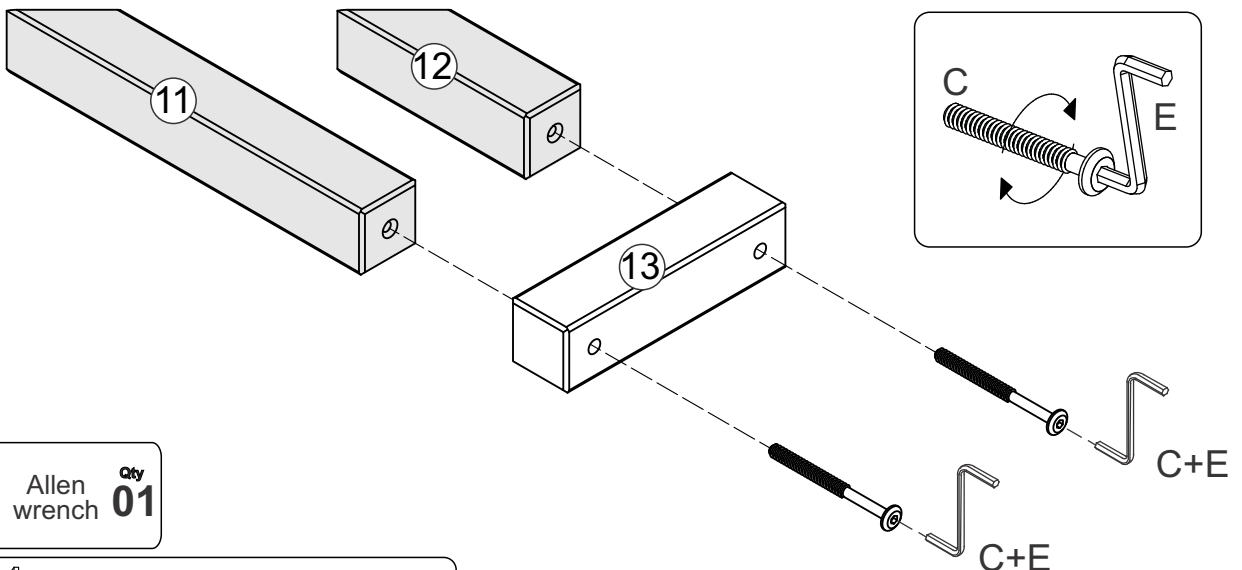

Assembly Instructions

Step 7

Headboard

Attach parts 11 and 12 on to part 10 with 2 bolts (C), using 1 Allen wrench (E).

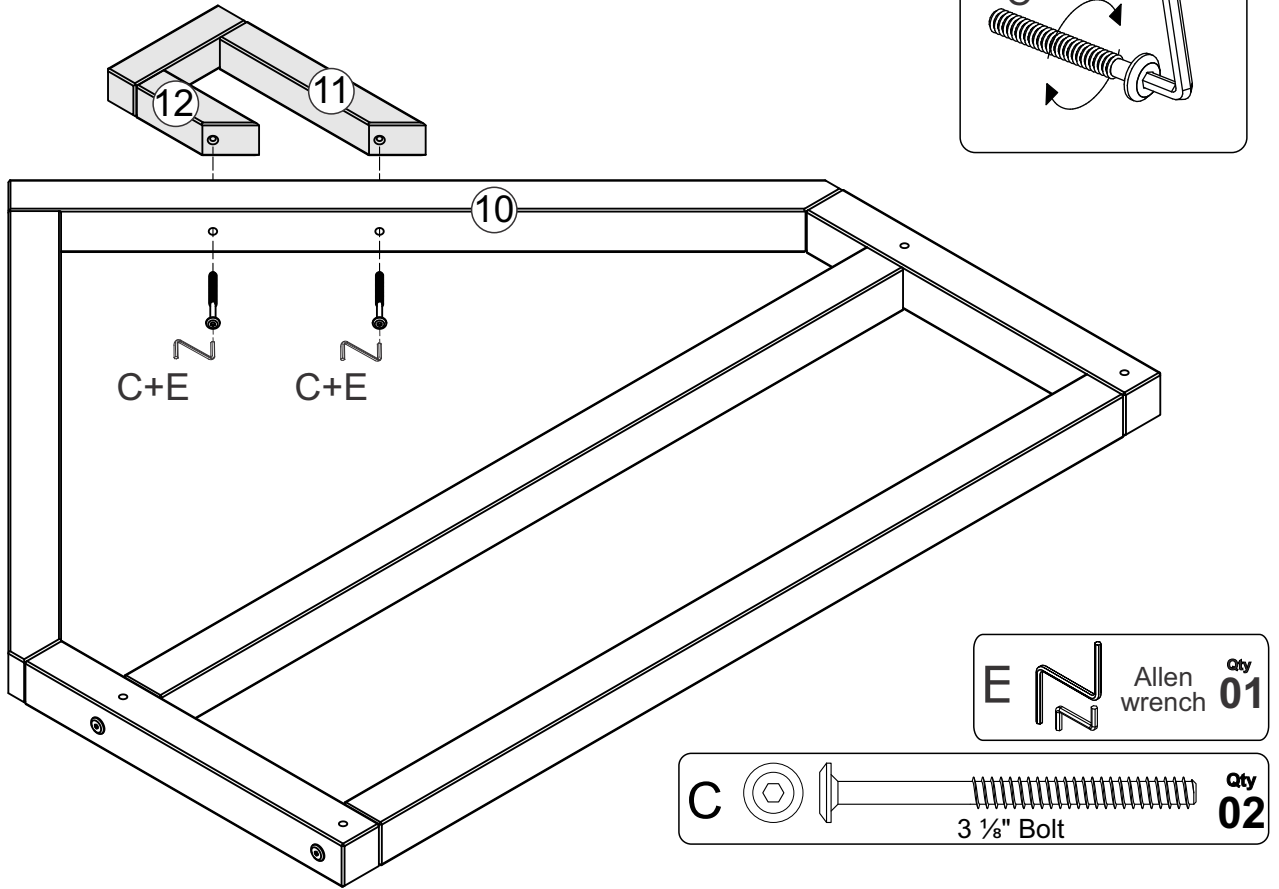

Step 8

Siderails

- 1) Join parts 3 and 5, and insert the cleat 4 into the space.
- 2) Attach the cleat 4 with 4 screws (D), using 1 Philips Screwdriver. Repeat this step 2 times.

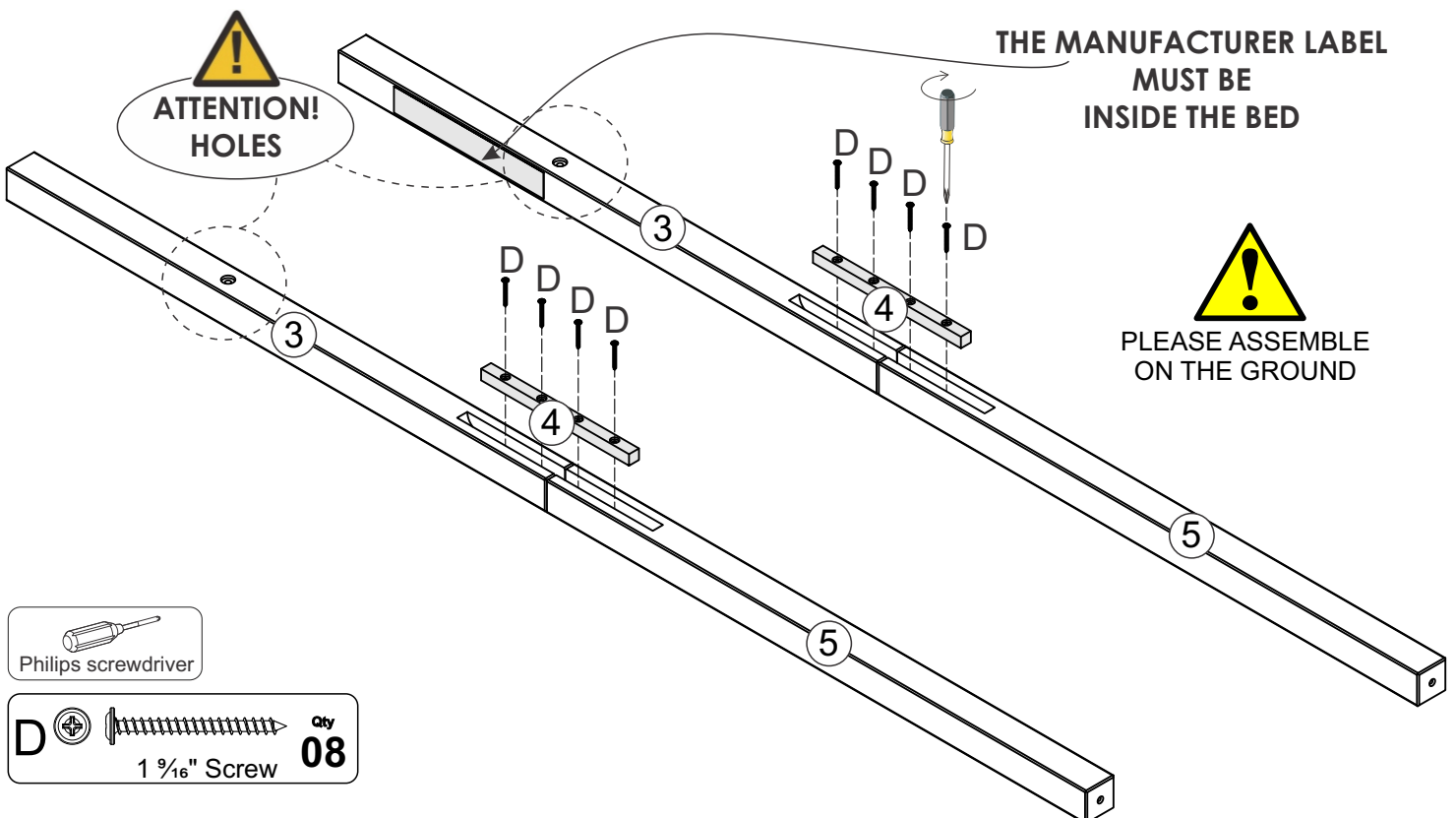

Assembly Instructions

Step 9

Siderails

Insert 4 wooden dowels (A) into the holes, as shown in diagram.

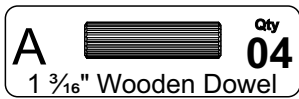
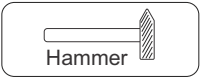
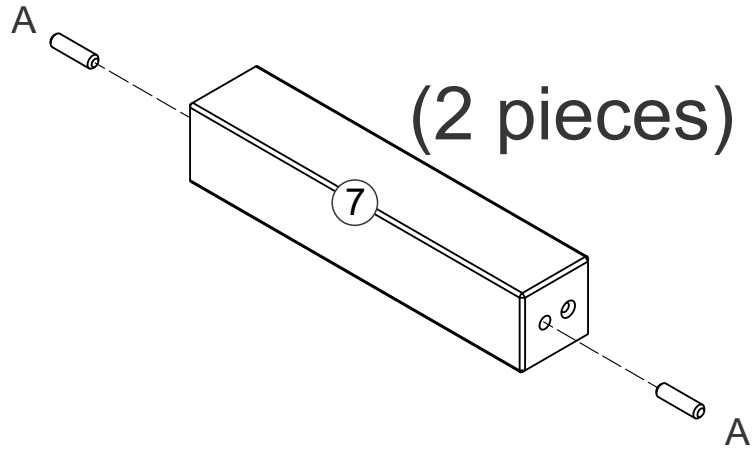

Step 10

Siderails

Attach parts 8 on to parts 7 with 2 bolts (C), using 1 Allen wrench (E). Repeat this step 2 times.

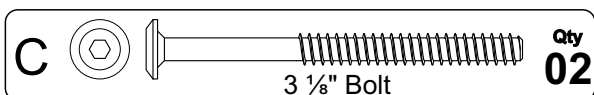
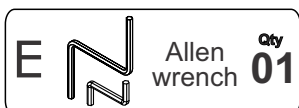
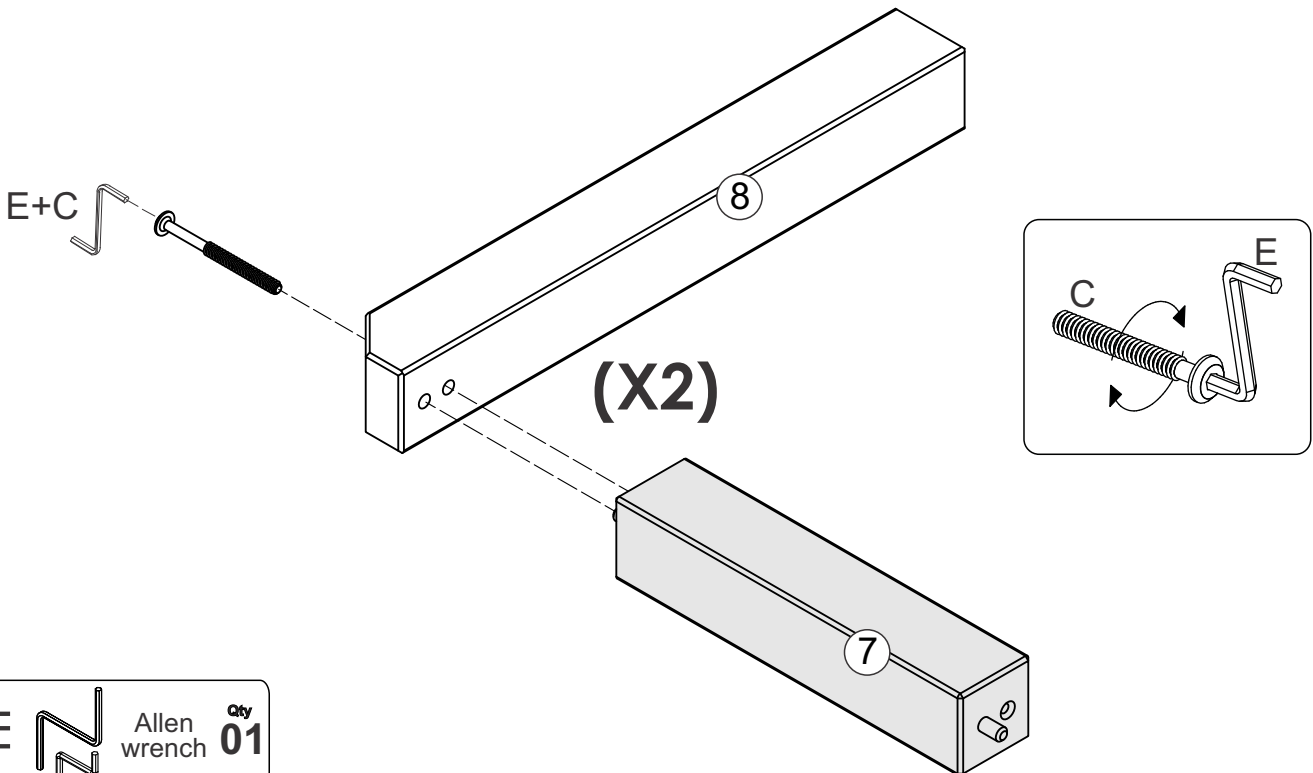

Assembly Instructions

Step 11

Siderails

Attach parts **7** on to parts **3** with 1 bolt (**C**), using 1 Allen wrench (**E**). Repeat this step 2 times.

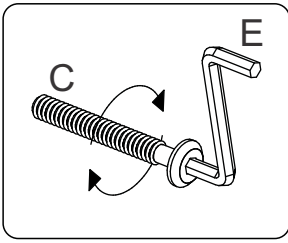

THE MANUFACTURER LABEL MUST BE
INSIDE THE BED

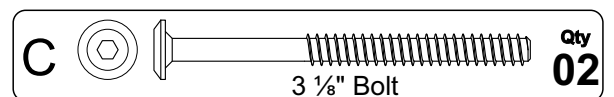
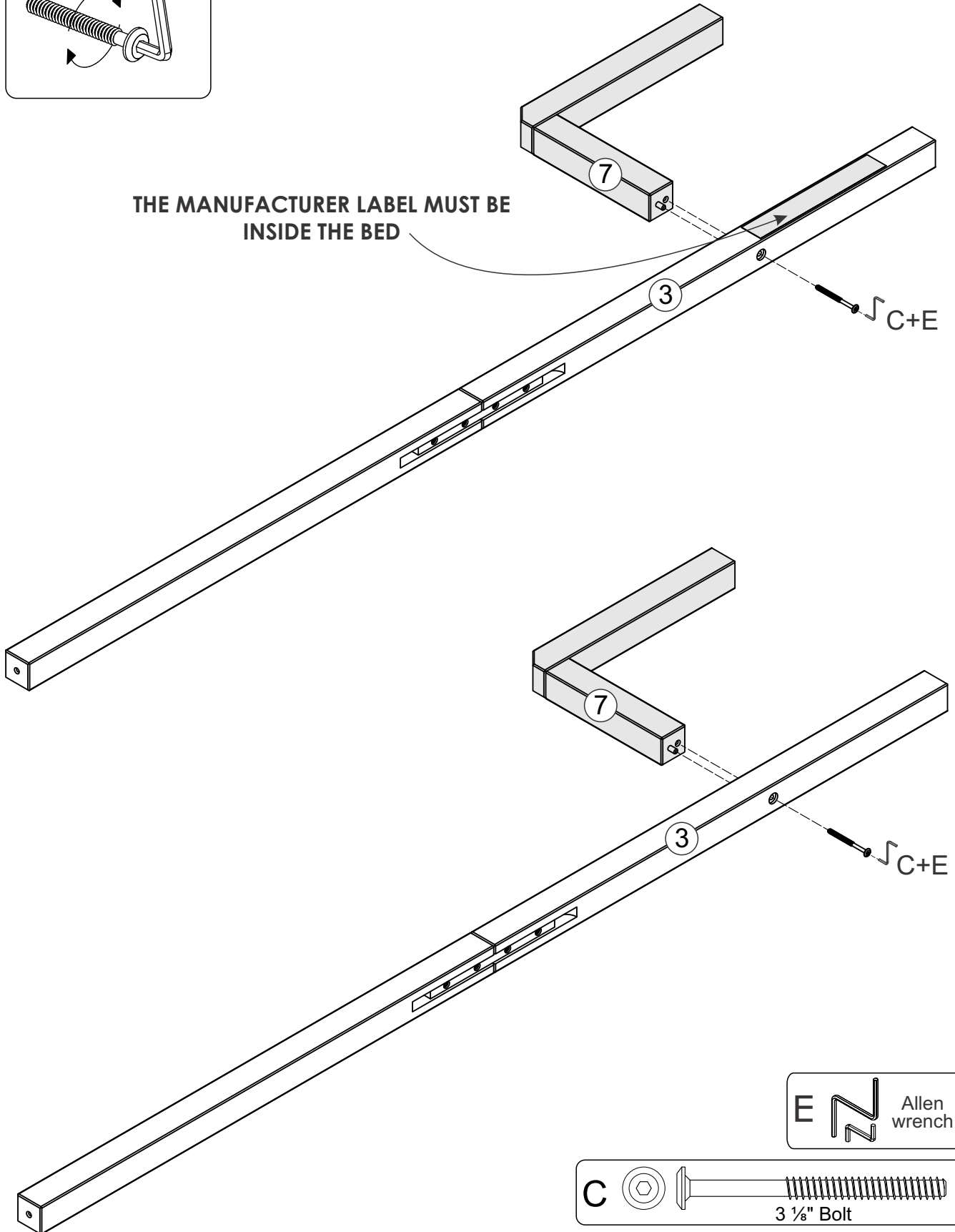

Assembly Instructions

Step 12

Siderails

Attach siderails on the headboard with 2 bolts (B), using 1 Allen wrench (E).



ATTENTION:

This step you can choose which side the chimney will be assembled, on the right or on the left side.

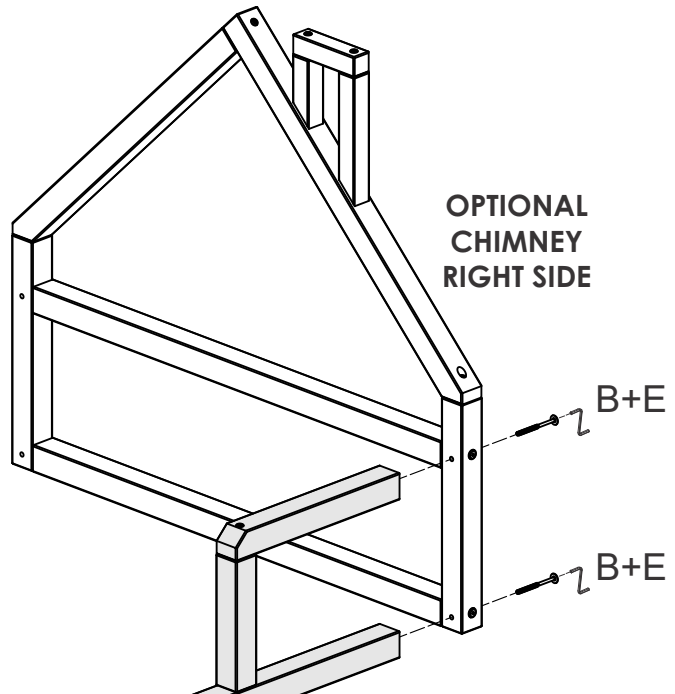

OPTIONAL CHIMNEY LEFT SIDE

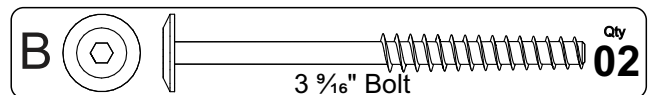
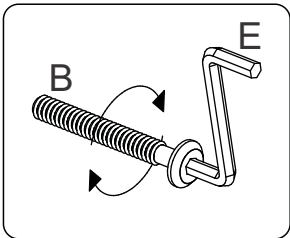
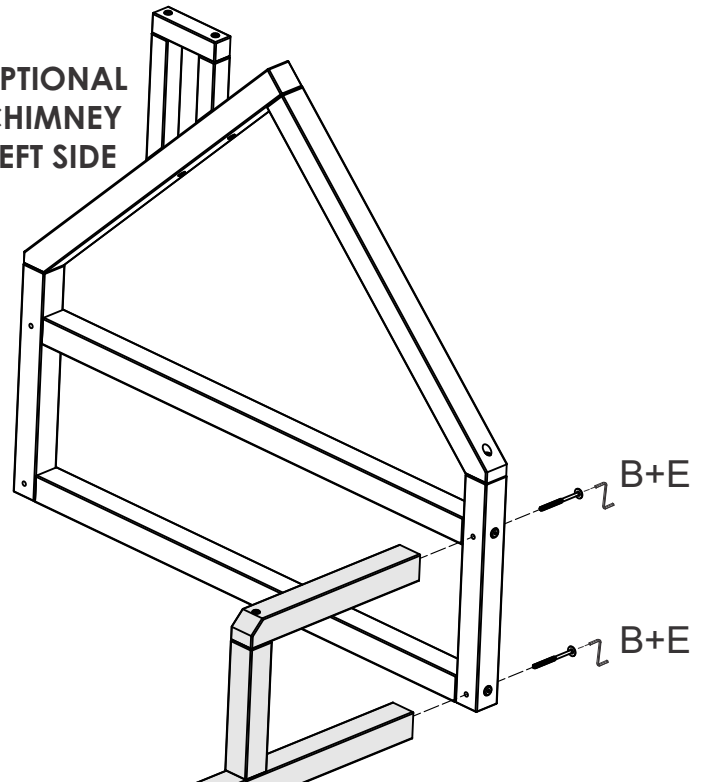

Assembly Instructions

Step 13

Siderails

Attach the other siderail on the headboard with 2 bolts (B), using 1 Allen wrench (E).

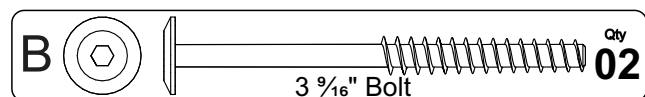
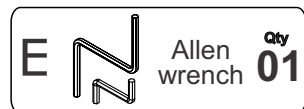
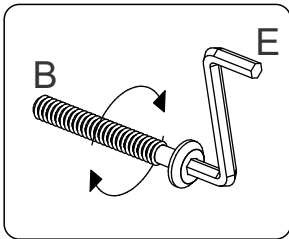
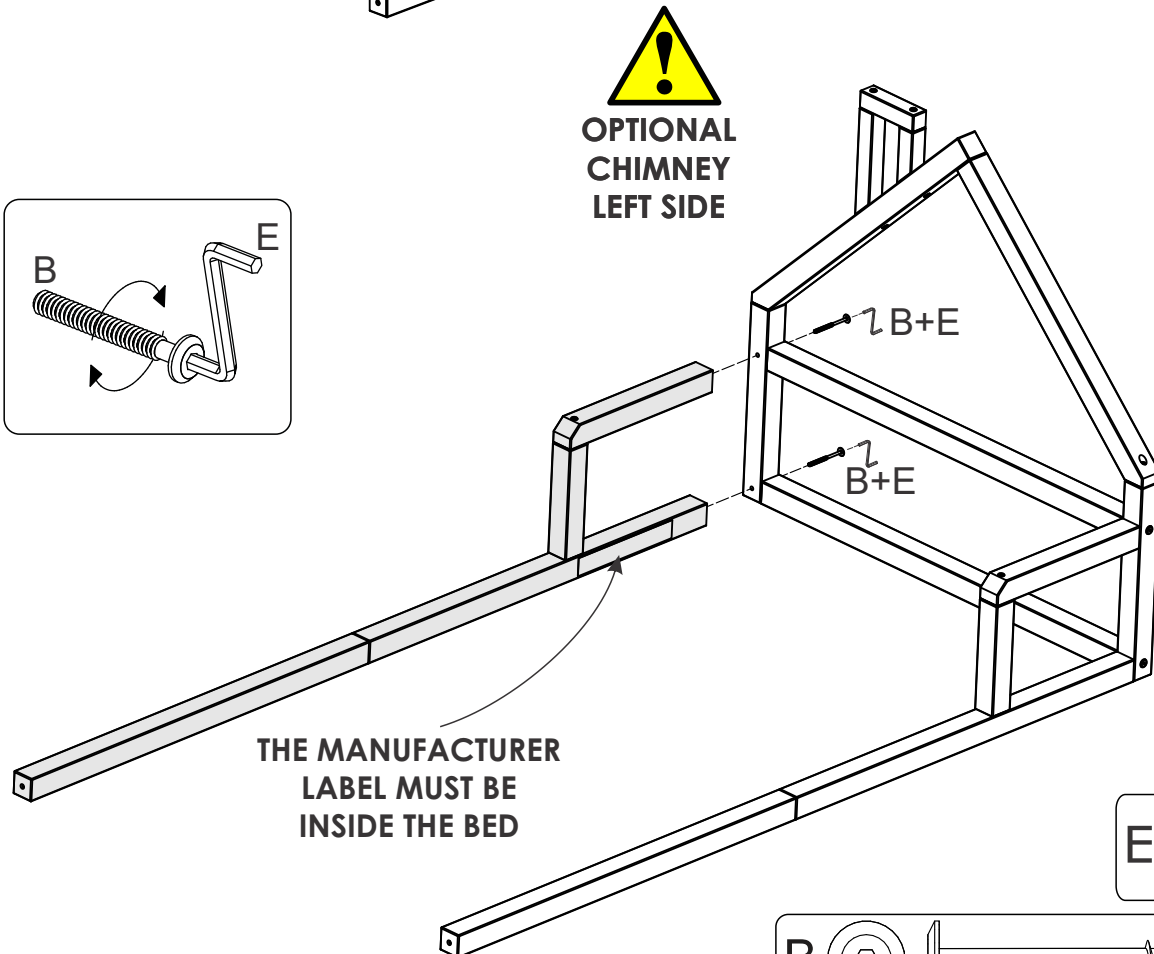
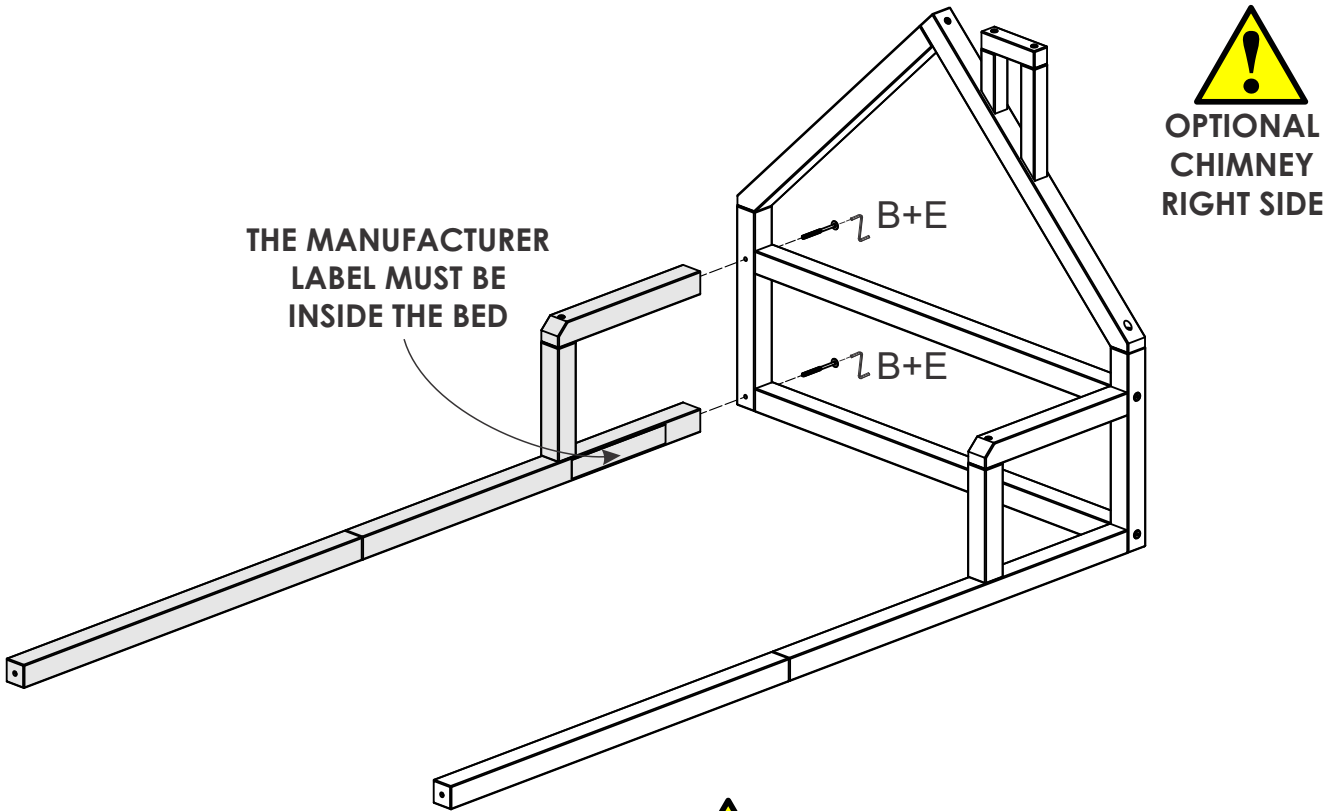

Assembly Instructions

Step 14

Footboard

Attach the footboard on the siderail with 2 bolts (B), using 1 Allen wrench (E).



OPTIONAL
CHIMNEY
RIGHT SIDE

THE MANUFACTURER
LABEL MUST BE
INSIDE THE BED

E+B

E+B



OPTIONAL
CHIMNEY
LEFT SIDE

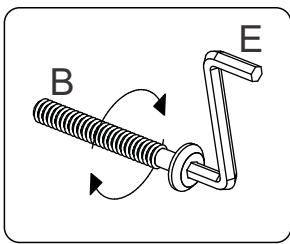

THE MANUFACTURER
LABEL MUST BE
INSIDE THE BED

E+B

E+B

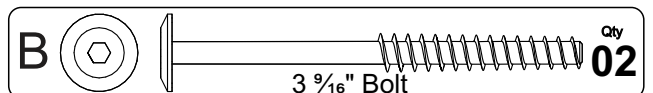

Return Policy:

- For products purchased through our retail partners please contact them for resolution prior to contacting P'kolino.
- At P'kolino it is our commitment to improve play at home with products that are playfully-stylish and functionally-smart. That means, we want you and the child(ren) to love the way our products look and work. If within 10 days of receipt or your product you are not satisfied you may return it for a refund of the merchandise value.
- Our products and packaging have been designed to withstand standard delivery methods, however, please inspect your product upon receipt for damage to the packaging as products damaged during shipping are subject to exchange or refund. If product has been visibly damaged it is recommended that you refuse the delivery by the carrier. Notify us of the shipment rejection and upon receipt of the rejected shipment we will send you a replacement at no charge.
- To return your product, contact the retailer your purchased your product from. For products with visible wear or that are not properly repackaged will incur a restocking fee of 10%. Please follow assembly, use and care instructions carefully as we will not accept returns on products damaged due to improper assembly, altered or modified products, or on items damaged from normal, excessive or unintended use. Return shipping expenses, unless otherwise specifically stated by P'kolino, will be the customers expense.
- If you have questions regarding our policy please contact us at customercare@pkolino.com or 888-403-8992.

Warranty:

- P'kolino products are guaranteed to be free from defects in material and workmanship under normal and intended use for a period of 30 days from the date of your purchase.

Replacement/Credit:

- If our product fails to meet our warranty during the warranty period, we will, at our option, replace the product or provide you with a replacement of comparable value.

What Our Limited Warranty Does Not Cover:

- We offer this limited warranty only when the product is used by the original end-user customer. We offer no other warranty. Additionally, while our warranty is excellent, there are other limits to it. We offer NO WARRANTY in cases of damage in transit, inadequate care, abuse, abnormal use, misuse, accidents, normal wear and tear, damage due to environmental or natural elements, failure to follow product instructions, immersion in water (except for products specifically identified by us in writing as intended for water use), or improper storage or maintenance of the products.

Limitation on Damages:

- IN NO EVENT SHALL P'KOLINO, LLC BE LIABLE FOR INCIDENTAL, COMPENSATORY, PUNITIVE, CONSEQUENTIAL, INDIRECT, SPECIAL OR OTHER DAMAGES. OUR AGGREGATE LIABILITY WITH RESPECT TO DEFECTIVE PRODUCTS IS LIMITED TO THE MONIES PAID TO US FOR THE DEFECTIVE GOOD.

Some states and countries do not allow the exclusion or limitation of incidental, consequential or other damages, so the above limitation or exclusion may not apply to you. This warranty gives you specific legal rights, and you may also have other rights which vary based on state, province or country.

Contact Information

Please feel free to contact us at the address listed below

P'kolino LLC • 7300 NW 35th Avenue • Miami, FL 33147 • USA

CARE AND MAINTENANCE:

MAINTENANCE:

- Our furniture is designed to be low maintenance, however misuse, irregular use, or improper assembly can result in product malfunction. Regularly check the stability. If pieces feel loose or wobbly tighten all screws immediately.
- To store, review Assembly Instructions and reverse the steps to disassemble.
- Use only provided hardware to assemble and maintain assembly.

CARE:

- To clean use a soft, lint free rag similar to a cloth diaper and wipe away dust regularly. If necessary dampen cloth slightly with warm water and gently rub away spots. Dry thoroughly.
 - Do not use a bleach solution.
 - Do not submerge or allow to lie in standing water.
 - Do not use a sponge or harsh abrasive.
 - Do not use all purpose cleaners or harsh detergents.
 - Do not use Pine Oil cleaners or abrasive household cleaners.
 - Do not use heat or hot water.

ABOUT WOOD AND FINISH:

This product has been carefully crafted of MDF, solid pine wood and/or pine veneers. These materials derive from plantations, a renewable and well managed forest, therefore, not endangering the environment. The highest quality standards have been implemented to assure a sturdy and reliable product. Due to the natural variances in the graining of wood, you may notice subtle differences in the shading and tone of the color stain, warp, holes, wood knots and also small cracks. This is not a defect. But rather a result of the natural beauty of the wood itself.

PLEASE REGISTER THIS PRODUCT AT: WWW.PKOLINO.COM/REGISTER

California 93120 compliant for formaldehyde Phase 2 TPC-AQCARB-03