



# DORNIER Do 217

## ASSEMBLY MANUAL

SIGRC99



**SIG MANUFACTURING COMPANY, INC.**

### Introduction

The following is a little history of the original development of this unique and handsome aircraft. The Dornier Do 217 was a later development of the original Do 17 series of bombers and reconnaissance aircraft. The prototype Do 17 first flew in 1938 and was not especially successful. Never-the-less development continued and early pre-production Do 217A-O's undertook a variety of clandestine photo-recon missions over the Soviet Union, prior to the German attack in 1941. Further development of the type produced the E-2 variant, originally conceived as a divebomber. However trials proved this unpractical and the E-2 was ultimately used for bombing raids over Great Britain and for antishipping missions over the North Sea and the Atlantic.

The Do 217J-1 variant was developed and used as a stopgap night fighter to counter the increasing number of bomber raids over Germany in 1942. Modified from the E-2, the J-1 had a solid, non-glazed nose, bristling with four 20mm cannons and four 7.9mm machine guns.

This brings us to Spring 1943, when the Do 217N-2R22 variant went into production as a dedicated and heavily armed night fighter. This aircraft retained the solid nose with the four cannon and four machine guns in place. But in addition, it also carried another four 20mm cannons mounted in the top of fuselage, behind the canopy. These weapons fired upwards at a 70° forward angle. This unusual armament system was used effectively against Allied bomber formations and was called "Schräge Musik". Later versions also included the Lichtenstein SN-2 radar system, with its unique antenna array on the fuselage nose.

The SIG Do 217 is strictly a sport scale model and not necessarily based on any particular variant. Instead, we leaned on both the J-1 and 2R22 night fighter versions of this airplane to create our own R/C version. If you desire, the SIG Do 217 lends itself to a lot of details that would look great on this model.

The recent and rapid development of super-efficient electric motors and certainly lithium polymer batteries have both served to make multi-engine models a very practical reality. Our prototype Do 217 models have proven to be outstanding R/C aircraft, both in terms of performance and looks. We've flown our own prototypes a great deal and can report to you for sure that they are solid flying models with surprisingly honest flying characteristics. When powered with a couple of appropriately sized brushless outrunner motors, swinging the recommended prop sizes, the airplane will have a wide speed range and should be capable of some very nice - although not necessarily scale - aerobatics. While the SIG Do 217 is a comfortable model to fly, we do not recommend it as a first R/C model. But we can and do highly recommend the Do 217 as your first semi-scale twin electric model!

This assembly manual will guide you through each construction phase in detail and is further enhanced with photos that visually assist you with each step. It is important that you follow the construction sequence carefully and accurately to achieve the best results.

## Reference Material

"GERMAN AIRCRAFT of WORLD WAR II", Edited by David Donald, Published by Motorbooks International, Osceola, WI

| <b>Kit Specifications:</b> | <b>Imperial</b>                                     | <b>Metric</b>                 |
|----------------------------|---|-------------------------------|
| Wing Span                  | 47 in.  | 1194 mm                       |
| Wing Area                  | 324.6 sq. in.                                       | 20.9 dm <sup>2</sup>          |
| Length                     | 37.5 in.  | 953 mm                        |
| Flying Weight (typ)        | 30 - 35 oz.   | 850 - 990 g                   |
| Wing Loading               | 14.2 - 16 oz./sq. ft.                               | 43.3 - 48.7 g/dm <sup>2</sup> |
| Motor (2 Required)         | 40 - 70 Watt Motors                                 |                               |
| Radio Equipment            | 4 Channels, (w/Mini Receiver & 3 or 4 Micro Servos) |                               |
| Kit Number                 | SIGRC99   |                               |



## Required Tools & Supplies

- Glues - SIG Kwik-Set 5-Minute Epoxy, SIG-Bond Glue, SIG Thin, Medium and Thick CA Glue
- Loctite® Non-Permanent Thread Locker
- Hobby Knife with Sharp #11 Blades
- SIG AeroKote® or AeroKote-Lite®
- Covering Tools - Heat Gun, Iron, Trim Seal Tool
- Power Drill and hand "pin" vise (for smaller diameter drill bits as needed)
- An assortment of drill bits and/or a numbered drill index
- Soldering Iron and solder - STA-BRITE® Silver Solder suggested
- Building Board
- Modelers "T" pins
- Waxed Paper
- Sandpaper - assorted grits
- Selection of Pliers
- Selection of Screwdrivers
- Razor Blades
- Tweezers

## COMPLETE KIT PARTS LIST

### Balsa Sticks and Sheets

|   |   |   |   |   |   |   |   |
|---|---|---|---|---|---|---|---|
| 5 | 1/16"x3"x36" Balsa sheets for wing sheeting | 4 | 1/16"x2"x36" Balsa sheets for wing sheeting               | 2 | 1/32"x3"x18" Balsa sheet for stabilizer sheeting  | 2 | 1/16"x3/16"x36" Balsa sticks for cap strips |
| 2 | 1/4"x1/2"x24" Shaped balsa leading edge     | 1 | 3/32"x1"x36" Balsa for fuselage                           | 2 | 3/32"x1/4"x36" Balsa stabilizer parts             | 2 | 1/8"x1/4"x36" Balsa for assorted parts      |
| 2 | 1/4"x1/4"x36" Balsa for assorted parts      | 1 | 5/16"x1-1/4"x24" Balsa tapered trailing edge for ailerons | 3 | 1/4"x1-3/4"x1-1/2" Balsa for top front nose block | 1 | 1-3/4"x1-3/4"x1" Balsa for nose block       |
| 1 | 3/4"x1-3/4"x1-1/4" Balsa for tail block     |   |   |   |   |   |   |

### Laser Cut Balsa

|   |                                     |   |                                      |   |                                      |   |                                      |
|---|-------------------------------------|---|--------------------------------------|---|--------------------------------------|---|--------------------------------------|
| 2 | 1/16"x3"x24" Sheet #1 wing ribs     | 1 | 1/16"x3"x24" Sheet #2 assorted parts | 1 | 3/32"x4"x36" Sheet #3 fuselage parts | 2 | 3/32"x3"x36" Sheet #4 fuselage sides |
| 1 | 1/8"x3"x36" Sheet #5 fuselage parts | 1 | 1/8"x3"x24" Sheet #6 fuselage parts  | 1 | 1/8"x3"x24" Sheet #7 assorted parts  | 1 | 1/8"x4"x24" Sheet #8 nacelle parts   |
| 1 | 1/8"x4"x24" Sheet #9 nacelle sides  |   |                                      |   |                                      |   |                                      |

### Laser Cut Plywood - Lite Ply

|   |                                      |   |                                      |  |  |  |  |
|---|--------------------------------------|---|--------------------------------------|--|--|--|--|
| 1 | 1/8"x4"x24" Sheet #10 assorted parts | 1 | 1/8"x6"x16" Sheet #11 assorted parts |  |  |  |  |
|---|--------------------------------------|---|--------------------------------------|--|--|--|--|

### Hardwood Parts

|   |   |   |  |   |  |  |  |
|---|---|---|--|---|--|--|--|
| 6 | 1/8"x3/16"x24" Spruce wing spars and doublers | 1 | 1/8" dia.x4" Dowel for hatch hold down | 1 | 3/16" dia.x2" Dowel for wing hold down |  |  |
|---|---|---|--|---|--|--|--|

### Wire Parts

|   |  |   |  |   |   |   |  |
|---|--|---|--|---|---|---|--|
| 2 | 1/32"x36" Music wire for pushrods                    | 1 | 1/16"x3-1/2" Music wire for control horn | 1 | .027"x6" Steel cable for rudder pushrod | 1 | 30" #20 wire Red electrical cable for motor wiring |
| 1 | 30" #20 wire Black electrical cable for motor wiring |   |  |   |   |   |  |

### Hardware

|   |   |   |  |    |   |   |  |
|---|---|---|--|----|---|---|--|
| 1 | 1/16" I.D. wheel collar Elevator horn     | 5 | 4-40x3/8" headless setscrew Elevator horn & pushrod connectors |    |   |   |  |
| 1 | 4-40 metal threaded RC link Elevator horn | 1 | 10-32 blind nut Wing hold down                                 | 16 | #2x7/16" sheet metal screws, socket head w/washer | 2 | 2-56 metal threaded RC links Aileron linkage |
| 2 | 2-56 threaded steel rods Aileron linkage  | 4 | Pushrod connectors Control hook ups                            |    |   |   |  |

### Miscellaneous Parts

|   |                                       |   |  |   |  |   |   |
|---|---------------------------------------|---|--|---|--|---|---|
| 1 | 1"x24" glass tape Wing center section | 1 | Aileron interconnect horn Elevator pushrod | 1 | Small control horn - right Aileron linkage | 1 | Small control horn - left Aileron linkage     |
| 2 | 1/8"x24" Nylon tubes Pushrod guides   | 1 | 10-32x1" Nylon bolt Wing hold down         | 7 | Easy-hinges Control surfaces               | 1 | 3/32" O.D.x1-1/2" Brass tube Solder couplings |
| 2 | Plastic cowls Vacuum formed ABS       | 1 | Clear canopy Vacuum formed butyrate        | 1 | SIGDKM299 Decal sheet                      | 1 | SIGRPIP299 Instrument Panel                   |
| 1 | Full sized plan                       | 1 | Assembly Manual                            |   |  |   |   |

## Key To Laser-Cut Parts

Use a pencil to identify each of the kit parts according to the following diagrams.

Note: When it is time to remove a part from its sheet, use a sharp #11 blade to slice through the small bridges that hold the part to the sheet. Do not try to push the parts out of the sheet without first cutting through the bridges. Doing so may cause damage to the part.

## Construction Overview

Since the Do-217 kit is a somewhat more complex airplane, compared to typical sport models, the building sequence presented in this manual should help to have the right part at the right time and cut down the time waiting for things to cure. Sort the sheet wood and spars into separate stacks for the right and left wing, stabilizers, nacelles, and fuselage. Doing this ahead of time helps to prevent using a piece of wood in the wrong place and then looking for it later when it is called for. To ease construction where parts are to bend, some of the parts need to be preformed. This is easy to do but takes some time. These instructions will tell you when to do this.

Sheet#5 1/8"x3"x36"  
Balsa (1 Req.)

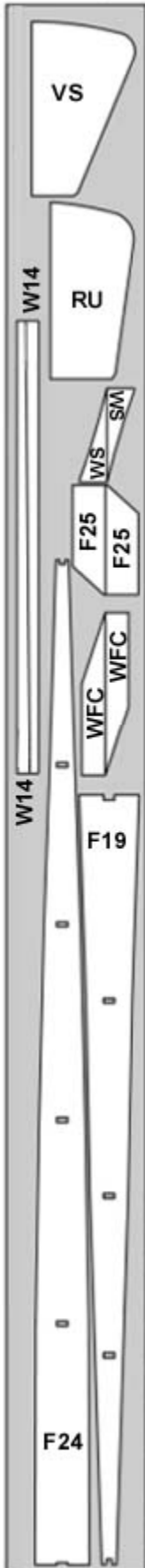

# KEY TO LASER CUT PARTS

Sheet#11 1/8"x6"x16"  
Lite-Ply (1 Req.)

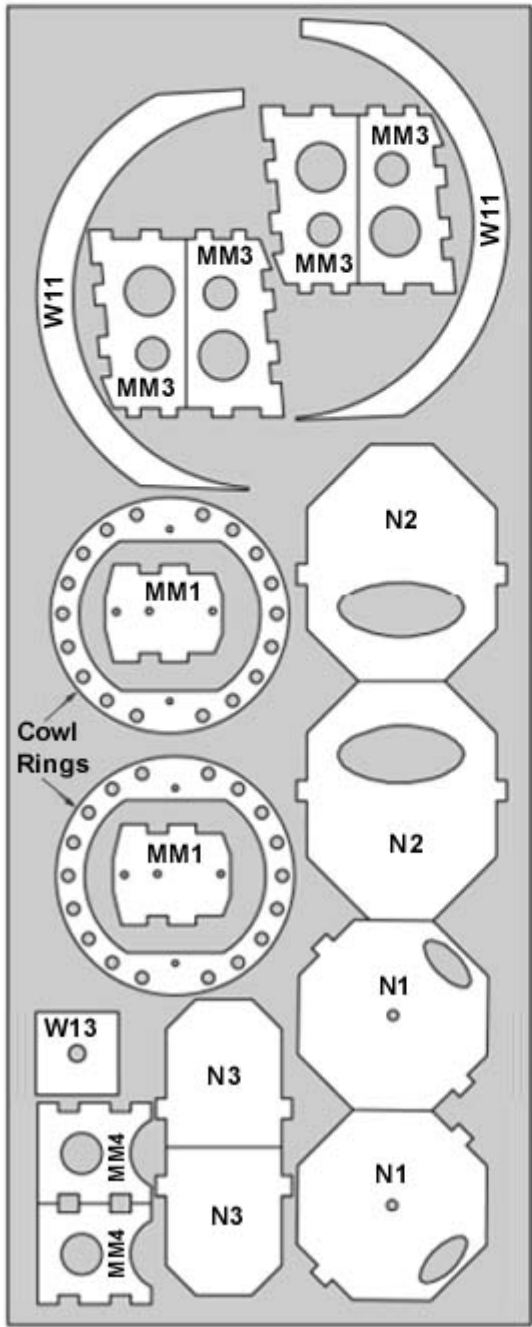

Sheet#10 1/8"x4"x24"  
Lite-Ply (1 Req.)

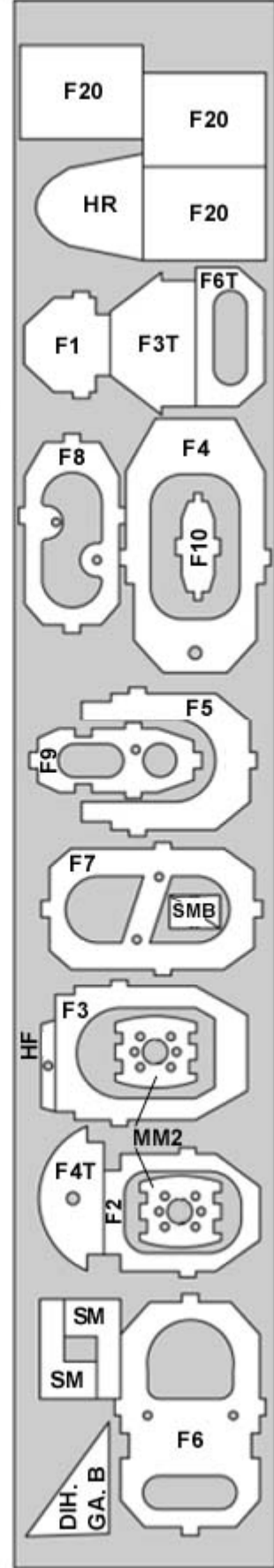

Sheet#4 3/32"x3"x36"  
Balsa (2 Req.)

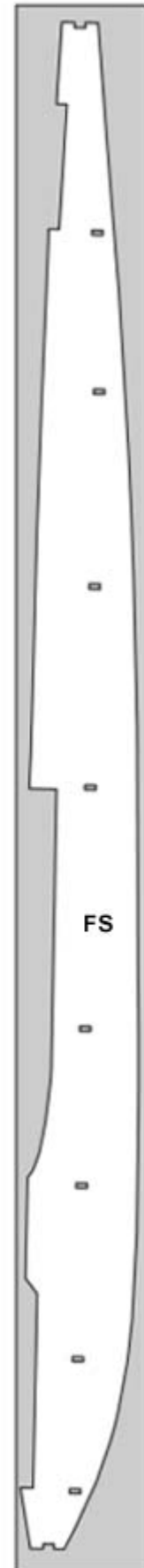

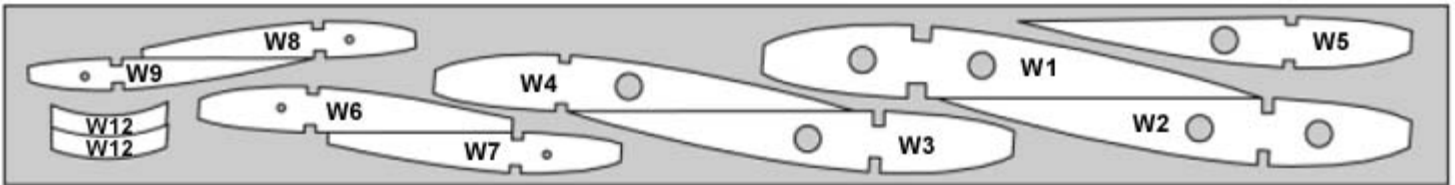

Sheet #1 1/16"x3"x24" Balsa (2 Req.)



Sheet #2 1/16"x3"x24" Balsa (1 Req.)

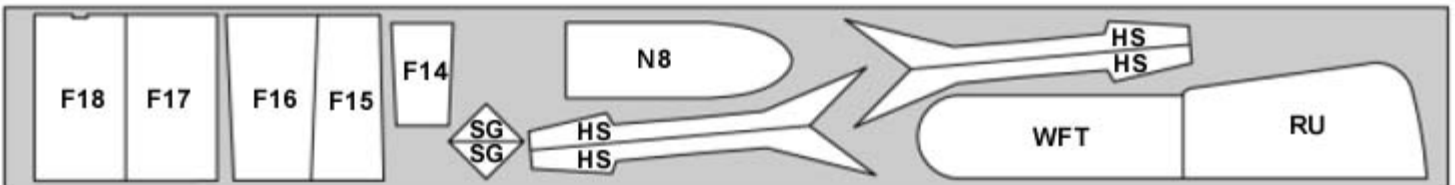

Sheet #6 1/8"x3"x24" Balsa (1 Req.)

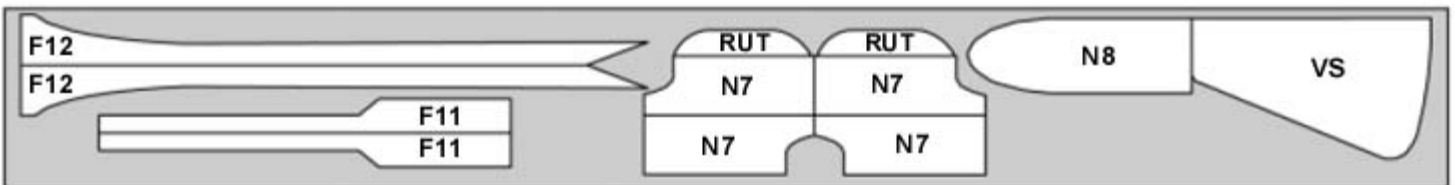

Sheet #7 1/8"x3"x24" Balsa (1 Req.)

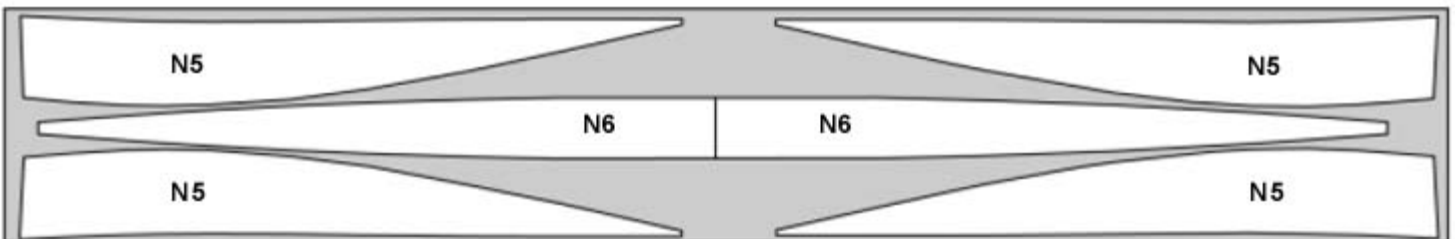

Sheet #8 1/8"x4"x24" Balsa (1 Req.)

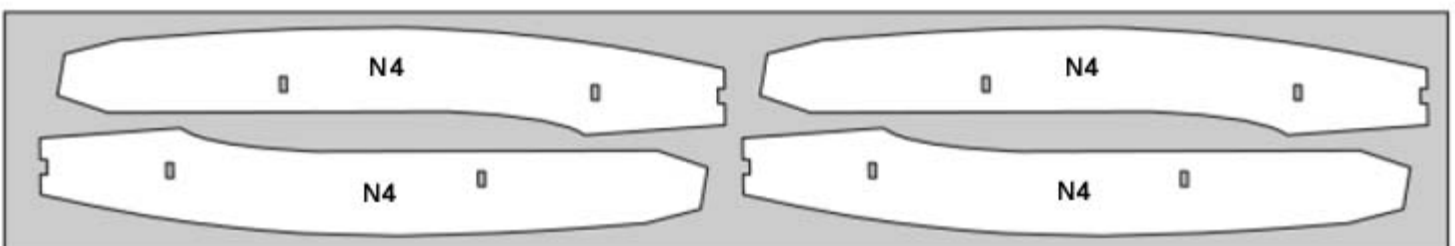

Sheet #9 1/8"x4"x24" Balsa (1 Req.)

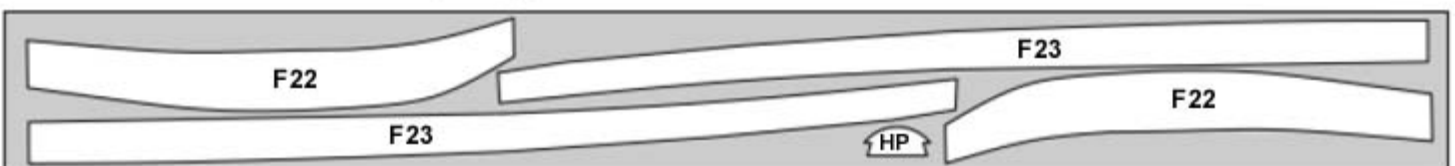

Sheet #3 3/32"x4"x36" Balsa (1 Req.)

## WING CONSTRUCTION

- Prepare the wing sheeting and spars. Cut 4 spars from the  $1/8" \times 3/16" \times 24"$  ( $3.2 \times 4.8 \times 610$ mm) spruce  $23-1/8"$  ( $587.4$ mm) long. Cut 4 spar doublers  $7"$  ( $177.8$ mm) long from the  $36"$  ( $914$ mm) long piece of the same material. Glue a doubler to the top of each spar at one end then taper the last  $2"$  ( $50.8$ mm) of the opposite end on the bottom as shown.

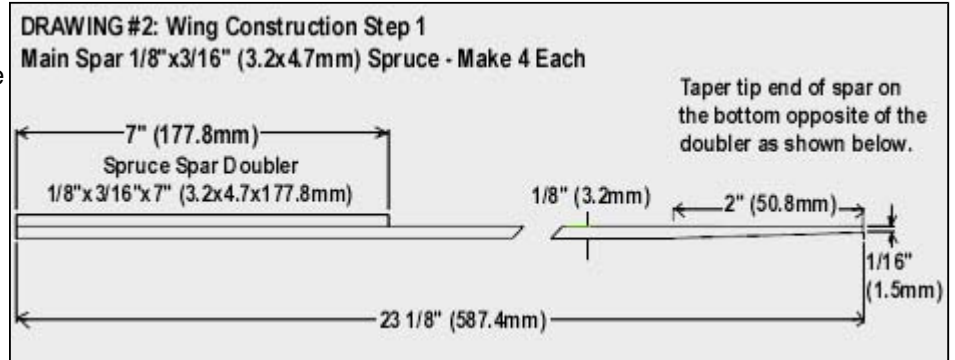

- Cut the four trailing edge sheets from the  $1/16" \times 2"$  ( $1.5 \times 50.8$ mm) sheets  $24"$  long. Save the  $12"$  ( $304.8$ mm) cut-offs from the ends of these sheets for the center sheeting. Taper these from  $2"$  ( $50.8$ mm) wide at the root to  $1-1/2"$  ( $38.1$ mm) wide at the tip. Taper the back edge of the sheet down to about  $1/64"$  ( $.4$ mm) over about  $3/8"$  ( $9.5$ mm). Make 2 top and 2 bottom sheets.

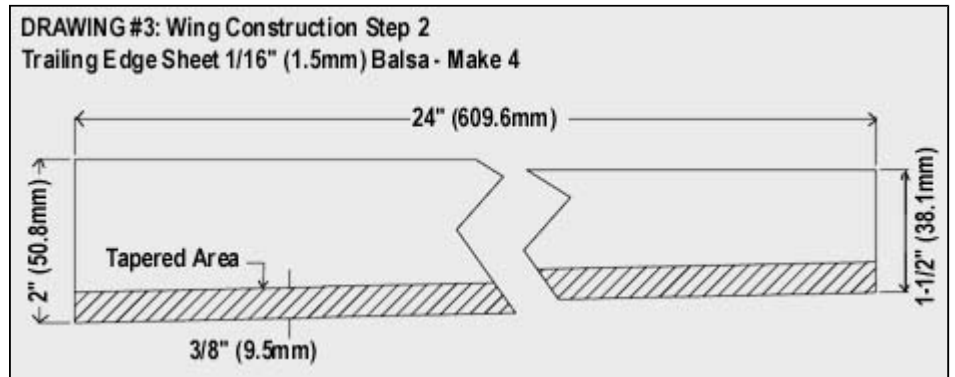

- Cut the two leading edge sheets from the  $1/16" \times 3"$  ( $1.5 \times 76.2$ mm) sheets  $24"$  ( $609.6$ mm) long. Save the  $12"$  ( $305$ mm) cut-offs from the ends for the center sheeting. Taper these from  $3"$  ( $76.2$ mm) wide at the root to  $1-3/4"$  ( $44.5$ mm) wide at the tip. Cut two holes in each for the motor power wires  $1"$  ( $25.4$ mm) forward of the spar and  $1/2"$  ( $12.7$ mm) and  $5"$  ( $127$ mm) from the root. You can make a neat circle cutter with a piece of  $1/2"$  ( $12.7$ mm) brass tube sharpened at the end.

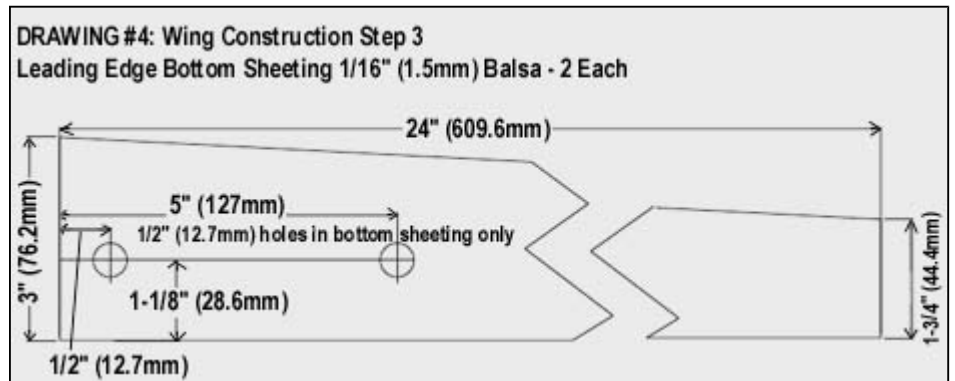

- Cover the plan over the right wing panel with wax paper and pin the leading and trailing edge sheets down to the plan in their proper place. Glue the W-12 piece between them at the tip where shown. Place a  $1/8"$  ( $3.2$ mm) shim under W-12 and the tip sheeting. Glue the bottom spar to the rear edge of the leading edge sheet and pin down just outside of W-9. Make sure the doublers are towards the center of the wing.
- Place ribs W-2 through W-9 down on the spar making sure the ribs are vertical to the sheeting. The W-1 rib is set with the top angled towards the tip slightly using the dihedral gage to set the angle. Glue the ribs only to the trailing edge sheeting and the spar for now.
- Fit and glue the top spar in place. Do not glue the spars together at the tip at this time. Fit and glue the W-14 aileron spar to the trailing edge sheeting between W-5 and W-9 and to the rear of ribs W6, 7, 8, and add the  $1/8" \times 1/4"$  ( $3.2 \times 6.4$ mm) trailing edge doublers between ribs W-5 and W-6, next to W-7, and next to W-9.



7. Install the aileron servo mounting plate SM and its brace SMB on the inboard side of W-6 as shown on the plans. The bottom of this should be flush with the building board.
8. Starting at W-1 and working out to the tip, pull the leading edge sheeting up against the bottom of the ribs and glue them to the ribs. Thin CA works great for this operation, with the help of some accelerator.
9. Get the shaped 1/4"x1/2" (6.4x12.7mm) shaped leading edge and glue it in place. The angled edge should be on the bottom against the sheeting and the side should be flush with the nose of the ribs.
10. Fit and install the 1/8" (3mm) lite ply tip W-11. Taper the rear of W-11 in the hatched area. The front of W-11 should touch the back of the leading edge and W-9 and the trailing edge of this piece should just touch the tip of W-9 at the trailing edge.



Now glue the top spar to the W-11 wing tip. When dry cut the trailing edge sheeting out where the aileron will go in.

11. Shape the top of the aileron spar until it matches the tops of the ribs.
12. Glue one of the pre-shaped trailing edge sheets to the ribs and along the trailing edge and to the tip outline. To allow working time here it is best to use SIG-Bond glue to hold the top sheeting to the ribs and spars.

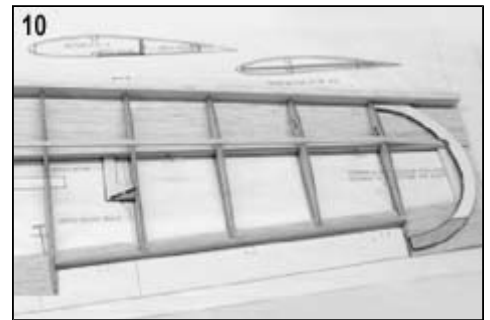

Be sure to pin the sheets down securely while the glue dries.

13. Taper the other two top leading edge sheeting from 2-3/4" (69.9mm) at the root to 1-1/2" (38.1mm) at the tip.

True up and bevel the front edge of this sheet so it is a perfect match to the rear of the leading edge.

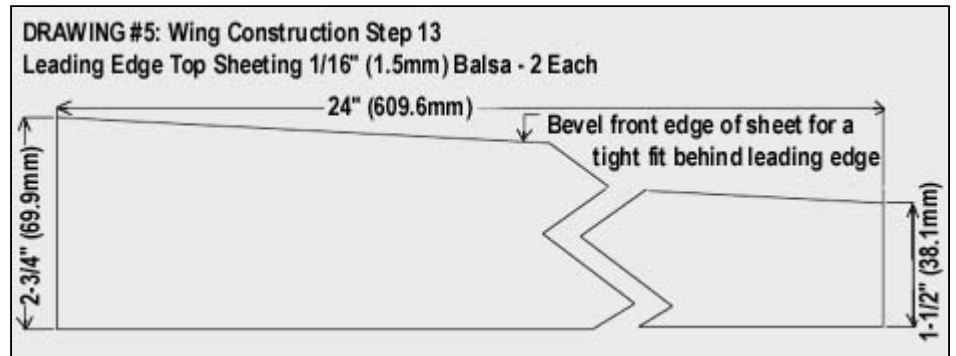

14. Spread SIG-Bond on the ribs and spar then use thin CA to attach the sheeting to the leading edge at an angle that matches the front of the ribs. Now pull the rear of the sheeting down to the ribs and pin in place until the glue dries. If you have trouble getting the sheet to conform you can give it a spray of water on the outside to help it follow the curve of the ribs.

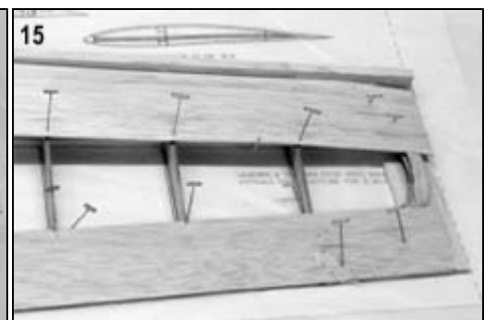

15. Trim and add the curved W-12 to the top of the tip between the sheets.

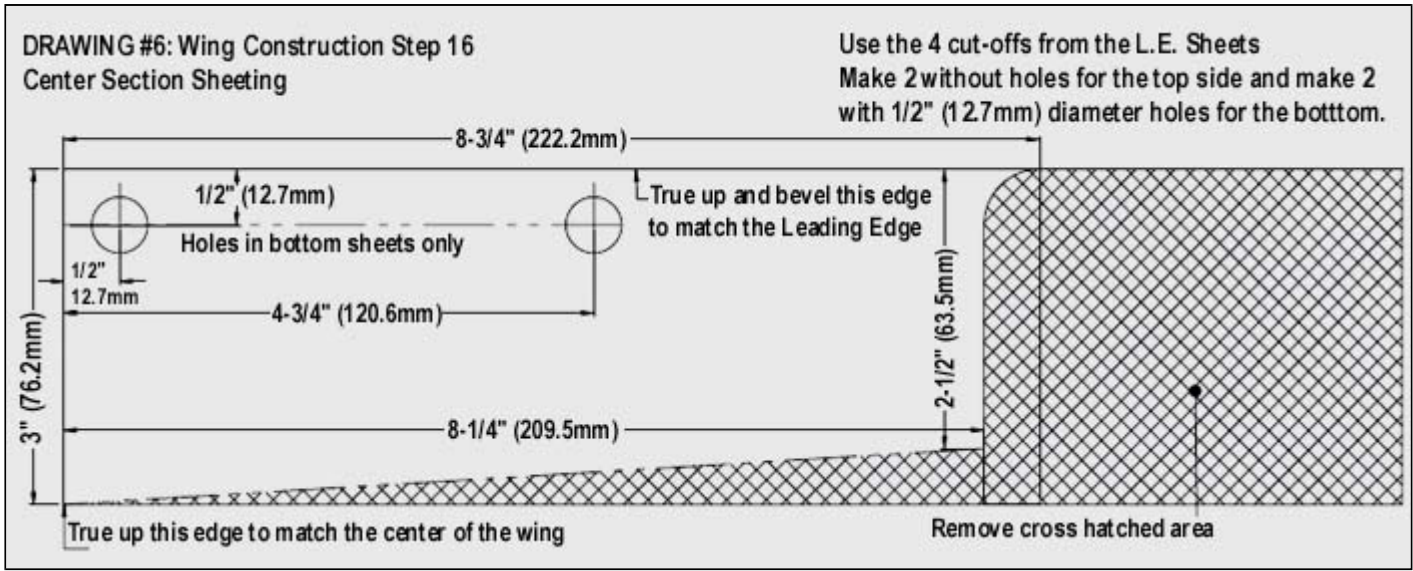

16. Plank the upper center section of the wings. Prepare the center section sheeting as shown in drawings. Fit the front piece first then cut the rear to fit in the remaining space. A neat trick to get the radius in the corner of the sheets is to trace around a quarter.

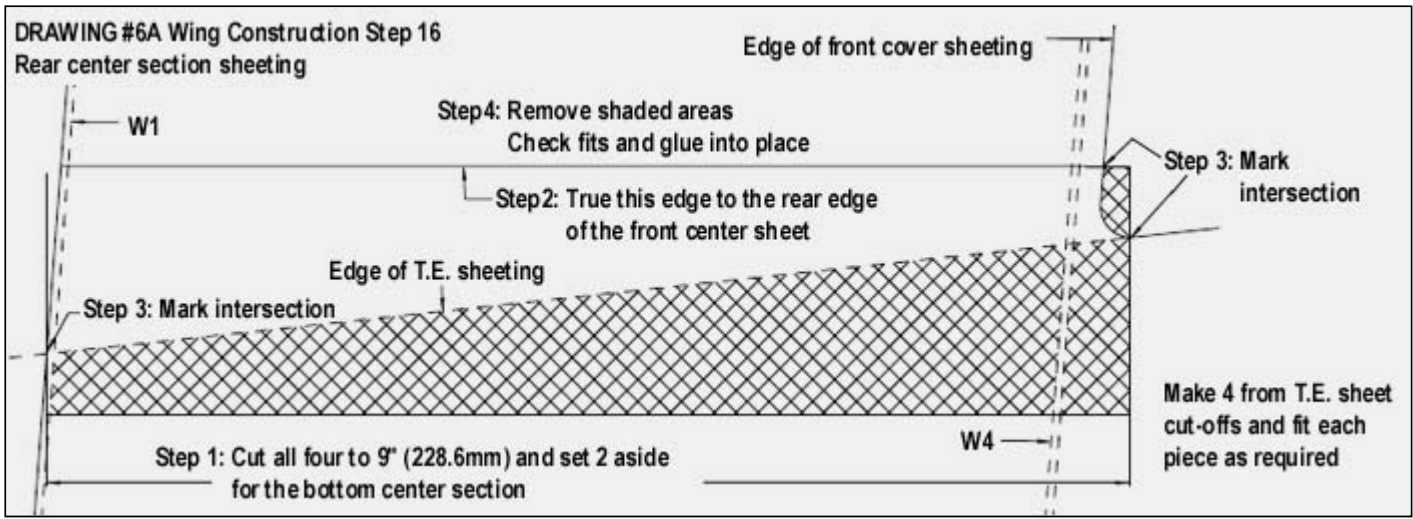

17. Add the 1/16"x3/16" (1.5x4.8mm) cap strips on the top of the remaining ribs.

18. You can now remove this wing panel from the building board, cut away the sheeting from the aileron area, rough shape the leading edge, trim the excess sheeting from the tip and true up the sheeting at the root rib.

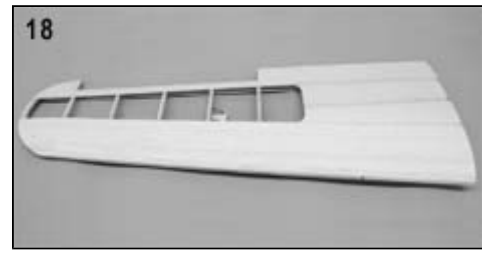

19. Set this panel aside and build the other panel using steps #1 through #18.

20. Make the servo wire guide tubes by rolling a 2"x11" (50.8x279.4mm) piece of typing paper tightly around a section of 3/8" (9.5 mm) dowel then insert this dowel and paper into the holes.



21. When the tube is in position, withdraw the dowel and let the paper unwind in the holes. Tack-glue the tubes in the ribs to keep them from shifting.



Trim the inside end of the tube at an angle to ease the insertion of the servo wires.



NOTE: We highly recommends that you use a speed control for each motor and place each control in the nacelle behind the motor. For this you will need to also cut a hole in the bottom of the tube just inboard of F-3 for the receiver lead of the speed control.

22. Feed motor wires through the hole in the leading edge sheeting next to W-1, through the front hole in rib W-2 and out the hole just short of rib W-3. Tape the wires together to keep them from slipping out. (refer to photo 23)

23. The two wing halves are now joined. Place the wing halves upside down on your work surface with their root ribs facing each other. Use lengths of balsa stock to shim the leading and trailing edges of the wing panels, supporting them so that their top wing spars are flat to the work surface. Make sure the root ribs are flush to each other. Cut two pieces of the 1/8"x3/16" (3.2x4.8mm) spruce spar material 5" (127mm) long for the spar joiners. Insert the joiner for the top spar in one side and glue to the spar and the top skin.

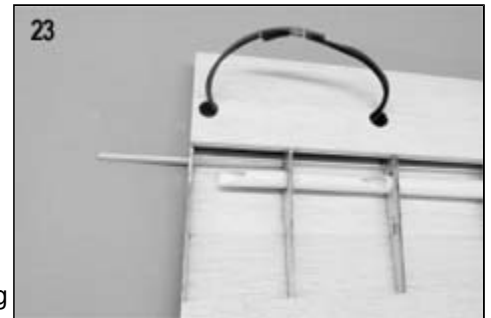

24. Using 30-minute epoxy, spread a thin coat of glue on the root rib of the other wing and on the spar joiner that extends from the first panel. Slide the two halves together and run a strip of masking tape over the seam on the top of the wing to hold it together and to contain any epoxy that tries to seep out. Now lay the wing up side down with the spars flat on the building board and tape the leading edge and trailing edge securely together so the panels line up exactly. Glue in the bottom spar joiner and clean up any excess epoxy with a paper towel and alcohol then set aside to cure.



25. While waiting for this to cure, prepare the center sheeting for use. Cut the two 1/2" (12.7mm) holes for the servo wires in the front sheets on a centerline 1/2" (12.7mm) back from the leading edge and 1/2" (127 mm) and 5" (127mm) out from the center and glue these sheets onto the bottom center section, behind the leading edge sheeting. (Refer to drawings at step #16)

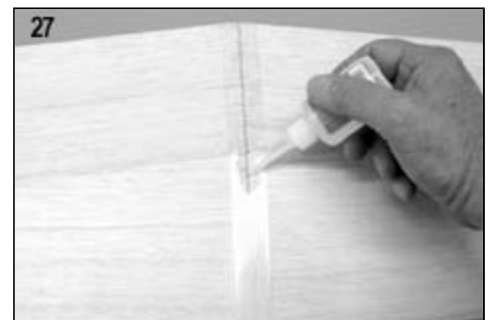

26. You can now remove all the tape and finish shaping and sanding the wing.

27. Glue the 1" (25.4mm) fiberglass tape over the center joint of the wing top and bottom. Medium CA works well for this application. Rub in a second coat of glue and let cure before sanding out any lumps.

28. To shape the ailerons cut the 1-1/4"x5/16"x24" (31.7x7.9x609.6mm) piece of trailing edge stock into two 10-1/2" (266.7mm) sections. At one end of each piece measure up 7/8" (22.2mm) from the trailing edge and make a mark. Draw a line with a straight edge from this mark to the corner at the thick side at the other end. Cut this triangular piece off and sand smooth. Draw a centerline down the thick edge of the aileron and bevel down to the line from top and bottom. Now fit the aileron to the cutout at the trailing edge of the wing allowing 1/32" (.8mm) gap at each end. Mark each aileron for left and right.

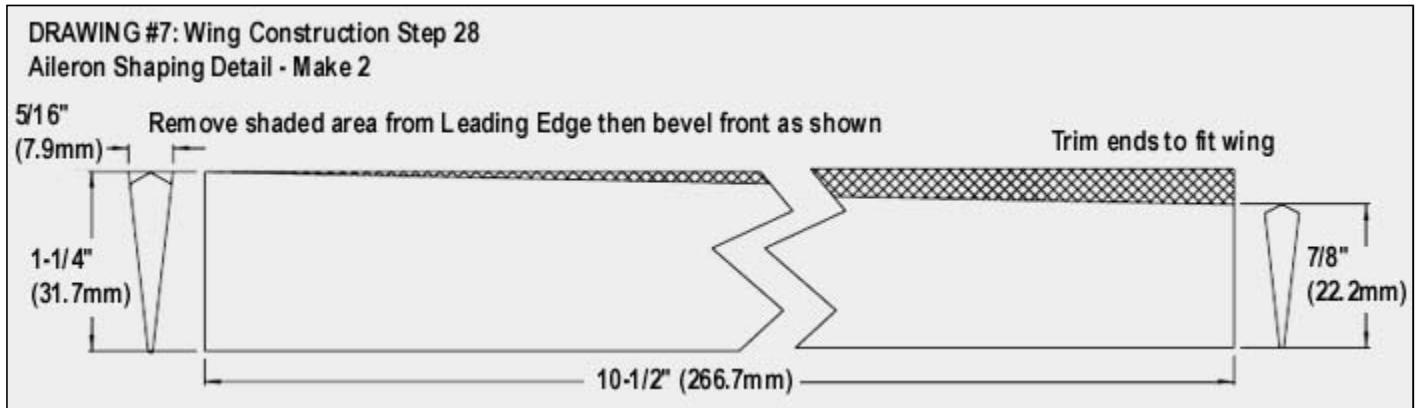

## FUSELAGE CONSTRUCTION

To make the assembly of the nacelle and fuselage assembly quicker and more efficient, pre-form the following parts so they can be drying while the stabilizer and rudders are built.

29. Secure parts numbered N-4 (4 pcs.), N-5 (4 pcs.), and N-6 (2 pcs.) from their laser cut sheets #8 and #9.
30. Prepare a soaking solution of 1-cup hot water and 1 cup ammonia and pour into a small plastic tub or coffee can.

31. Soak the rear 2/3's of the N-4's and the front 2/3's of pieces N-5 and N-6 in this solution for an hour, remove and pat dry.

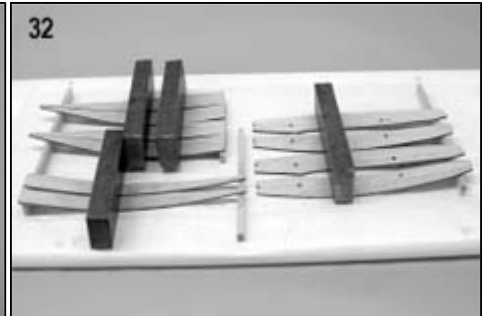

32. Shim and weight the pieces as shown with 3/4" and 1/2" (20 and 12.7mm) shims and allow them to dry for a day. Make sure you bend 2 rights and two lefts of N-4 and N-6

33. Get the two F-13 fuselage bottom pieces from the 1/16" (1.5mm) sheet #2 and the two F-22s from the 3/32" (2.4mm) sheet #3. These need to be preformed before being glued to the fuselage. Soak them in warm water as before then weigh them down with 3/4" (20mm) shims at each end. The weight should be applied about 2/3's of the way towards the small end of the F-13's and the curved end of the F-22's. Make sure you make a left and right when doing the F-22's.

## TAIL SURFACE CONSTRUCTION

34. Cut 8 rib blanks 2-1/4" (57.1mm) long from 3/32"x1/4" (2.4x6.4mm) balsa and 2 end ribs 1-7/8" (47.6mm) long from 1/4" (6.4mm) square. Stack these up side by side with one of the 1/4" (6.4mm) end ribs on the outside of the stack. Align one end against a straight edge, square up the stack, and tape together tightly. True up the squared end with a sanding block then measure 3/8" (9.5mm) in from this end and make a mark, then mark the center 1/8" (3.2mm) in from the edge.

Also mark the top of this stack as shown.

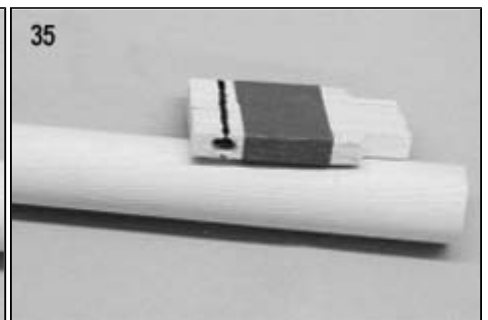
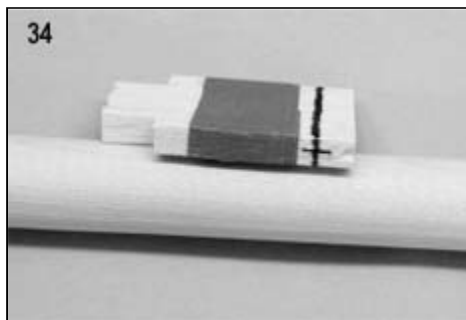

35. With a 1/8" (3.2mm) bit, drill through the stack at this mark keeping the drill centered all the way through. If you have a drill press with a vice, it makes this job easier. Elongate the holes in the end ribs into a 1/4" (6.4mm) slot.

36. Cover the stabilizer plan with wax paper then pin down the 1/4" (6.4mm) square leading and trailing edges over the plan.

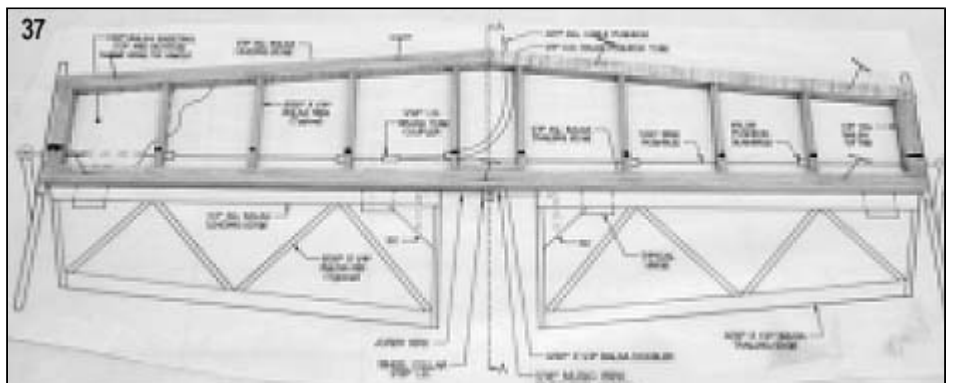

37. Cut to length and glue in the ribs where shown on the plan keeping the hole to the rear and the marked side up. Glue a piece of 1/8"x1/4" (3.2x6.4mm) balsa between the center two ribs at the trailing edge.

38. Cut two 3/8" (9.5 mm) from the end of each 1/8" (3.2 mm) pushrod tubes and insert these as pushrod bushings in the ribs in the four places shown on the plan.
- Slide a piece of 1/32" (.8 mm) music wire through the holes and bushings and align the bushings so the wire slides freely from side to side before gluing the bushings in.

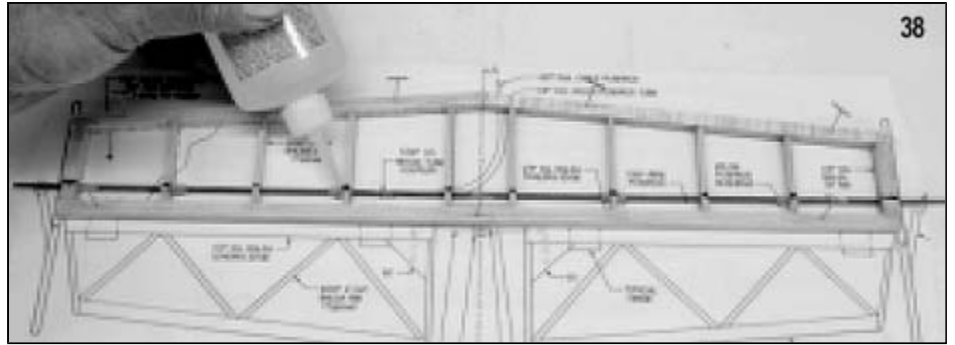

39. Remove the pins, sand the top of the stabilizer frame to get it level, then apply the 1/32" (.8mm) sheeting to the exposed side. When dry, remove from board, and trim excess sheeting.
40. Use a 1/8" dia. (3.2mm) bit to drill through the bottom of the leading edge, as shown on the plans, to allow the rudder pushrod guide to pass through.

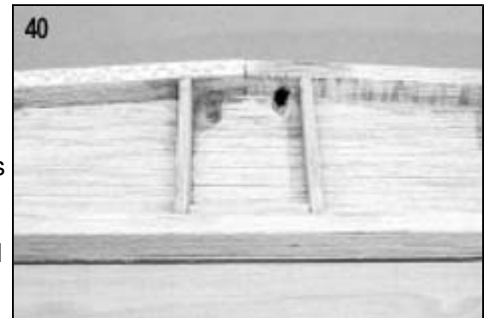

41. Form the pushrod guide tube using a heat gun. This is easy to do if you insert a toothpick or small bamboo skewer stick in one end then apply bending pressure to the end of the tube as you carefully heat it with a heat gun in the bend area. As the plastic heats up you will feel the resistance decrease. Keep the pressure on until you can get it to bend 180 deg. without kinking as shown in the picture. Hold in this position until it cools. When the pressure is released it will spring open and you should have a nice tight 90 deg. bend, without kinks.



42. Trim the tube to length and check to make sure the .027" (68mm) cable slides easily through the tube. Hint: The cable will slide easier if you pre bend it to the rough shape of the tube. When satisfied with the fit, glue the tube in as shown. You will need to elongate the hole in the rib where the tube goes through next to the wire.

43. Get the 3/32"x1-1/2" brass tube from the hardware bag and cut it into four equal sections. This can be easily done by rolling the tubing on a hard surface while applying pressure with a sharp knife on the cut line.

44. Slide the 1/32" dia. x16" (.8x406mm) music wire pushrod into the stab. Pass it through the 3/32" (2.4mm) brass tube solder sleeve in the bay where the wire and cable are soldered together and on out the other side until the wire is centered.

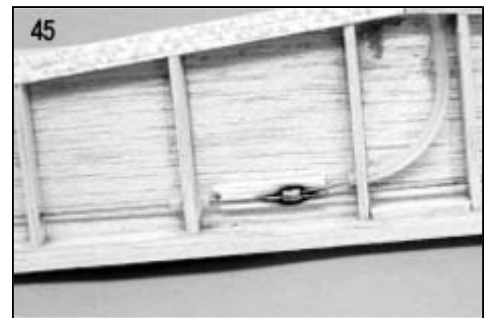

45. Slip the cable into the sleeve with the wire and adjust until the sleeve is about half way between the rib bushing and the cable tube. Slip a scrap piece of balsa wood between the sleeve and the bottom skin to protect the skin. Now solder this assembly together using STA-BRITE® silver solder and flux. When cool remove the scrap of wood and check for freedom of motion.

46. Sand the bottom flat and glue on the bottom 1/32"(.8mm) skin then trim. Round off the leading edge.

47. Cut and pin down the 1/4" (6.4 mm) square elevator leading edges and the 3/32"x1/4" (3.7x6.4 mm) trailing edges. Cut to length and glue in the 3/32"x1/4" (3.7x6.4mm) ribs leaving them full depth for now. Glue the SG gussets in the inner corners as shown.

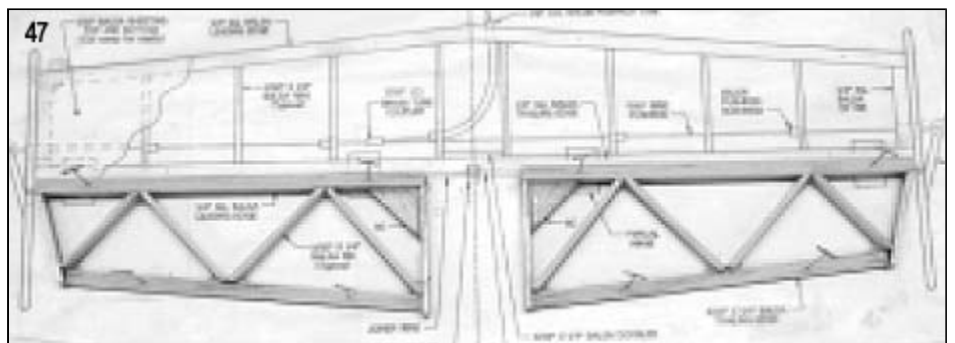

48. Remove the elevators from the plan, sand them to the tapered shape and bevel the leading edge.
49. To make the elevator joiner and control horn, you will need the 3-1/2" (88.9mm) piece of 1/16" (1.5mm) music wire, the 1/16" (1.5mm) I.D. wheel collar, the 4-40 headless set screw, and the 4-40 RC link from the hardware bag. Mark the exact center of the wire and file a slight flat there. Slide the 1/16" wheel collar onto the wire until the setscrew is positioned directly over the flat, put a drop of Loctite® thread locker or medium CA in the set screw hole and tighten the screw tight against the flat.
50. Put a drop of Loctite® or medium CA on the set screw threads and screw the 4-40 RC link down on the setscrew until it contacts the wheel collar. It is important that when the glue sets that the pin in the RC link is parallel to the music wire.
51. Measure out 1" (25.4mm) from each side of the wheel collar on each side and mark. Bend the wire 90 deg. at each mark making sure the bends are 90 deg. from the control horn and parallel to each other.

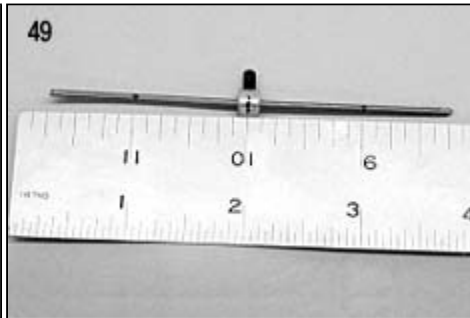
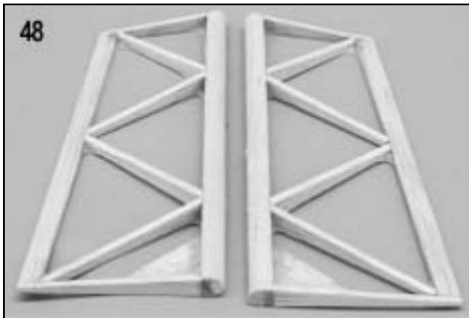

52. Mark the center of the bottom of the stabilizer at the trailing edge then make a mark 1/8" (3.2mm) either side of the center mark. Saw 1/8" (3.2mm) deep at each mark and remove the wood in between. This provides clearance for the wheel collar on the control horn.

53. To mark where to drill the elevators for the control horns, pin the elevators to the stabilizer with the outboard ends about 1/16" (1.5mm) in from the rudders. Lay the control horn over the elevators with the collar centered in the notch and mark where the wires need to enter the elevators.

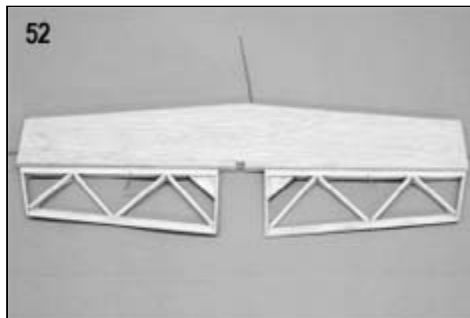

54. Remove the elevators and drill with a 1/16" (1.5 mm) bit where you have marked. Cut a 1/16" wide and 1/16" (1.5 x 1.5mm) deep groove from the drilled hole to the inside end of the elevator. Trial-fit the elevator horn into the elevators and make any adjustments needed to get the wire to lay flush with the elevator leading edge and the elevator leading edge to match the stabilizer trailing edge.



55. Place pieces of wax paper on the stabilizer where the horn will contact it. Use 5-minute epoxy or thick CA to glue the horn into the elevators and then pin up against the stab to hold everything in alignment while the glue sets.

56. On a piece of wax paper glue the RUTs to the top of the RUs then sand smooth and round the edges. Smooth and round the VSs also and layout the lines where they will glue onto the ends of the stabilizer.

Drill and slot to match the rudder pushrod exits in the end ribs.

## NACELLE SURFACE CONSTRUCTION

The nacelles are built similar to the fuselage and you can use them to master the shaping technique that will be used on the fuselage later.

57. Taper the last 3/8" (9.5mm) of the inside rear of each nacelle side.
58. Insert N-1 and N-2 between a right and left side and use a rubber band to hold them together.
59. Place this assembly on a flat surface with N-1 facing down. If you are using CA glue this should be done on a piece of wax paper. Square the sides to the work surface and glue this assembly together.
60. Insert N-3 into the proper slots on the inside of the nacelle sides, pull the rear of the sides together, and glue them together.
61. Center the wide end of N-6 on the bottom flat of N-1 so that it overhangs the front about 1/16" (1.5 mm), align the rear of F-6 with the rear of the nacelle and glue into position.

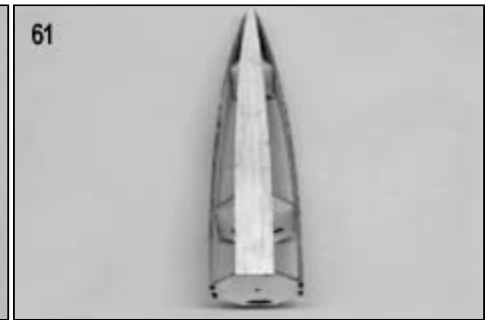
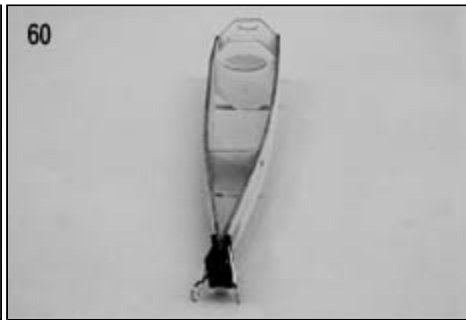

62. To add the N-5 bottom corner pieces, it is now necessary to bevel the edges of the sides and bottom to match the angles on the bottom of the bulkheads as shown.

63. Glue the preformed N-5's to the bottom corners of the nacelle.

64. Round off the bottom of the nacelle now by first sanding the edges of the N-5 down flush with the sides and bottom. Now round off the remaining corners to obtain a well-rounded shape. The tops of the nacelles will be finished off after they are mounted on the wing.

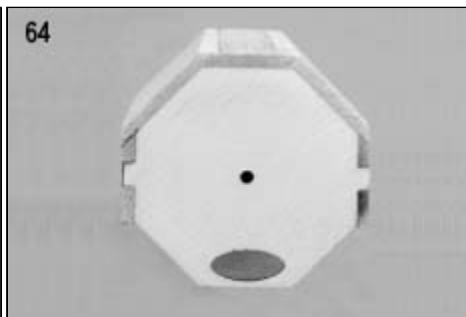
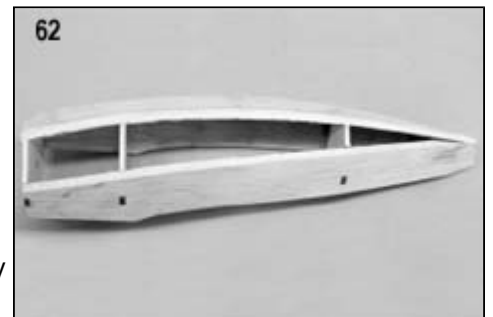

65. Repeat these steps for the remaining nacelle.

NOTE: Now is the time to decide if you want to install landing gear. If you choose this option, refer to the optional landing gear drawing below. If you choose to build this model without the optional landing gear, proceed to next step.

## Optional Main Landing Gear

### Parts Required (not furnished)

- 2 - SIGSH596 Nose Wheel Strut
- 2 - SIGSH523 1/8" Landing Gear Clips
- 1 pair - KAV0098 2" Wheels
- 1 pkg. - SIGSH586 1/8" Wheel Collars

### Assembly Sequence

1. Build nacelles through to step 65.
2. Cut out 2 gear mounting plates from hard plywood.
3. Drill holes at the locations shown on the drawing.
4. Bend the gear strut as shown and screw it to the mounting plate using SIGSH523 Landing Gear Clips.
5. Cut opening in the bottom of the nacelle to clear the coil spring.
6. Glue the gear strut assembly to the back of N-2.

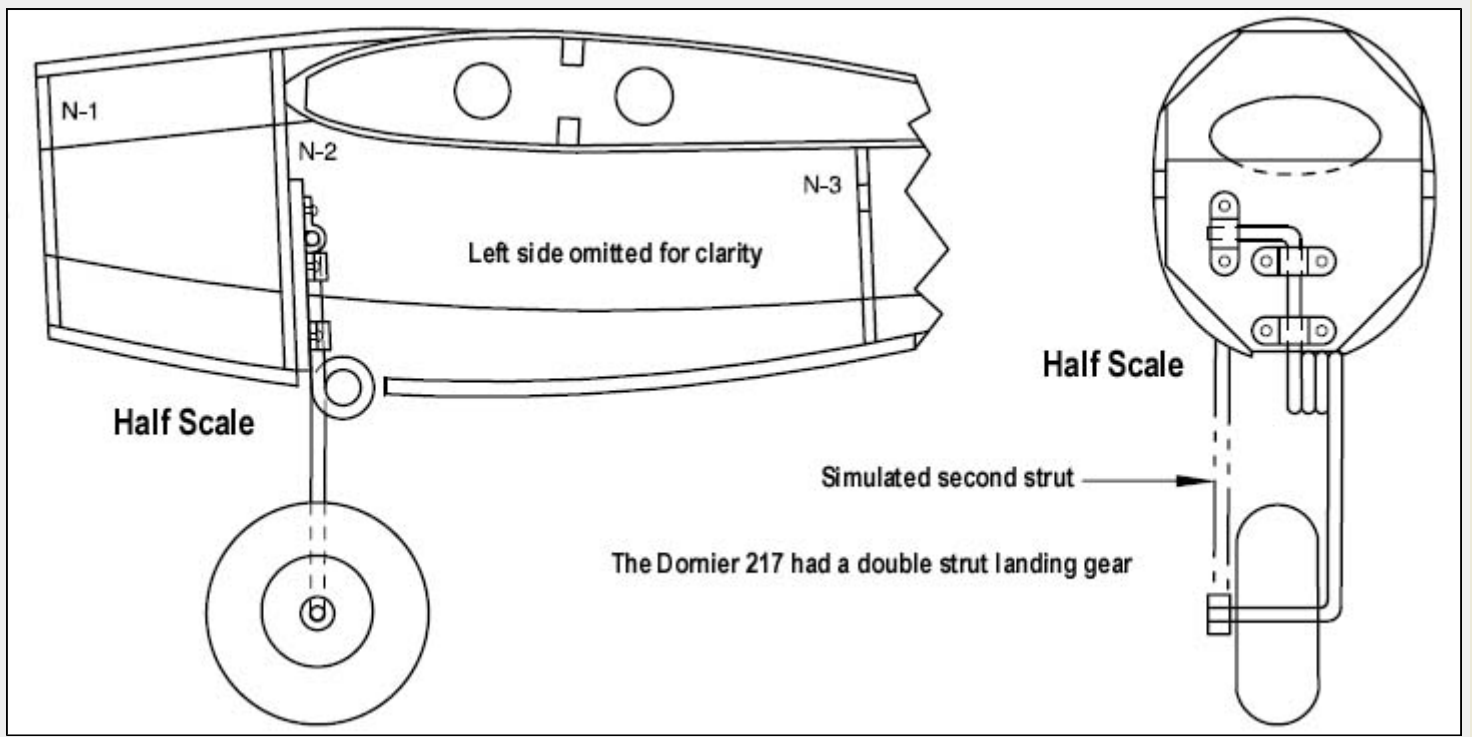
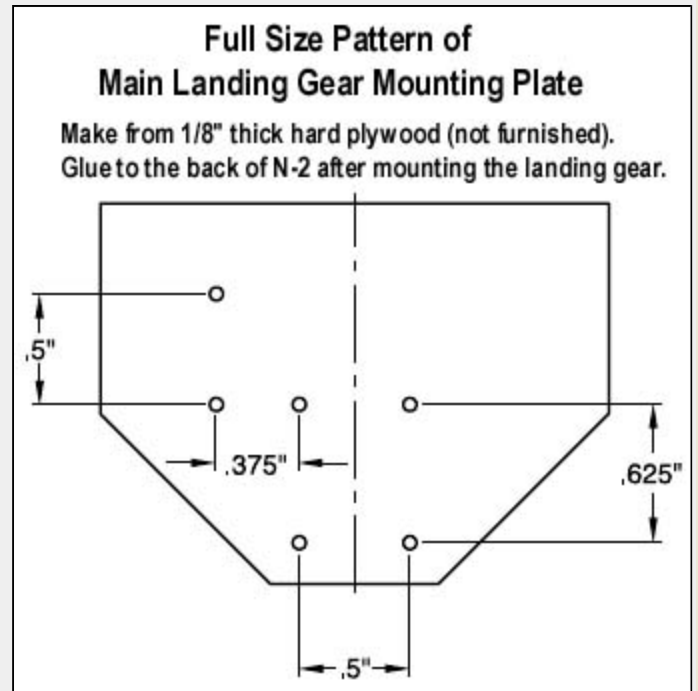

## FUSELAGE CONSTRUCTION

66. Locate and remove both fuselage sides from the two #4 sheets and mark a left and right side.
67. Using bulkhead F-4 in its slot on both fuselage sides at the leading edge of the wing as a guide, draw a line to the top of the fuselage at the front of the bulkhead. This line locates the joint between F-11 and F-12.
68. Do the same with F-8 in its slot at the tail end. This locates the front of the 1/8"x1/4" (3.2x6.4mm) balsa stabilizer braces.



69. Glue on F-11, F-12, and the 1/4" (6.4 mm) square parts at the nose.

70. Glue in the 1/8"x1/4" (3.2x6.4mm) stabilizer supports.

71. Glue in the 1/4" (6.4mm) square balsa wing hold down plate supports ahead of F-6 and below F-12.

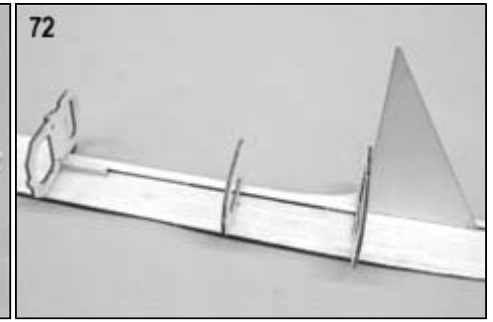
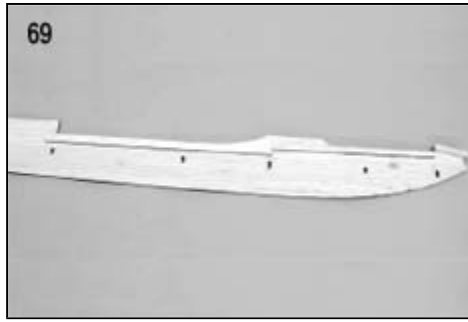

72. Locate bulkheads F-4, F-5, and F-6 and glue onto one fuselage side, making sure they are perpendicular to the side.

73. Glue the other side to these bulkheads.

74. Glue the 3 F-20s together then glue them onto the 1/4" (6.4mm) square wing hold down supports and F-6. This will help hold the fuselage square for the following steps.

75. Insert and glue in F-3, F-2, and F-1 in that order.

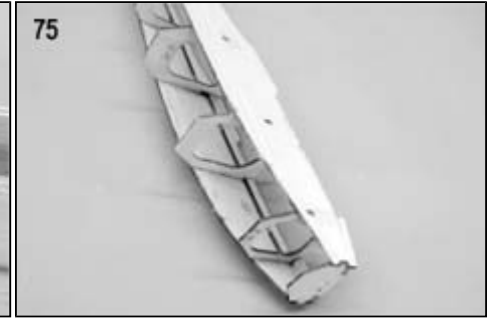

76. Glue in F-7 making sure the pushrod guide hole nearest the top of the fuselage is closest to the right side when looking towards the front.

77. Glue in F-8 making sure the top pushrod guide hole is to the right as in the previous step.

78. Glue in F-9 making sure the pushrod guide hole is offset to the left, and then add F-10.

79. Double check the fuselage for straightness at this point, then go back and double glue all your bulkheads to the fuse sides.

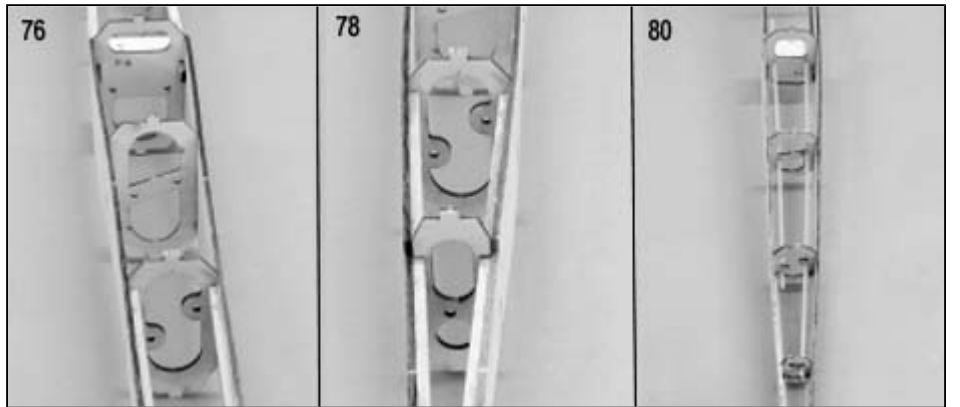

80. Install the two 1/8" (3.2mm) nylon pushrod guide tubes. Sand the bottoms of F-1, F-2, and F-3 to an angle to match the curvature of the F-16 bottom sheeting.

81. Notice the notch at the rear of F-13. This notch engages the tab on the bottom of F-5. Glue an F-13 to F-5 and F-4, making sure that the front of F-13 centers on F-1. When these are dry glue to F-3, F-2, and F-1.

82. Laminate the second F-13 on top of the one that is glued to the formers.



NOTE: If you are installing landing gear, now is the time to make provisions for the tail wheel. Refer to the drawing below. If you are not adding landing gear to your model, proceed to the next step.

## Optional Tail Wheel Installation

### Parts Required (not furnished)

- 1 - 1/32" Dia. x18" Music Wire
- 1 - 1/8" O.D. x18" Plastic Tube
- 1 - 1/16" Dia. x3-1/4" Music Wire
- 1 - SIGSH132 Tailwheel Bracket
- 2 - #4x1/2" Sheet Metal Screws
- 1 - 1/16" I.D. Wheel Collar
- 1 - 3/4" Dia. Tailwheel
- 1 - 1/32"x3/16"x1/2" Brass Strip Stock
- 1 - 1/8"x1-1/2"x2-1/2" Lite-Ply
- 2 - 1/4"x2-1/2" Balsa Triangular Stock

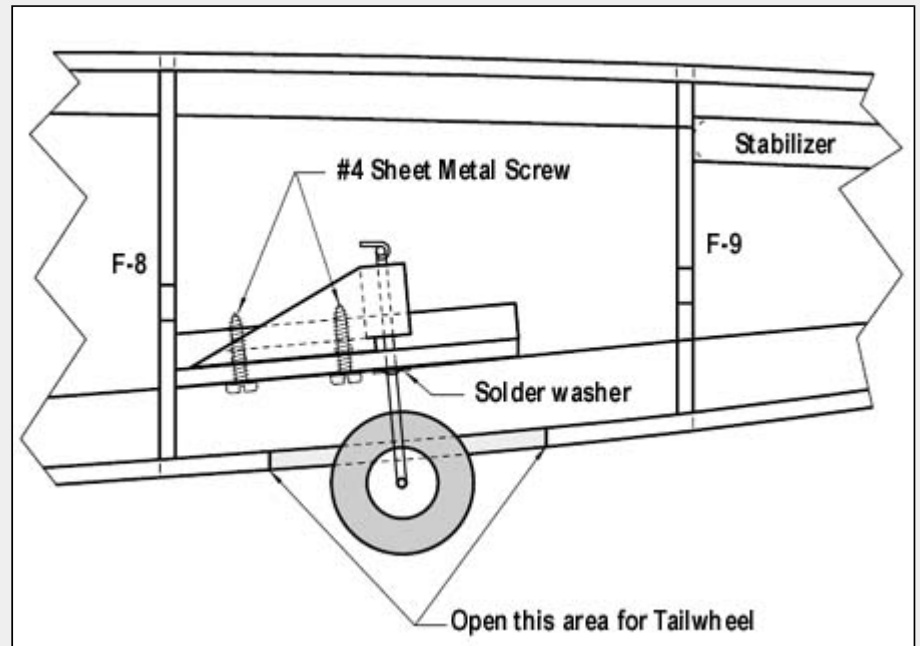
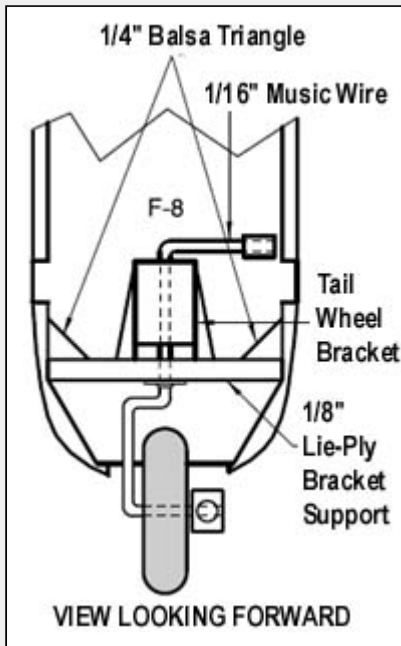
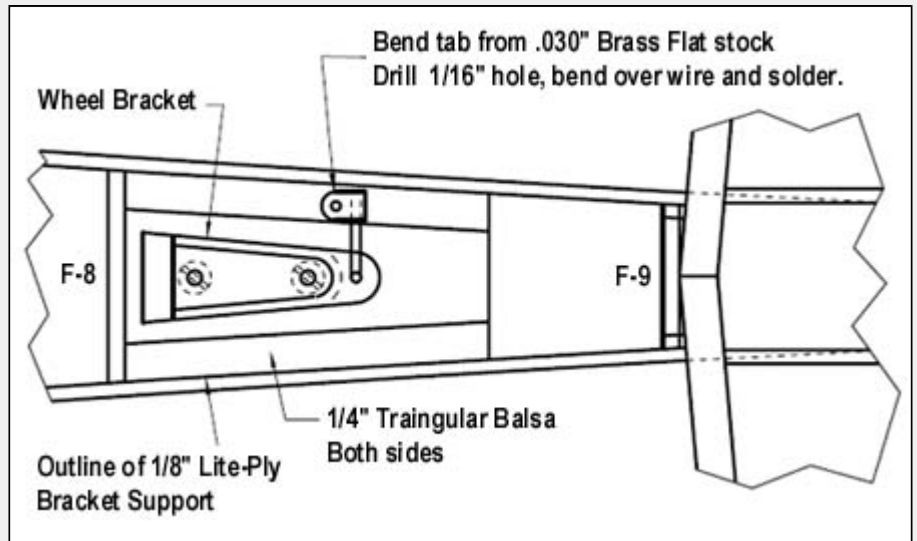

83. Glue F-24 on the bottom of the rear fuselage.

84. Glue F-18 to the top aft of the wing.

85. Bevel all the corners on the top of the fuselage from the wing to the tail and the bottom of the fuselage like you did on the bottom of the nacelles.

86. Glue the F-22's to the lower nose section starting from F-5 and working forward. Sand the edges of the F-22's flush with the F-13's then laminate the F-14 through F-18 over them. Taper the back edge of F-18 to fair into F-24.

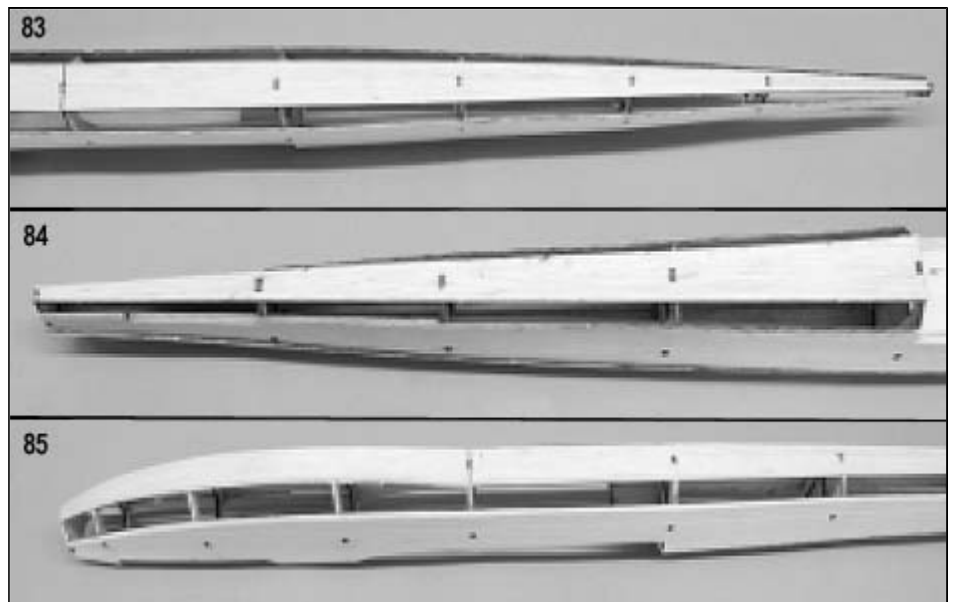



87. Glue the F-23's to the lower rear fuse from F-5 back.
88. With the 3/32"x1" (2.4x25.4mm) balsa strips glue the top rear corners in from F-6 to the tail.
89. Sand the top of the fuselage so that the sides between F-1 and F-2 are perfectly flat.
90. Fit the 1/4"x1-3/4"x1-1/2" (6.4x44.5x 38.1mm) balsa piece on the top of the nose from F-1 back to the rear of F-2 and glue in. Now sand the front and back of this block until it matches F-1 and F-2.



91. Trace the nose block and tail block outlines from the plans onto a sheet of paper, cut them out, and glue them on the proper blocks with a glue stick. The glue stick will hold them while you saw the blocks to the outline then they will peel off easily. Tip: When cutting out the blocks. Cut them about 1/32" (.8mm) oversize. It is a lot easier to sand off a little excess than to try to add wood later.
92. Glue the blocks on the fuselage in their proper places.
93. Glue F-3T to the fuselage side at the rear of the hatch area. The angle of the bulkhead should match the angle on the fuselage sides and the corners that meet the sides should be flush with the top of F-11.
94. Bevel the bottom of the F-25s to match the top surface of the sides between F-3T and F-4 and glue these pieces onto the bulkheads. Sand the front and rear of the F-25 flush with the bulkheads, then sand the tops of them down, flush with the tops of the bulkheads.
95. Glue the 1/4"x1-3/4"x1-1/2" (6.4x44.5x38.1mm) block on the top of this section.
96. Remove excess wood then round off the fuselage, as you did the nacelles.



97. Join HB-1 and HB-2 on a flat surface.
98. Sand the top of the fuselage in the hatch area until it is perfectly flat and the top blocks behind F-3T and ahead of F-2 flush with the bulkheads. Tape a piece of wax paper over the hatch area then pin the HB pieces down over the wax paper. This forms the base of the battery hatch and cockpit.
99. Bevel the bottom of HR so it makes a good joint with HB-2 and glue it on the rear of the hatch so it lays flush against F-3T.

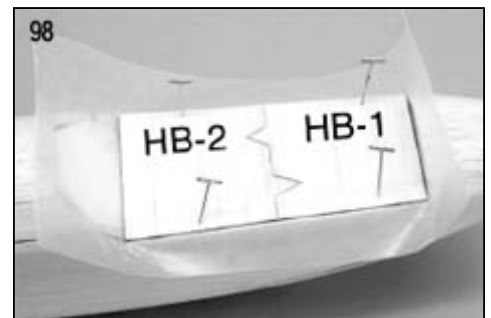

100. Glue HF to the front of the hatch, centered on F-2.

101. There are four HS's on sheet #6. Bevel the bottom of one of these to sit flush on the hatch bottom and snug against F-3T. Now do the same for the other side.

102. Laminate the other two HS's to the outside of the two that are glued down in the same way.

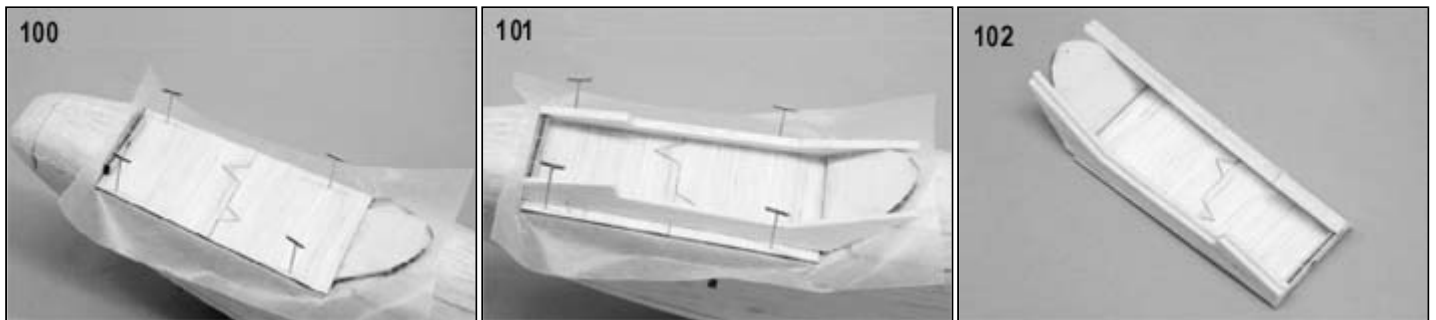

103. While the hatch is still pinned in place drill a hole with a 1/8" (3.2mm) bit through the hole in the front of HF through former H-2.

104. Remove the hatch from the fuselage and glue a 3/8" (9.5 mm) piece of 1/8" (3.2mm) dowel into the front of the hatch so that about 3/16" (4.8mm) sticks out the front.

105. Sand a flat area on the top front part of the hatch sides and glue down the 1/4"x1-3/4"x1-1/2" (6.4x44.5x38.1mm) top block. Sand this part flush with the front of the hatch and the instrument panel in the rear then glue in HP.

106. Pin the hatch assembly back onto the fuselage and rough shape the nose back to the wing opening.

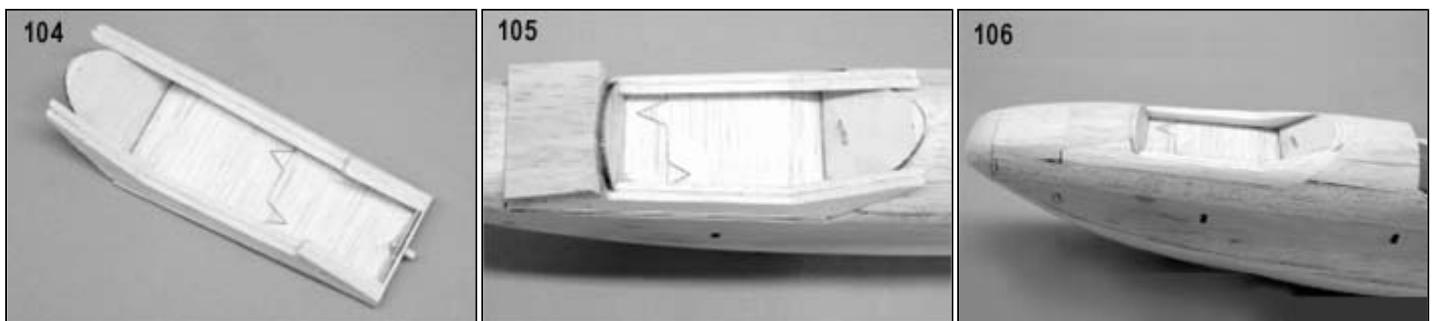

## AIRFRAME ASSEMBLY

107. Sand a 2" (50.8mm) wide flat at the trailing edge and leading edge in the center of the wing. This will allow F-4T to slip between F-4 and the leading edge of the wing. Mark the exact center of F-6 and F-4. See Drawing.

108. Fit wing onto the fuselage lining the centerline of the wing up to the centers you marked on the bulkheads and to make sure there is room for F-4T at the leading edge.

109. Glue the 3/16" (4.8mm) dowel into the hole in F-4T so that 1/4" (6.4mm) protrudes from the front, then cut the dowel on the backside off flush with the bulkhead.

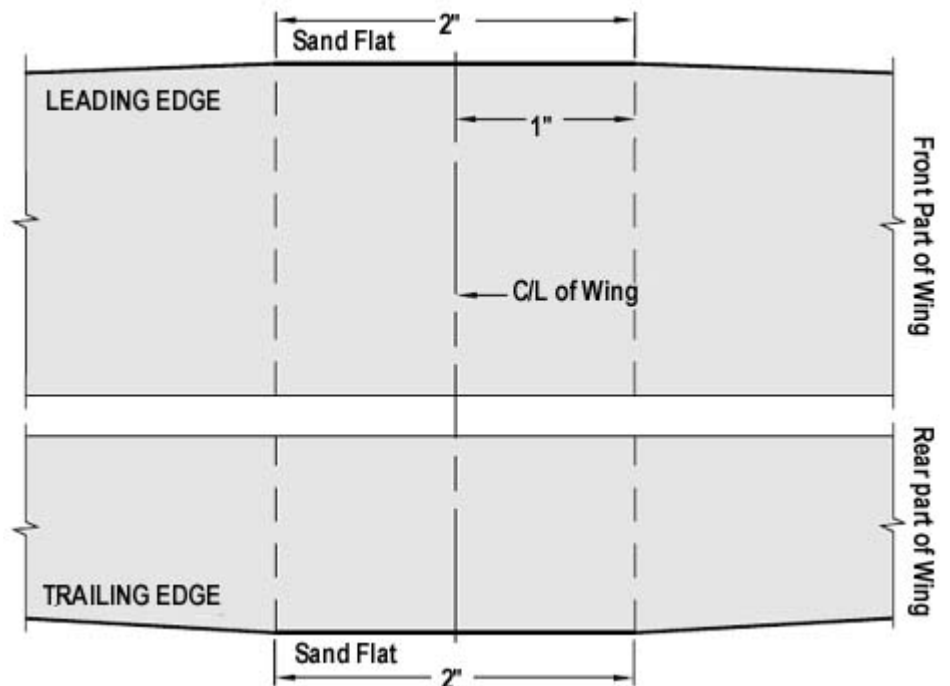

110. Trial fit F-4T and dowel into place on F-4 making sure F-4T and F-4 are flush to each other. Remove F-4T, lay a sheet of waxed paper between it and F-4 in the wing saddle and replace F-4T.

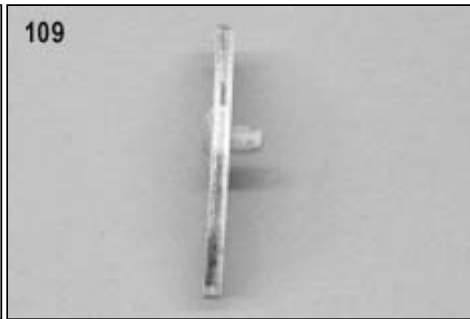

111. Place the wing back into the wing saddle making sure the flat at the leading edge of the wing is flush with F-4T and the centerlines are in position. Tack-glue the wing to F-4T being careful not to allow excess glue to seep between the bulkheads and the dowel.



112. When dry remove the wing and finish gluing F-4T to the leading edge. For extra strength glue a 1-1/2" (38.1mm) piece of fiberglass tape in the joint between the bottom of F-4T and the bottom of the leading edge.

113. Place the wing back on the fuse and check the fit. You may have to relieve the trailing edge a little to allow the wing to seat in the saddle. Check the fit of F-6T against F-6 and the top of the wing. The edges of F-6T should match F-6 when sitting on top of the wing.

114. Remove the wing and place a piece of wax paper under the trailing edge and up F-6. Slip a 1/32" (.8mm) shim between the waxed paper and F-6 to position F-6T properly, replace the wing then glue F-6T onto the trailing edge of the wing. You should now be able to remove and insert the wing without difficulty.

115. Glue a 3/16"x1/4" (4.8x6.4mm) balsa shim on the wing bolt platform, W-13, sand a slight flat on the bottom as shown on cross section W-1 on the plans, then glue this to the wing and F-6T in the center.



116. Center wing on the fuselage and drill perpendicular to W-13 through the pre-cut hole all the way through the wing and the F-20 plate in the fuselage with a 13/64" (5.3mm) bit.

117. Remove the wing and enlarge the hole in the fuselage plate to 1/4" (6.4mm). Using a 10-32 bolt and washers pull the 10-32 blind nut into the mounting plate and glue. If any of the blind nut protrudes above the plate, file or grind it off flush and clean the threads.

118. Layout the position of the sides of the wing trailing edge fuselage fairing. Measure 2-1/8" (54mm) forward from F-6T on the centerline and make a mark. Then measure 1" (25.4mm) off to each side of the centerline and mark as shown. Fit the two WFSs to the top surface of the wing and glue them down to the sides of F-6T and with the tips centered on the marks.

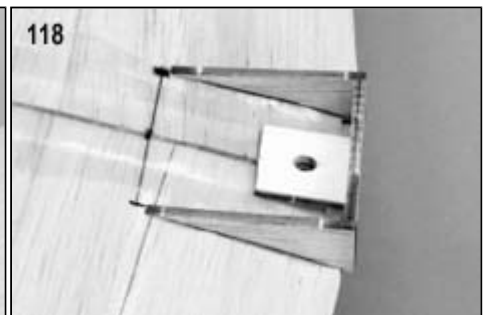

119. Taper the rounded end of the WFT top so it blends into the top of the wing and glue it onto the top of F-6T and onto the centerline of the wing.



120. Sand a 45 deg. angle along the sides of WFT to match former F-6T.

121. Fit and glue the WFC pieces onto the corners of the fairing by beveling the bottom to match the top of WFS and the wing skin.



122. Lay strips of masking tape along the sides of the WFSs to protect the wing skin and sand the excess off the top of the WFCs.

123. Run the 13/64" (5.3mm) drill back through the hole for the bolt and through the top of the fairing piece to mark the location of the wing hold down bolt. Install guide tube now, if desired.

124. Sand the fairing pieces flush to the rear of F-6T and bolt the wing onto the fuselage again. Now shape the fairing to blend into the rear of the fuselage.

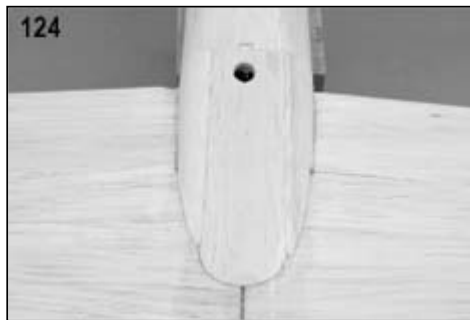

125. With scraps of 1/8"(3.2mm) balsa from the laser cut sheets fill between F-4T and the top of the wing and blend into the front of the fuselage over F-4 up to F-3T.

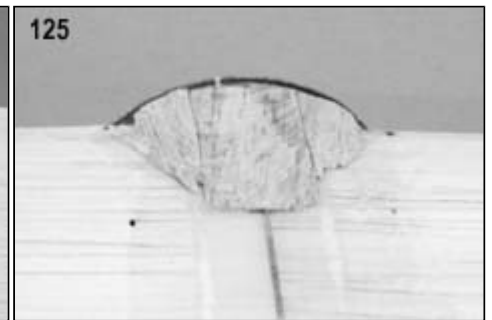

This completes the basic shaping of the wing and fuselage joint and now it is time to add the nacelles.

126. Install the servo wires for the speed controls and aileron servos at this time. You will need two 12" extensions for the speed controls and two for the aileron servos. Tie the plugs together in the center of the wing at the ends of a 6" piece of string to make sure you don't pull them up into the wing by mistake, while working on the nacelles.

127. On the bottom of the wing measure out 5-9/16" (141.3mm) from the centerline at both the leading edge and trailing edge and extend these marks until they are visible from the top of the wing. These are the centerlines that the nacelles are mounted on. From the nacelle centerline at the leading edge of each wing measure 1/4" (6.4mm) towards the wing tip and make a mark. From this mark measure 1-1/2" (38.1mm) towards the center of the wing and cut into the front of the leading edge at this mark 3/32" (2.4mm) deep. See Drawing.

Remove a tapered piece from the leading edge from the outboard mark to the bottom of this cut. This gives a flat spot on the leading edge for the top of N-2 to glue to.

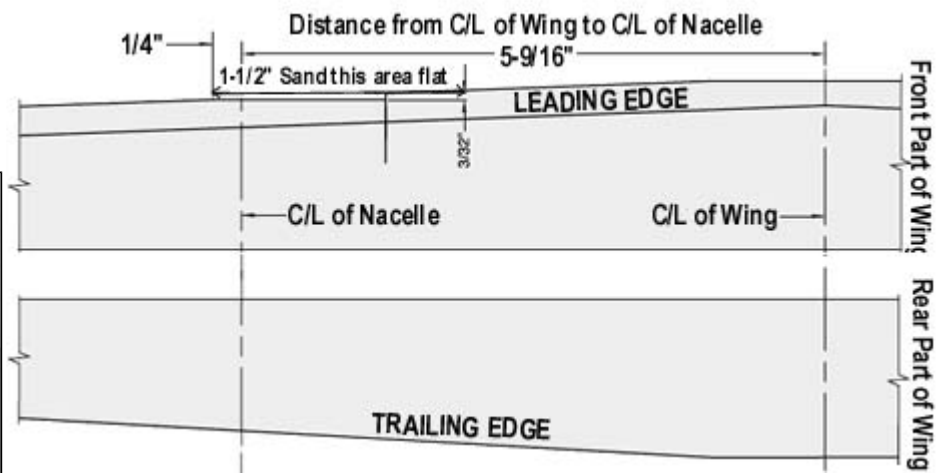

128. Mark the nacelles to identify left and right wing. Check the fit of each nacelle to its respective wing and correct if needed.
129. Mark the exact center of the nacelle on the rear of N-2 so it can be seen when it is fitted to the wing.
130. Thread the motor and esc wire through the holes in N-2 and N-1 then fit the nacelles to the bottom of the wing. Line up the centerlines at N-2 and the rear of the nacelles to the centerline marks on the wing, and if everything looks good, glue the nacelle to the wing.
131. Repeat on the other nacelle.
132. Bevel the bottom edge of N-7 to fit the nacelle sides then bevel the curved surface to fit the wing before gluing on the corners of the nacelles. There are four of these and each needs to be fitted individually.
133. When all the N-7s are glued in sand the tops down flush with the tops of N-1 and N-2 and back to the top skin of the wing. Taper the rounded end of N-8 until it blends into the curve of the top skin of the wing when sitting on the flattened off N-7s and glue down.

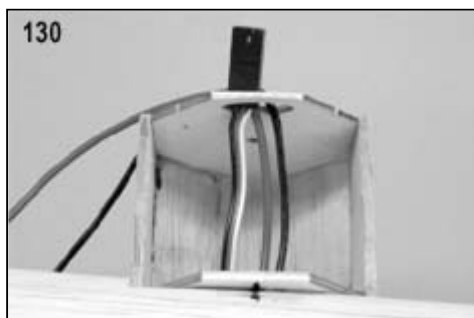

Glue triangular pieces of scrap on the top of the nacelles behind the trailing edge and blend into the wing skins and sides of the nacelles.

134. Lay down masking tape on the top skin next to the N-7s to protect the wing skin while the top of the nacelle is rounded off and blended in.
135. Finish sand the entire wing. Use your favorite filler on any imperfections and to radius the nacelle and wing fairing joints.



136. Since the pushrods to the tail are internal they need to be installed when the stabilizer is glued in. To make this job easier, cover stabilizer and elevators first. Then cut the hinge slots for the elevator and stabilizer, at the trailing edge of the stabilizer and the leading edge of the elevator. Cut the seven 1"x3/4" SIG Easy Hinges in half lengthwise, giving you 14 hinges measuring 1/2"x3/4". Make sure each hinge fits correctly, but do not glue the hinges yet. Use four here and set the rest aside for later.

### Installing Easy Hinges

SIG's famous Easy Hinges have been included in your kit to hinge all of the control surfaces. Each ultra-thin hinge is actually a three-part laminate - a tough plastic inner core sandwiched by an absorbent wicking material. The hinges have been chemically treated to slow down the reaction to thin CA glue (normally instant), to allow the glue time to soak all the way to the ends of the hinge and into the surrounding wood. Once the glue has set, the hinge cannot be pulled out of the structure without also tearing out the surrounding wood. All surfaces should be covered before hinging. Follow this hinging sequence for best results:

- Begin by inserting all of the required hinges halfway into the hinge slots in the trailing edge of the stabilizer. Carefully slip each exposed hinge end into its corresponding slot in the elevators.
- To set the hinge gap, deflect the elevators downward to the maximum amount of their movement while firmly holding the elevators to the trailing edge of the stabilizer. For best control response, the gap between the stab and elevators should be as small as possible but large enough to allow full, non-binding movement. Pieces of tape can be used to hold the elevators in the correct position to the stabilizer. Starting with one hinge, apply four small drops of THIN CA glue directly onto the exposed hinge at the centerline. The glue will wick into the slot as it penetrates both the wood and the hinge. Go to the next hinge and again apply four small drops of thin CA glue to the exposed hinge at the centerline. Repeat this process with the remaining hinges. Remove the tape holding the flexed elevators, allowing the elevators to return to their more or less neutral position.

- Turn the structure over and again flex the elevators downward and holding them in this position with pieces of tape. As you did with the top sides of the hinges, apply four small drops of thin CA glue to each of the hinges at the centerline. Remove the tape holding the elevators, allowing them to return to their neutral setting.
- Allow about ten minutes for the glue to fully wick and set. After this time has passed, flex the elevators up and down several times, through their full deflection. This should free up their movement. Continue flexing the elevators until they can be easily moved. Any excess CA glue can be easily removed with SIG Debonder.

137. In order to install the stabilizer, the top of the fuselage behind F-9 needs to be removed. Using a fine-tooth razor saw, cut vertically down through the top of the fuselage to the stabilizer slot, just behind F-9. Make the second cut slanted at a 45 deg. angle towards the front so that it comes out at the rear of the slot at the hinge line. Set this piece aside as it needs to be replaced later.

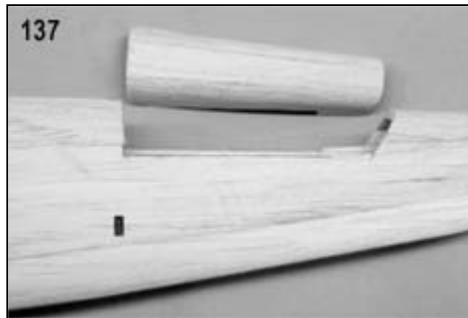

138. Bolt the wing in place as a reference to level the stabilizer. Set the stabilizer down into the slot, center and square it to the fuselage, then level to the wing, sanding the sides if needed to make it sit level. When all is square and level mark the covering at the sides of the fuselage and cut the part covered by the fuselage away for better glue joints. Also, make sure the rudder pushrod will clear F-9 and trim the bulkhead if needed. The elevators are now hinged in place to the stabilizer.

139. The elevator pushrod is now made. Remove the mounting flange from the aileron interplane horn and drill two 3/64" (1.2mm) holes as shown. Make two right angle bends on one end of a 1/32"x24" (0.8x610mm) music wire pushrod as shown.

Insert this wire into the two holes that were drilled with the long end of the wire in the hole farthest from the preformed end. Bend the long end 90 deg. towards the front and the short end to the rear to permanently lock the nylon horn onto the wire.

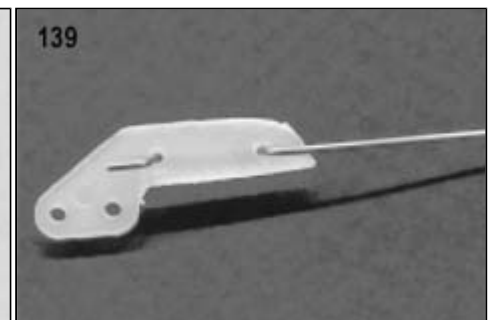
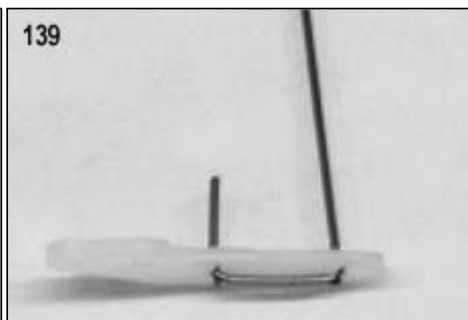
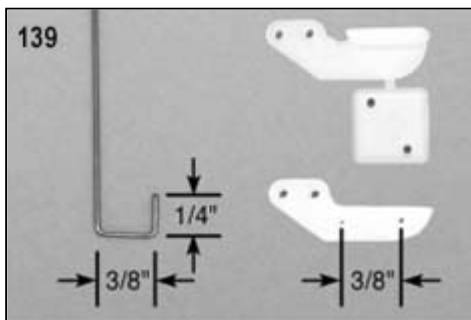

Slide this pushrod into its guide tube from the rear and make sure it moves freely.

140. Prepare the other 1/32"x24" (.8mm x610mm) music wire pushrod for the rudder by cleaning and sanding one end of the wire to prep for solder. Insert the cleaned end of this wire into the rudder pushrod tube from the servo end until it comes out of the stabilizer opening in the rear far enough so you can solder the rudder cable onto it. Be careful not to pull it completely out of the tube, as it is very difficult to reinsert it once the solder joint is made. Slip the 3/32" o.d. (2.4mm) brass solder coupler on the cleaned end of the wire, then slip the rudder cable from the stabilizer into the coupler along side of the wire. Verify that full travel can be obtained and solder together with STA-BRITE® silver solder. Trim off any excess wire and cable.



141. Set the stabilizer in place on the fuselage and check the rudder pushrod for freedom of movement. If you are satisfied with the freedom, lift the stabilizer part of the way out of its saddle and connect the elevator pushrod, reset the stabilizer and again check both controls for freedom of movement. You want to make sure these work properly now as they are going to be sealed in the fuselage permanently.



141. Square the stabilizer up again, then glue it to the fuselage.

142. Fit the fuselage top back over the stabilizer, trim the covering on the top of the stabilizer, then glue the top down. Sand and fill as needed to blend into fuselage top.

143. Fill-in any dents or dings as required, followed by finish sanding the fuselage.

144. Trim and trial fit the canopy at this time. The front of the canopy should be about 1/8" (3mm) behind the part line at the front of the hatch and the sides should be about even with the bottom of the hatch. Using the small circles punched out of the sides of MM-2 motor mount, fabricate and locate the canopy hold down block and sand to fit the canopy.

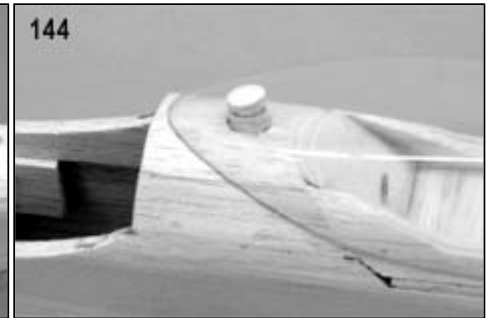
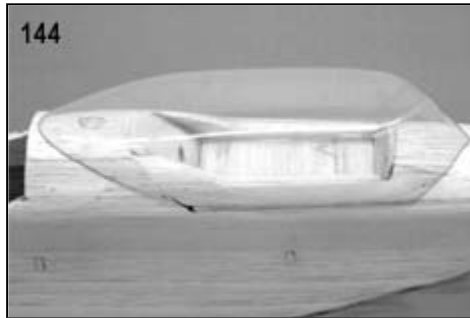

This mount should sit on a flat spot on the top of the fuselage centerline about 5/8" (15.9 mm) back from the part line at the rear of the hatch. Do not glue down or drill at this time.

144. Before finishing the cowls and engine mounts, notice that there is a small hole in the center of the firewall. This hole denotes the center of the thrust line and the center of the firewall. Draw two lines through the center of this hole, one horizontal and one vertical.

145. Remove a plywood cowl ring from sheet #11 and use it as a template to mark the location for the cowl hold down screws on the horizontal line after centering the ring from side to side.

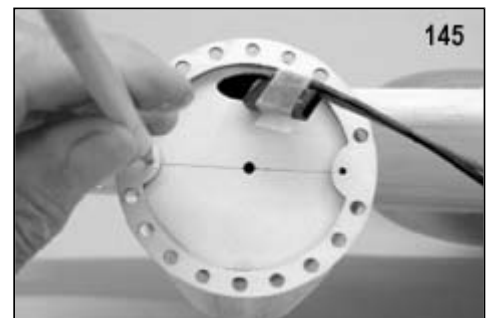

146. If you are going to use the included motor mount, you will also want to locate it's mounting screws on the vertical line at this time. The middle hole on the motor mount rear bulkhead MM-1 is the center of the thrust line and should be centered over the hole in the firewall. Pilot drill these 8 holes with a 3/64" (1.2mm) bit and apply a couple of drops of thin CA to each hole to harden the wood.

147. Trim the cowls to length and mark for the cowl ring. A handy tool for marking these accurately can be made from scrap wood. Follow the drawings and pictures on how to do this.

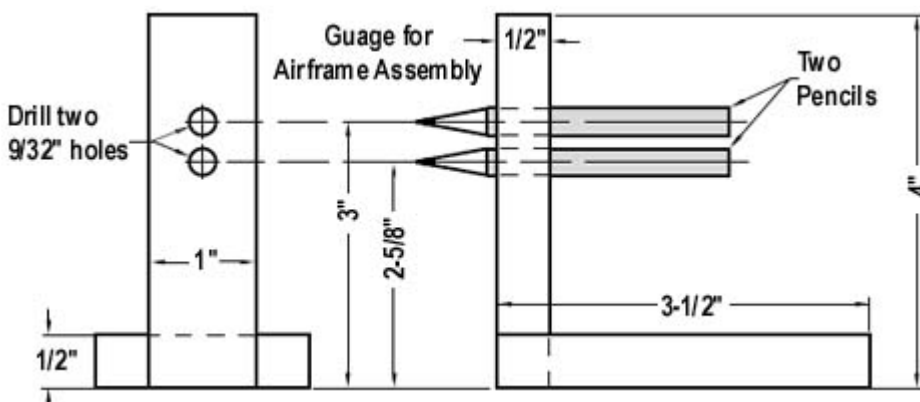

148. The cowl ring is inserted in the cowl until the rear of the ring just touches its line on the cowl. Glue this in with medium CA when it is properly positioned.



149. Cut out the front of the cowl, just inside of the lip, and open up and smooth the opening with sandpaper wrapped around a 1" diameter dowel.

149. The provided motor mount parts were designed for the FlyWARE REX220 brushless outrunner motor. However, they should fit most other 22 mm diameter motors, with little, if any, modifications. If you need to modify the front of the mount to fit your motor, it is easiest to do this now, before assembly. Assemble the mounts using the MM-1-2-3-4 parts as shown in the drawing.

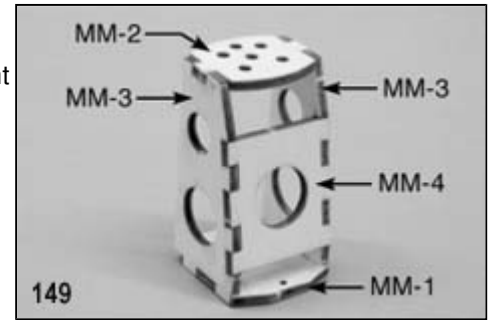

150. If you use a different type of mounting, be sure to center the thrust line on the centering hole on the firewall and allow 3-1/4" from the firewall to the rear of the prop.

151. Cover the vertical stabilizers, locate their position on the ends of the horizontal stabilizer, and remove the covering where they will glue together and for the rudder pushrods. Glue these on making sure they are vertical to stabilizer and the hinge lines are perpendicular to the same. Make sure the rudder pushrod does not get glued down.

152. Cover the rudders and hinge them to the vertical stabilizers.

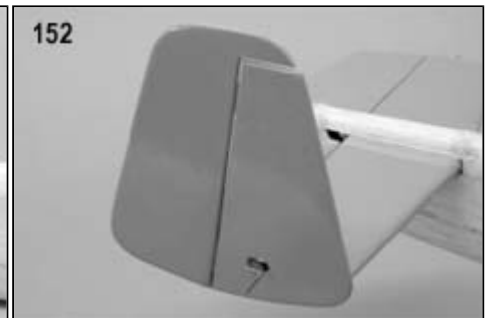
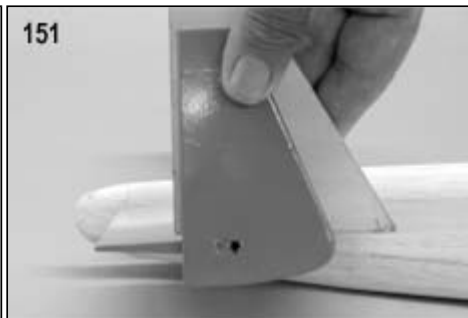

153. Finish covering the model in your chosen color scheme.

154. Detail the cockpit at this time. The instrument panel is copied from pictures of the full sized aircraft and is included on a separate sheet inserted in the manual. We like to line the cockpit floor and sides with colored construction paper to give the illusion of depth in this area.

155. Tape a piece of wax paper over the top of the fuselage so it covers up where you don't want the canopy to stick. Set the canopy in position and lightly mark where it crosses the hatch part line at the rear. Remove the canopy and apply a very small bead of epoxy on the inside of the edge from the front back to about 1/8" (3.2 mm) ahead of the part line, set the canopy in position on the hatch and tape it down until the epoxy cures. Be careful to avoid getting epoxy into the hatch part line, as this will make removing the hatch very challenging.

**COVERING TIPS:** It helps your covering job if you brush some SIG STIX-IT over the concave areas where you have formed fillets and other areas that have been filled. Also, brush some on other areas that are difficult to seal down such as wing leading and trailing edge overlaps, aileron leading and trailing edges and ends, center section fiberglass, and wing tip edges. Pre-cover the concave sections around the nacelles, the fuselage fairings at the center of the wings, and the stabilizer-fuselage joints with 1/2" (12.7mm) wide strips.

156. When the glue has cured, remove the hatch and cut away the covering where the hold down will glue down, then glue it down solid. Trial-fit the hatch and canopy back onto the fuselage and shape the disk until it matches the inside of the canopy. If the disk is not high enough to meet the canopy, add another disk and work from there.

157. Once you have a tight fit, drill through the canopy and through the center of the disk with 3/64" (1.2 mm) bit, remove the canopy and apply 4 drops of thin CA to the hole in the disk. A #2 x3/8" socket head sheet metal screw with a #2 washer can now be used to hold the hatch/canopy assembly down and allow easy access to the battery compartment. You can paint this disk to simulate radio equipment to help disguise it.

158. Clean the plastic cowls with soap and water and then dry. Lightly sand the cowls with #400 or finer sandpaper to break the glaze on the plastic. Just before you paint, wipe them down with alcohol. With this kind of preparation, most paints will cover nicely without primer. Since fuel is not a problem, acrylic paints can be used. Most craft stores have a huge assortment of colors to choose from in these paints in both flat and gloss tones. The canopy frames can be masked off and painted or the frames can be simulated with trim tape.



## FINAL ASSEMBLY AND RADIO INSTALLATION

159. Mount the aileron control horns with the inside edge of the horn 2-1/4" (57mm) out from the inner end of the aileron on a line perpendicular to the leading edge of the aileron. The front of the base plate should be 3/16" (4.8mm) back from the leading edge of the aileron.

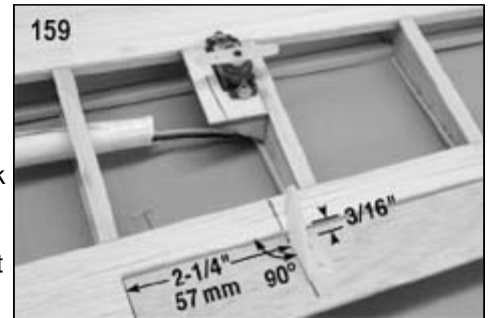

160. Trace around the base plate and remove the covering under the base plate. Mark the two holes for the screws and drill two pilot holes with a 3/64" (1.2mm) bit almost through the aileron. Using 5-minute epoxy or medium CA glue, glue the control horn to the wood and secure it with two #2 x7/16" sheet metal screws that have 3/32" (2mm) of the point filed off.

161. Hinge the ailerons to the wing using three SIG Easy Hinges for each aileron, as shown on the plans.

162. Plug an aileron servo into a pre-installed servo extension, tape or heat shrink the plugs together and feed this back down the paper tube to the hole in the center of the wing before screwing the servo into its mount. Repeat on the other wing. Connect the two leads together in the center with a short y-harness, then plug into the aileron socket of the receiver. Turn on your transmitter and receiver and center these servos before installing the servo arms pointing towards the center of the wing.

163. Bend two pushrods 2-13/16" (20.6mm) long from the pin of the r/c link to the Z-bend when the link is centered on the threads. Install the pushrods Z-bends in the center hole of the servo arms, the r/c link pin in the end hole of the control horn, check to make sure the ailerons move the right way and adjust for neutral.

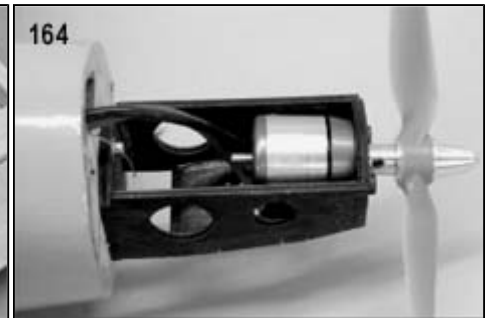

164. Install the motors on the mounts and the mounts on the firewalls and wire them up as required.

With brushless motors a speed control is needed for each motor. To keep the wires between the ESC's and the motors as short as possible, mount the ESC's out in the nacelles behind the motors. This also provides them with adequate cooling air. The servo extensions for the speed controls should already be available at the nacelles and they can be Y-harnessed together in the center of the wing. Check each motor for proper rotation before installing the cowls and props.

165. Secure the receiver in the compartment behind the servos. Stick on Velcro® works great for this task.

166. Install the rudder and elevator servos in the fuselage where shown, plug them into the receiver, and center them with the radio. Connect the push rods to the servos using the pushrod connectors in the inner hole of the servo arm. When connecting the rudder pushrod, tighten the connector in the center of the available pushrod travel. Use the 4-40 headless setscrews to clamp the wire in the connectors.

167. Fabricate the two rudder control horns from 1/8" (3.2 mm) dowel or 1/8"x3/16" (3.2x4.7mm) spruce and install the pushrod connectors as shown making a right and a left horn.

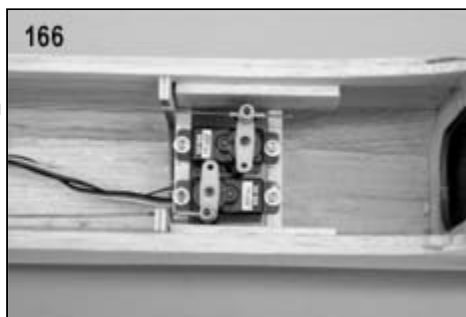

Clamp the rudders in neutral and center the rudder servo. Slide the right side connector onto the right rudder pushrod and move the assembly down to contact the rudder.

Note where the arm contacts the rudder, remove the covering from this spot, then securely glue the horn to the rudder and form a slight glue fillet around this joint.

Repeat on the left side. Tighten the setscrews on the connectors, remove the clamps holding the rudders, and then check for proper throw direction and travel. These rudders are very effective so not much travel is needed.

168. Because you will be connecting three different plugs whenever you mount the wing, it's a good idea to use small tape labels on the mating pairs for easy identification. Color electricians tape works great for this purpose.



## Decal Application

The decals supplied with your Do 217 kit are high quality Mylar® with an extremely aggressive adhesive. These are not die cut and must be removed from the sheet using a hobby knife and/or a sharp #11 blade or a sharp pair of scissors. We suggest the following method to accurately apply the larger decals in this kit.

- Carefully cut out the decal and lift it off the sheet with tweezers.
- Use a product like SIG Pure Magic Model Airplane Cleaner or Windex® to spray the area of the model that will receive the decal. Then spray the adhesive side of the decal as well.
- Lightly position the decal in place on the model. The liquid cleaner allows the decal to slide easily into the desired position as long as you don't press down on it.
- Once you have it in position, hold the decal lightly in place with your fingertips and use a paper towel to gently dab away the excess liquid.
- Use a small squeegee to now set the decal in place, removing all excess liquid and any trapped air bubbles from beneath the decal. The SIG 4" Epoxy Spreader (SIGSH678) is ideal for the job.
- Remove any excess fluid with a paper towel and allow the decals to set overnight. They will be solidly adhered to the model without any air bubbles.

## Option Safety Tip

For safety and convenience we like to install a master switch in the battery harness between the drive batteries and the ESC's. This must be accessible from the outside of the airplane to be effective.

## Control Throws

Mount the wing to the fuselage with all connectors plugged into the receiver and battery harness. Check to make sure all wiring is inside the fuselage and not caught between the wing and fuselage saddle. Install the battery pack in it's compartment in the nose and turn the system on and verify that everything moves the proper direction and the control throws are within the suggested range.

|          |              |                |
|----------|--------------|----------------|
| Ailerons | 3/8" (9.5mm) | Up and Down    |
| Elevator | 1/4" (6.4mm) | Up and Down    |
| Rudders  | 1/4" (6.4mm) | Left and Right |

## Center Of Gravity

With the wing installed and the battery in place, the center of gravity should be checked and adjusted as required. The airplane should balance 2-3/4" to 3" (70 to 76.2mm) behind the leading edge of the wing at the root.

## FLYING

The SIG Do 217 is actually quite easy to fly, provided you've had previous experience and success in flying R/C models in the past. This model is not recommended as an R/C trainer. If this is your first R/C model aircraft, we urge you to seek out and use an experienced R/C pilot to pre-flight, test fly, and flight-trim the model for you. The Do 217 is very stable and provides excellent control response. If your model was built without landing gear, you will, of course, have to hand-launch it. The very best conditions for your first test flights would be with no wind, such as in the morning or evening. Not having to deal with windy conditions allows you to properly observe and trim your model without undue influence from winds. Properly powered, the Do 217 is certainly capable of flying in moderate winds without issue. But for the first trim flights of this or any model, we always suggest choosing a day with little or no wind.

Before making the first test flight, take the time to make sure each of the flight control surfaces are moving in the correct directions and are properly centered. Once you're certain that they are, check these controls, once again. Next, holding the model securely, throttle-up the motors to make sure they're reaching full power and sound in "synch". The propellers should be balanced and free of dings and nicks - never fly your model with propellers that are damaged in any way! Finally, we strongly suggest that you perform a range check of your radio system using the range test criteria spelled out in the instructions that came with your particular radio system.



With everything now checked, double-checked, and working properly, you should be ready to commit to flight. With one hand, hold the model by its belly, just below the wing saddle, while holding your transmitter in your other hand. Face directly into the prevailing wind direction and advance the throttle stick to approximately 2/3's power. Take a few brisk steps forward and launch the model straight ahead, giving it plenty of flying speed, while keeping the wings level and the nose pointed directly at the horizon. Never launch the model with the nose up or with one wing lower than the other!

Doing this has the potential of inducing a stall condition that, in turn, could cause the airplane to crash due to lack of airspeed. If, for whatever reason, you feel that you cannot make a successful hand launch by yourself, ask a flying buddy to launch the airplane for you. Just be sure that he completely understands what you want him to do - wings level, nose pointed at the horizon, and a good hard launch.

The airplane should smoothly leave your hand launch and fly quickly away in a slight climb. Add a little more power and continue flying the airplane directly upwind while gaining speed and altitude. Once the model is at a reasonable trimming altitude, begin the trimming process, with the transmitter trims to achieve straight and level flight at about the 2/3's throttle setting. Once the model is trimmed to your satisfaction, you can begin to explore it's flight envelope.

One of the first things that we always like to check out on any new model is the stall characteristic. At altitude, hold the model in a level upwind heading and begin throttling back the motors, while gradually adding up elevator input to maintain altitude. The goal here is to observe what the model does when it becomes fully stalled and to also learn the approximate speed and attitude it's in when the stall occurs. Our prototype Do 217 models demonstrated fairly clean stalls, with the nose dropping forward and controlled flight resuming shortly thereafter. This is very good information to have when it comes time to set-up the landing.

We have found with our Do 217 prototypes that the roll authority is quite good using the suggested aileron movements in this manual. With practice, the rolls can be made almost axial with judicious elevator input. But the type of roll that we really prefer with this model is the more rounded "military" type roll - these just look great!



If your own Do 217 is powered with the brushless motors suggested in this manual, it should have plenty of power. This means that loops can be made from level flight and can actually be quite large. Also, despite the relatively small amount of available rudder throw, the Do 217 can also make some impressive flat turns. We have also induced our prototypes into some very nice looking spins and have had no problem at all, stopping the spin exactly when we wanted to by neutralizing the controls.

You should also find that your Do 217 model will fly inverted very comfortably, but will likely require some down elevator input to maintain level flight. We have even done outside loops with our prototypes and even though these are far from being prototypical to the full-size aircraft, they do look very cool.

In all of this, there is one maneuver that you will probably never get tired of, and that is the long, low fly-bys. Man, does this airplane ever look the part when flown in high or low-speed, low-level passes!

Landing the Do 217 is almost a non-event. Assuming, of course, that you're flying off of a grass field, the set-up for a landing approach is no different than any other model. Pick a point on the field where you want to touch down and fly the airplane down to that point, slowing it up by throttling back. Like any other landing approach, start with the downwind leg, followed by the base turn and last, the turn to the final upwind landing approach to your runway. This sequence is ideally flown with the model gradually descending to final touchdown with the wings level. Just before touchdown, the throttle stick should be fully off with no power to the motors and the airplane will slide cleanly to stop.

After the first test flight, review the transmitter trim inputs and adjust the flying surface linkages accordingly. Then return the transmitter flight trims to their neutral settings. You may have to do this a couple of times until the airplane is completely "dialed-in" to your liking. Also, after each flight, make it a habit to inspect the airplane completely - inside and out - for anything that may have come loose, may have broken, etc. This simple practice will keep your Do 217 on the ready line for a long time to come.

We sincerely hope that you have enjoyed building and flying your new SIG Do 217 model. We also hope that you will continue to fly it safely for a long time to come, with respect for other people and property.

**Good luck and safe flying!**

SIG Manufacturing is completely committed to your success with this model. If, for any reason you should encounter any problems with the parts or materials used in this kit, be sure to contact SIG.

**Warning! This is not a toy!**

Flying machines of any form, either model-size or full-size, are not toys! Because of the speeds that airplanes must achieve in order to fly, they are capable of causing serious bodily harm and property damage if they crash. IT IS YOUR RESPONSIBILITY AND YOURS ALONE to assemble this model airplane correctly according to the plans and instructions, to ground test the finished model before each flight to make sure it is completely airworthy, and to always fly your model in a safe location and in a safe manner. The first test flights should only be made by an experienced R/C flyer, familiar with high performance R/C aircraft.

The governing body for radio-control model airplanes in the United States is the ACADEMY OF MODEL AERONAUTICS, commonly called the AMA. The AMA SAFETY CODE provides guidelines for the safe operation of R/C model airplanes. While AMA membership is not necessarily mandatory, it is required by most R/C flying clubs in the U.S. and provides you with important liability insurance in case your R/C model should ever cause serious property damage or personal injury to someone else. For more information, contact:

**ACADEMY OF MODEL AERONAUTICS**  
**Telephone: (765) 287-1256**

**5161 East Memorial Drive**  
**Muncie, IN 47302**

SIG MFG. CO., INC. is totally committed to your success in both assembling and flying the Dornier Do 217 kit. Should you encounter any problem building this kit or discover any missing or damaged parts, please feel free to contact us by mail or telephone.

**SIG MFG. CO., INC.**

**401-7 South Front Street**  
**Montezuma, IA 50171-0520**

SIG MODELER S ORDERLINE: (to order parts)

1-800-247-5008

SIG MODELER S HOTLINE (for technical support)

1-641-623-0215

SIG WEB SITE

[www.sigmfg.com](http://www.sigmfg.com)

© Copyright SIG Mfg. Co., Inc.

**SIG MFG. CO., INC.....Montezuma, Iowa 50171-0520**

**LIMIT OF LIABILITY:** The craftsmanship, attention to detail and actions of the builder/flyer of this model airplane kit will ultimately determine the airworthiness, flight performance and safety of the finished model. SIG MFG. CO's obligation shall be to replace those parts of the kit proven to be defective or missing. The user shall determine the suitability of the product for his or her intended use and shall assume all risk and liability in connection therewith.