



FAIRCHILD 24



Herr Engineering Corp. HRR102



ASSEMBLY INSTRUCTIONS

Your kit contains the following parts. Please check your kit for any missing or damaged parts before starting construction.

COMPLETE KIT PARTS LIST			
1	Plan Sheet #1	1	Plan Sheet #2
1	White Tissue	1	Colored tissue
1	Tailwheel Assy.	3	Plastic Windshield Material
11	3/32" sq.x18" Balsa Strip	2	1/8" sq.x18" Balsa Strip
4	3/32"x1/4"x18" Balsa Strip	1	3/16"x2" Birch Dowel
1	Plastic Propeller	1	Propeller Shaft
1	Nylon Propeller Bearing	2	Plastic Wheels
1	3/16"x60" Rubber Strip	8	Laser Cut Sheets
		1	Decal Sheet
		1	1/16"x12" Landing Gear Wire
		22	1/16" sq.x18" Balsa Strip
		5	3/32"x3/16"x18" Balsa Strip
		1	Instruction Manual
		2	Brass Washer
		2	1/16" Plastic Wheel Retainers

Tools and Building Supplies

You will need the following items to assemble this model. You must read and follow all of the manufactures instructions provided with these items!

-Glue	CA, White Glue, Siment or Ambroid all work well.
-Cutting Tools	A hobby knife with a #11 blade is used for general cutting. A single edge razor blade is also a useful cutting tool.
-Clear Dope, Thinner & paint brush	
-320 and 400 grit sandpaper	
-Straight Pins	
-Wax Paper	
-Needle nose pliers	
-1/4" Drill Bit	
-Building Board	

The first thing that you need to do is to identify and mark the part numbers on the laser cut parts using the drawings on the following pages as a guide.

It is possible that several of the laser cut parts may not be completely cut through. If this is the case you can free the part from the sheet quickly using an X-acto knife.

NOTE: The slight discoloration on the edges of the laser cut parts may be removed by lightly sanding the edges with 400 grit sandpaper.

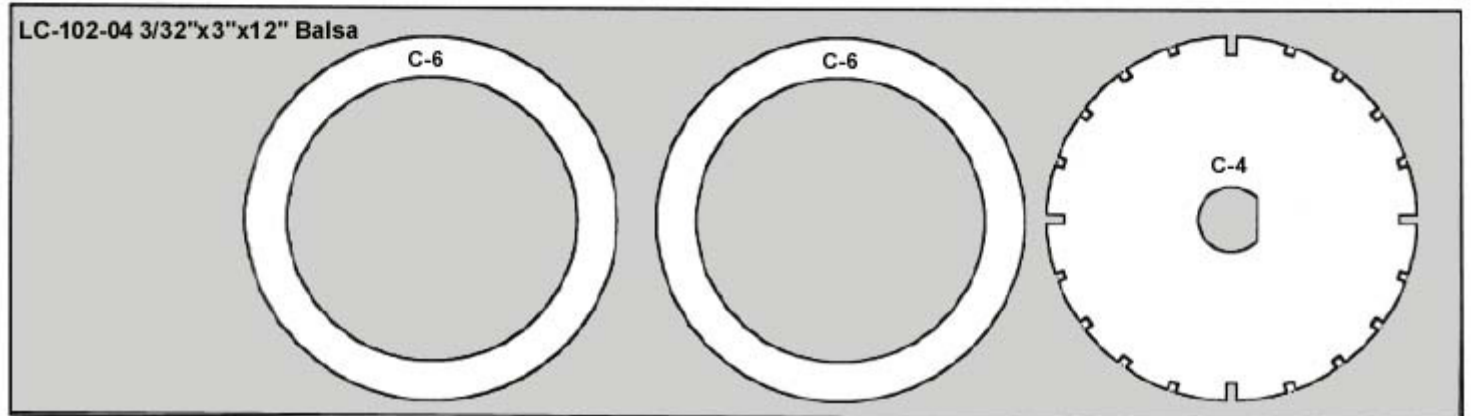
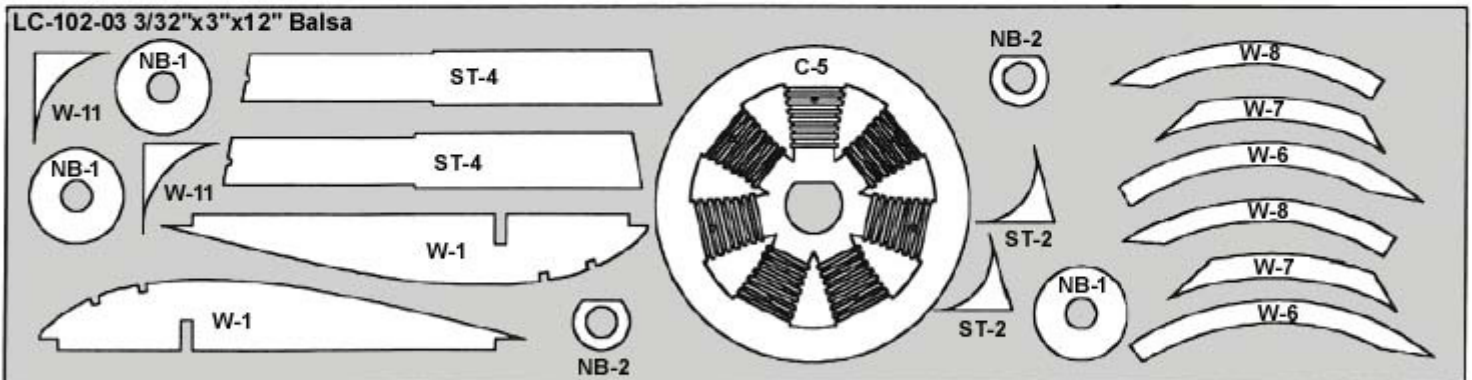
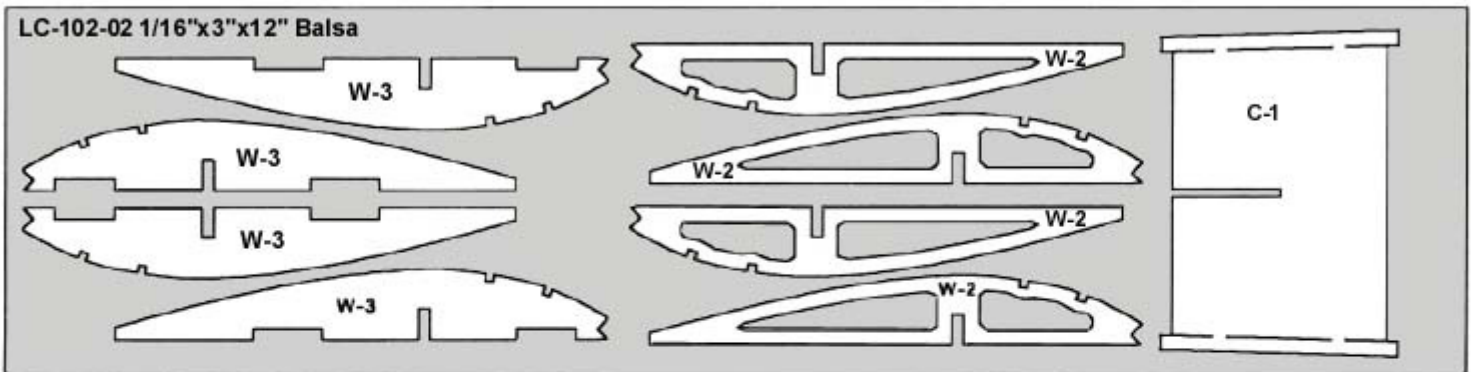
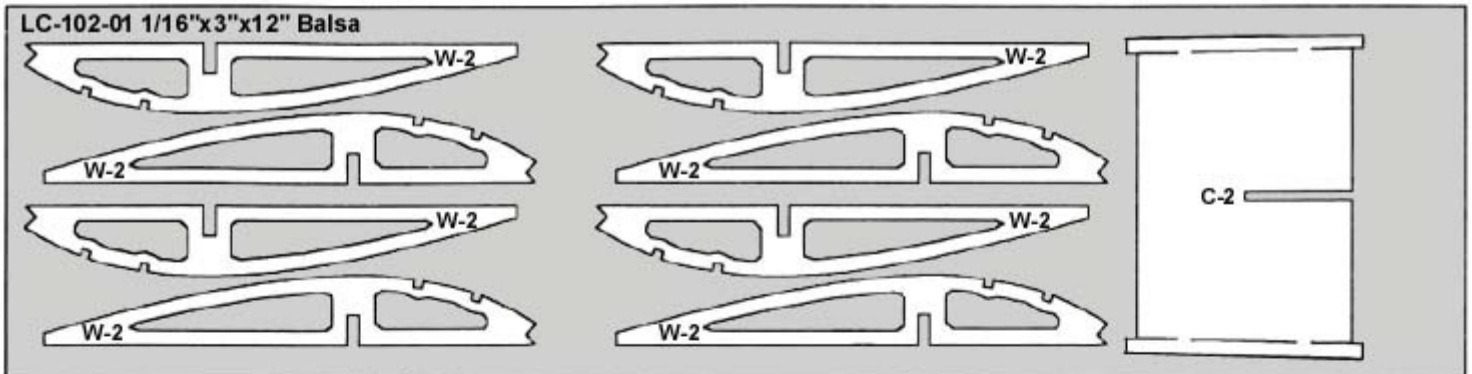

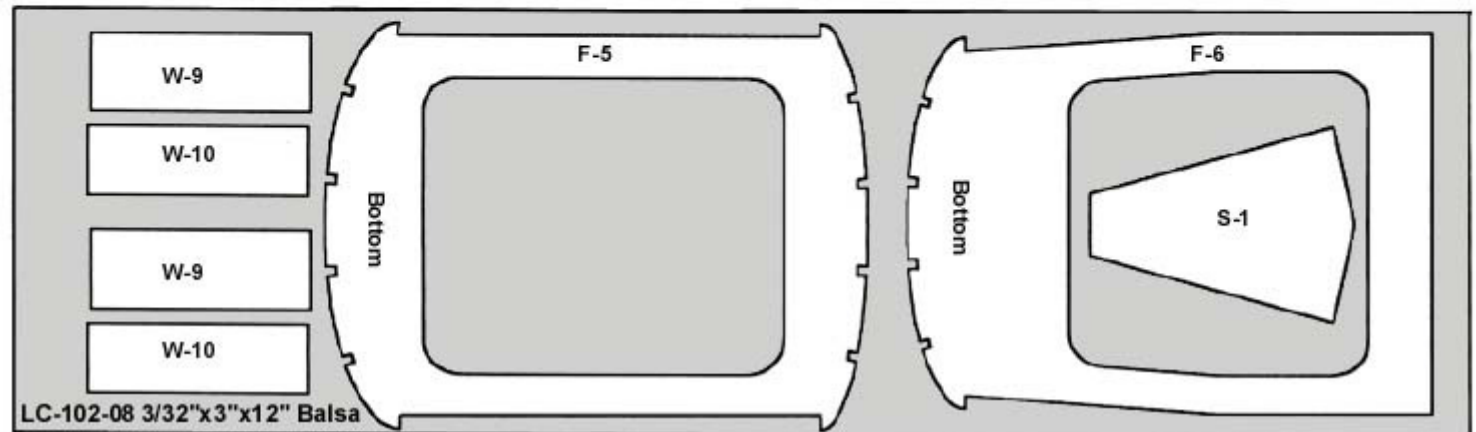
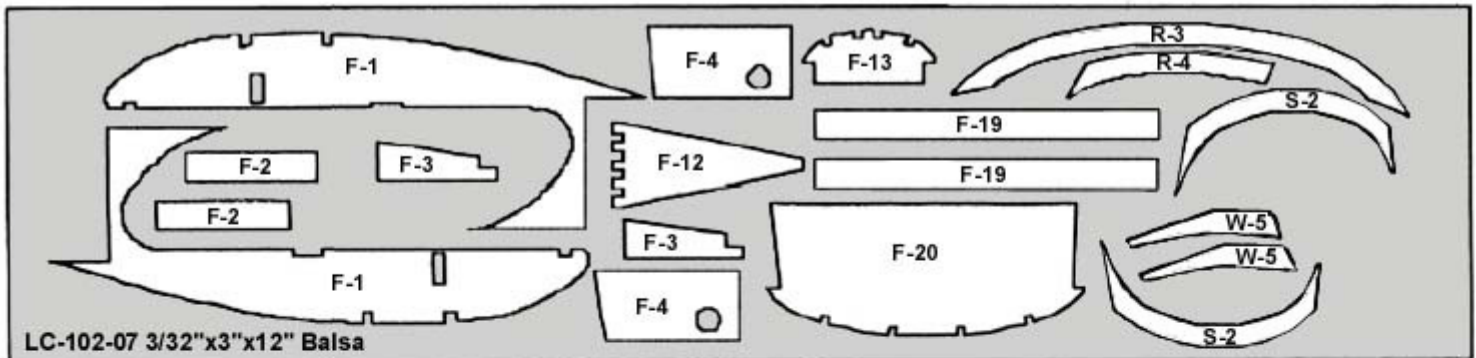
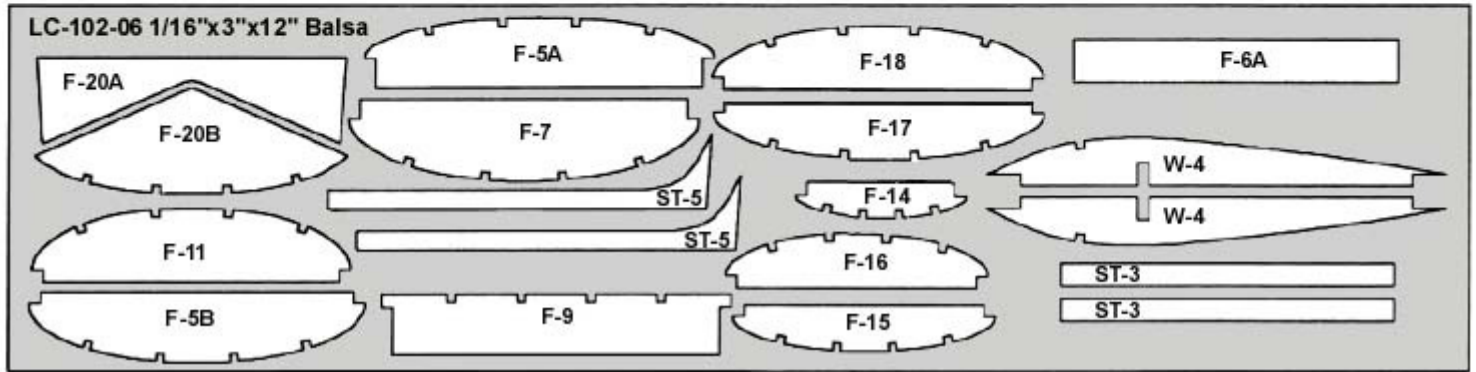
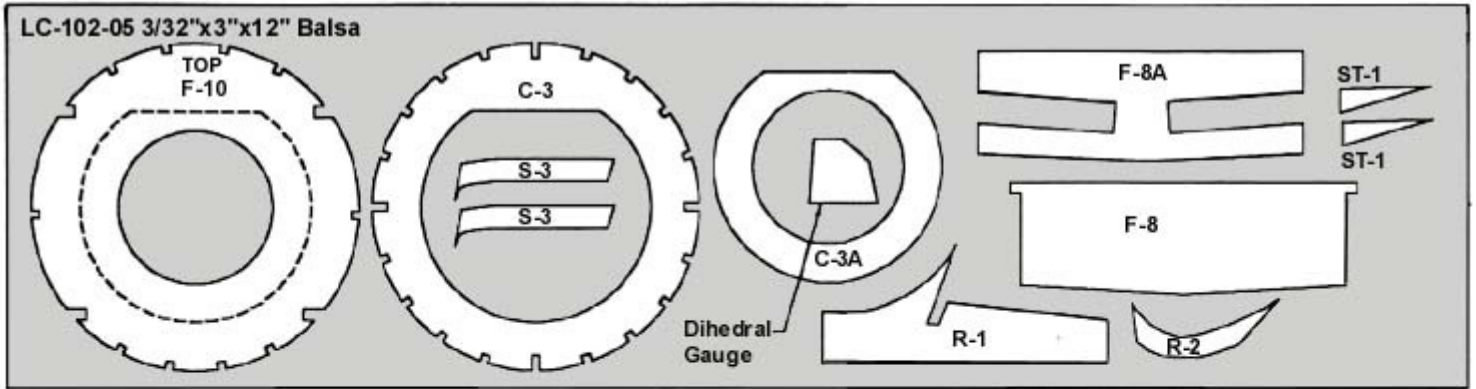

Beginners Note

These instructions were written assuming that the builder has previous building experience. If this is your first model then we recommend that you purchase a copy of the following book:

Rubber Powered Model Airplanes By: Don Ross

This excellent book covers basic building and flying procedures and provides valuable information about all aspects of building and flying rubber powered model airplanes.

Building the Tail Surfaces

1. Cover the plan with wax paper.
2. Build the Rudder from laser cut parts R-1, R-2, R-3 and R-4. The remaining rudder structure is made from 3/32"sq. balsa strip.
3. Build the Stabilizer from laser cut parts S-1, S-2 and S-3. The leading edge and trailing edges are made from 3/32" x 3/16" balsa strip. The remaining stabilizer structure is made from 3/32" sq. balsa strip.
4. Sand the tail surfaces smooth and round the edges. Set the tail surfaces aside until needed later.

Building the Fuselage

5. Build the fuselage sides over the plan using the laser cut parts F-1, F-2, F-3 and F-4. The remaining pieces of the side frames are made from 3/32" sq. balsa strip.
6. Glue F-5A and F-5B to the top and bottom of F-5.
7. Glue F-6A to the top of F-6.
8. Glue F-5 onto one of the fuselage sides. Use a small square to assure that F-5 is 90 degrees to the fuselage side.
9. Glue F-6 onto the fuselage side as you did F-5.
10. Glue the opposite fuselage side into position carefully making sure that the fuselage is held square.
11. Glue F-7 into position.
12. Glue F-8A to F-8.
13. Glue F-8 into position on the fuselage. Be careful not to cover the spar slots in the F-1's.
14. Glue F-9 into position.

NOTE:

You can build either the Radial engine version 24W or the Ranger inline engine version 24R. You must decide at this time which version you want to build. The wood for the 24R version is not provided in the kit.

15. If you want to build the radial engine version, glue F-10 into position on the front of the fuselage. If you want to build the Ranger 24R version, Trim F-10 to the shape shown on the plan and then glue into position on the front of the fuselage.
16. Glue F-11 into position and add the five 1/16" sq. balsa stringers in place.
17. Bevel the inside edges of the rear fuselage sides as shown on the plan.
18. Glue the rear fuselage sides together with F-13 and F-14 temporarily in position. Make sure that the aft fuselage is straight and square before gluing.
19. Now glue F-12, F-13 and F-14 into position.
20. Glue F-15, F-16, F-17 and F-18 into position on the fuselage.
21. Glue the center two 1/16" sq. balsa stringers between F-9 and the tail on the top of the fuselage. Be sure to maintain a 3/32" wide gap between the two stringers at the aft end. The rudder needs to fit between these stringers.
22. Glue the remaining two 1/16" sq. balsa stringers to the aft top fuselage.

23. Glue the two F-19 pieces to the front top of F-6. When the glue is dry, sand the F-19's flush with the F-1's on the fuselage sides.
24. Glue F-20A and F-20B to the rear of F-20. Bend the landing gear wire using the pattern on the plan. Glue the landing gear wire into the slot between F-20A and F-20B. Make sure to attach the wire so that the landing gear angles forward as shown on the plan.
25. Glue the landing gear assembly to the front of F-6.
26. Glue the 1/16" sq. balsa stringers to the bottom of the fuselage between F-10 and F-12.
27. Glue the 1/16" sq. stringer to the fuselage side between F-10 and F-5. The outside face of the stringer should be flush with the outside of the fuselage side.
28. Make the windshield braces from 1/16" sq. balsa strip and glue into position as shown on the plan.
29. Glue C-3A to the front of F-10.
30. Pin C-3 to your building board and glue parts C-1 and C-2 into position carefully at the ends only.
31. Glue C-4 to the front of C-1 and C-2. The flat edge of the hole in the center should be aligned with the flat edge on the hole in the center of F-10.
32. Carefully cut the centers of C-1 and C-2 away.
33. Add the 1/16" sq. balsa stringers to the cowl.
34. Carefully glue C-5 and the two C-6's to the front of the cowl.
35. Sand the front lip of the cowl to the shape shown on the plan. Sand the cowl smooth all over and glue it to the front of the fuselage.
36. Assemble the removable nose block from two NB-1's and two NB-2's.
37. Adjust the center hole to establish the proper down thrust and right thrust and then assemble the propeller assembly and test fit to the front of the model.
38. Sand the fuselage smooth all over.
39. Cut the tail post away at the rear end of the stabilizer slot.
40. Cut and test fit the windshield.
41. Test fit the tail surfaces to fuselage.
42. Set these parts aside until needed later.

Building the Wings

43. Pin the 3/32" x 1/4" balsa spar to the plan. Pin W-5 in place over the plan. Pin the 3/32" x 1/4" balsa trailing edge into position over the plan. Pin W-9 and W-10 into position.
44. Pin W-1 into position. Use the dihedral gauge to angle the rib toward the wing tip and then glue W-1 into position.
45. Glue the six W-2 ribs into position 90 degrees to the building board.
46. Glue the two W-3 ribs into position.
47. Glue the 1/8" sq. leading edge into position.

48. Glue W-6, W-7 and W-8 together over the plan.
49. Raise the tip 3/32" from the building board at the tip and glue the tip to the leading edge and trailing edge.
50. Glue W-4 into position.
51. Glue the two 1/16" sq. balsa leading edge spars to the top of the wing.
52. Remove the wing from building board and sand smooth and round the leading edge and wing tip.
53. Build the opposite wing as you did the first.
54. Test fit the wings to the fuselage.
55. Assemble the wing struts over the plan and test fit now.

Cover the Model

56. Sand the entire model smooth with 400 grit sandpaper.
57. Coat the exposed surfaces with two coats of clear dope.
58. Attach the tissue to the model with clear dope mixed 50/50 with thinner.
59. Lightly mist the model with water to shrink the tissue.
60. Apply two coats of thinned dope to the entire model.
61. Carefully apply the waterslide decals to the model.
62. Draw additional details on the model with a waterproof marker and paint the motor detail.

Final Assembly

63. Glue the windshield and side windows into position on the model.
64. Glue the wings into position on the model.
65. Test fit, sand, finish and glue the wing struts into position.
66. Sand, finish and glue the two ST-3's into position.
67. Fit, finish and attach the two ST-5's.
68. Trim and finish the two ST-4's to fit in position as shown on the plan. Glue a portion of a straight pin into the top front of the ST-4's.
69. Glue the ST-4's into position at the lower end only using clear silicone rubber. The top ends attach to the wing struts by pressing the pin into the strut. Do not glue this end. It will release on a hard landing.
70. Test fit and glue the stabilizer to the rear fuselage being careful to maintain proper alignment.
71. Glue the rudder to the fuselage accurately.
72. Glue the propeller assembly into the removable nose block.
73. Tie and install the rubber motor using the 3/16" dowel at the rear end to retain the rubber motor.
74. Balance the model at the point shown on the plan. Add weight to the nose or tail as required to achieve the proper balance.

75. Your model is now complete. You MUST READ AND FOLLOW all of the safety rules. We hope that you have enjoyed assembling your model and hope that you enjoy many fine flights.

Your First Flights

1. Make sure that all flying surfaces are straight and warp free.
2. Wind the motor about 100 turns.
3. Point the nose of the model into any gentle breeze that may be blowing.
4. Release the propeller and after it starts turning gently toss the model aiming the nose at a point on the ground 100' in front of you. Adjust the model to circle while increasing the number of turns in the motor. Adjustments can be made by gently bending the tail surfaces and wing trailing edge.
5. A properly trimmed model will circle to the left while climbing under power, level out as the power runs down and transition into a right hand gliding circle.

Safety Rules

1. Fly your model in a large open area that is free of obstructions, people or their property.
2. Do not fly your model in the vicinity of power lines, trees, streets or buildings.
3. Never try to retrieve any model stuck in power lines, in trees or on a roof or other high place.
4. Position yourself at least 150' from spectators before launching model.
5. Never launch model directly at another person or other object.
6. Never stick your fingers into a spinning propeller. Do not try to stop a spinning propeller with your hand or fingers. Never stick any object into a spinning propeller.
7. Fly your model only on calm days. Do not fly when the wind is blowing.
8. Get proper permission before retrieving your model from private property.

WARRANTY

Herr Engineering Corp. guarantees this kit to be free from defects in both materials and workmanship at the time of purchase. This warranty does not cover any component damaged by use or modification. In no case shall Herr Engineering Corporation's liability exceed the original cost of the purchased kit. Further Herr Engineering Corp. reserves the right to change or modify this warranty without notice.

In that Herr Engineering Corporation has no control over the assembly or use, no liability shall be assumed or accepted for any damage resulting from the use by the user during construction of the kit or the use of the final user assembled product. By the act of building this kit and/or using the final user assembled product, the user accepts all liability.

If the buyer and/or user is not prepared to accept all of the liability associated with this product, he is advised to immediately return this kit in new and unused condition to the place of purchase for a full refund.

LIMIT OF LIABILITY:

In use of our products, Sig Mfg. Co.'s only obligation shall be to replace such quantity of the product proven to be defective. User shall determine the suitability of the product for his or her intended use and shall assume all risk and liability in connection therewith.