

BIKE 2022 / EN

SPECS LIST + GEOS

DOWNHILL

Summum Carbon RR / Summum Carbon R
Summum R / Summum

SUPER ENDURO

Superfoxy Carbon RR / Superfoxy Carbon R
Superfoxy R / Superfoxy

XC RACE

F-Podium DC RR / F-Podium DC R / F-Podium DC
F-Podium R / F-Podium
Podium RR SL / Podium R / Podium

XC PRO

Chrono Carbon RR / Chrono Carbon R / Chrono Carbon
Chrono R / Chrono

e-MTB ENDURO

Dusk RR / Dusk R / Dusk
Chaser

e-MTB TRAIL

Prime 29 / Prime + / Prime X
Thundra / Thundra X

KIDS

Factor 26 / Factor 24
Leader 26 / Leader 24 / Leader 20 / Leader 16

e-MTB KIDS

F-Play 26 / F-Play 24 / Play 26 / Play 24 / Play 20
Grommy 16 / Grommy 12



DOWNHILL

SUMMUM CARBON RR

Matte Carbon UD / Gloss Racing Silver

FRAME	Summum Carbon Stealth Air full Carbon, Zero Suspension System, 200mm travel, Forward Geometry, Carbon Monoblock upper link, SuperBoost 12x157mm rear axle, 83mm BSA bottom bracket, HHG internal cable routing, MAX. capacity dual raw Enduro bearings, shock mudguard, ISCG 05, custom frame protectors. *Geometry kit included
SIZES	S / M / L / XL 29" and MX
REAR SHOCK	Fox DHX2 Factory Kashima, 225x70mm. Settings: high and low-speed compression, high and low-speed rebound, spring preload. Super light steel (SLS) spring. Trunnion top mount, 30x8mm bottom bushings
SHOCK SETTINGS	ECC010 compression, ECR012 rebound. Spring rate: S size 400 lbs, M size 450 lbs, L/XL size 500 lbs
FORK	Fox 40 29 Float FIT GRIP2 EVOL Factory Kashima, 203mm, air spring, 1-1/8" steerer tube, 20x110mm axle, offset 56mm. Settings: high and low-speed compression, high and low-speed rebound, air preload
HEADSET	Onoff Mercurium 1.5 ZS for 1-1/8" steerer tube, 41x30.15x7x45°x45° ACB sealed bearings, geometry kit cups, external diameter 56mm
STEM	Onoff Krypton DH CNC Integrated FG, 25-30mm adjustable length, 31.8mm barbore, 6061 alloy, 2x6mm spacer
HANDLEBAR	Renthal Fatbar series 7 alloy, rise: 30mm, width: 800mm, 7° backsweep, 5° upsweep, 31.8mm barbore
GRIPS	Renthal, double lock-on, kevlar compound, 130mm
SEATPOST	SDG Micro I-Beam SP-951 Carbon, diameter 31.6mm, length 300mm, micro-adjustment
SADDLE	SDG I-Fly 2.0 I-Beam, high-density PU foam, Cordura sides
FRONT BRAKE	Shimano Saint M820, 4-piston caliper, RT86 203mm 2-piece IS 6 bolts rotor with ICE technology, resin pads with cooler
REAR BRAKE	Shimano Saint M820, 4-piston caliper, RT86 203mm 2-piece IS 6 bolts rotor with ICE technology, resin pads with cooler
BRAKE LEVER	Shimano Saint, ergonomic antiskid lever with servo wave, free stroke and tool less reach adjust
RIMS	e*thirteen LG1 Race Carbon, IW30 29" Hookless, World Cup carbon fiber, 30mm internal width, tubeless ready, 32 spokes
SPOKES	e*thirteen custom Hive triple-buttet black alloy, alloy nipples, nipple washers
FRONT HUB	e*thirteen Boost 20x110mm, triple-sealed, fully machined aluminum, IS 6 bolts
REAR HUB	e*thirteen Superboost 12x157mm, triple-sealed, fully machined aluminum w/6-degree engagement, IS 6 bolts

FRONT TIRE	Michelin DH34 29x2.4, tubeless ready, Magi-X DH compound, double-reinforced DH shield casing, wire bead
REAR TIRE	Michelin DH34 29x2.4, tubeless ready, Magi-X DH compound, double-reinforced DH shield casing, wire bead
CRANKSET	Shimano Saint M825 Hollowtech II, reinforced steel axle, 165mm
RINGS	36T, aluminum, BCD 104
BOTTOM BRACKET	Shimano 83mm
PEDALS	---
CHAIN	Shimano HG95, 10s
FRONT DERRAILLEUR	E.13 LG1+ Race Carbon chain guide, IFD DMB (Direct mount Bashguard) Gen 2 Stealth Idler, Aluminum hardware, adjustable/replaceable lower armature, polycarbonate, ISCG 05, adjustable upper slider
REAR DERRAILLEUR	Shimano Saint RD-M820-SS, 10s, Shadow+, short cage
SHIFT LEVERS	Shimano Saint SL-M820 10s, low friction multi bearing, instant release, multi release, 2-way release
CASSETTE	Shimano CS-HG500-10, 11-25T, 10s
DERAILLEUR HANGER	---
OTHERS	*Geometry kit included: +-1° / +-2° headset cups
WEIGHT	---



DOWNHILL

SUMMUM CARBON R

Matte Carbon UD / Gloss Frost Green / Yellow

FRAME	Summum Carbon Stealth Air full Carbon, Zero Suspension System, 200mm travel, Forward Geometry, Carbon Monoblock upper link, SuperBoost 12x157mm rear axle, 83mm BSA bottom bracket, HHG internal cable routing, MAX. capacity dual raw Enduro bearings, shock mudguard, ISCG 05, custom frame protectors. *Optional Geometry kit
SIZES	S / M / L / XL 29" and MX
REAR SHOCK	Fox DHX2 Performance Elite, 225x70mm. Settings: low-speed compression, low-speed rebound, spring preload. Trunnion top mount, 30x8mm bottom bushings
SHOCK SETTINGS	ECC010 compression, ECR012 rebound. Spring rate: S size 400 lbs, M size 450 lbs, L/XL size 500 lbs
FORK	Fox 40 29 Float FIT GRIP EVOL Performance, 203mm, air spring, 1-1/8" steerer tube, 20x110mm axle, offset 56mm. Settings: low-speed compression, low-speed rebound, air preload
HEADSET	Onoff Mercurium 1.5 ZS for 1-1/8" steerer tube, 41x30.15x7x45°x45° ACB sealed bearings, geometry kit cups, external diameter 56mm
STEM	Onoff Krypton DH CNC Integrated FG, 25-30mm adjustable length, 31.8mm barbore, 6061 alloy, 2x6mm spacer
HANDLEBAR	Onoff Sulfur 1.0 double butted 6061 alloy, rise: 20mm, width: 800mm, 9° backsweep, 5° upsweep, 31.8mm barbore
GRIPS	Onoff Diamond, 1lock-on, 135mm
SEATPOST	SDG Micro I-Beam SP-751 Alloy, diameter 31.6mm, length 300mm, micro-adjustment
SADDLE	SDG I-Fly 2.0 I-Beam, high-density PU foam, Cordura sides
FRONT BRAKE	Sram Code R, oversized 4-piston caliper, Centerline 203mm IS 6 bolts one-piece rotor, steel-backed metal sintered pads
REAR BRAKE	Sram Code R, oversized 4-piston caliper, Centerline 203mm IS 6 bolts one-piece rotor, steel-backed metal sintered pads
BRAKE LEVER	Sram Code R, tool-free reach adjust
RIMS	e*thirteen LG1 Plus DH, IW29 29" Hookless, 6069 Welded Aluminum, 30mm internal width, tubeless ready, 32 spokes
SPOKES	e*thirteen custom Hive triple-buttet black alloy, alloy nipples, nipple washers
FRONT HUB	e*thirteen Boost 20x110mm, triple-sealed, fully machined aluminum, IS 6 bolts
REAR HUB	e*thirteen Superboost 12x157mm, triple-sealed, fully machined aluminum w/6-degree engagement, IS 6 bolts

FRONT TIRE	Michelin DH34 29x2.4, tubeless ready, Magi-X DH compound, double-reinforced DH shield casing, wire bead
REAR TIRE	Michelin DH34 29x2.4, tubeless ready, Magi-X DH compound, double-reinforced DH shield casing, wire bead
CRANKSET	Truativ Descendant DH, DUB axle, Direct mount chain ring, 165mm
RINGS	34T, steel, X-SYNC
BOTTOM BRACKET	Sram DUB BSA, sealed bearings, 83mm
PEDALS	---
CHAIN	Sram PC1110 11s, Powerlock
FRONT DERRAILLEUR	E.13 Vario Compact Upper Slider ,Alloy backplate ,DMB (Direct mount Bashguard) Lower Slider 34-36t, ISCG 05 adjustable upper slider
REAR DERRAILLEUR	Sram GX DH, 7s, medium cage, X-actuation 1:1
SHIFT LEVERS	Sram trigger GX DH 7s, X-actuation 1:1
CASSETTE	Sram PG 720 11-25T, 7s
DERAILLEUR HANGER	---
OTHERS	*Optional geometry kit: +-1° / +-2° headset cups
WEIGHT	---



DOWNHILL

SUMMUM R

Gloss British Racing Green / Black / Yellow

FRAME	Summum 29 6061 Alloy Stealth Evo, hydroformed tubing, Zero suspension system, 200mm travel, Forward Geometry, alloy upper link with shock eyelet bearings, SuperBoost 12x157mm rear axle, 83mm BSA bottom bracket, MAX. capacity dual raw Enduro bearings, HHG internal cable routing, ISCG 05. *Optional Geometry kit
SIZES	S / M / L / XL 29" and MX
REAR SHOCK	Fox DHX2 Performance Elite, 225x70mm. Settings: low-speed compression, low-speed rebound, spring preload. Trunnion top mount, 30x8mm bottom bushings
SHOCK SETTINGS	ECC010 compression, ECR012 rebound. Spring rate: S size 400 lbs, M size 450 lbs, L/XL size 500 lbs
FORK	Fox 40 29 Float FIT GRIP EVOL Performance, 203mm, air spring, 1-1/8" steerer tube, 20x110mm axle, offset 56mm. Settings: low-speed compression, low-speed rebound, air preload
HEADSET	Onoff Mercurium 1.5 Z5 for 1-1/8" steerer tube, 41x30.15x7x45°x45° ACB sealed bearings, geometry kit cups, external diameter 56mm
STEM	Onoff Krypton DH CNC Integrated FG, 25-30mm adjustable length, 31.8mm barbore, 6061 alloy, 2x6mm spacer
HANDLEBAR	Onoff Sulfur 1.0 double butted 6061 alloy, rise: 20mm, width: 800mm, 9° backsweep, 5° upsweep, 31.8mm barbore
GRIPS	Onoff Diamond, 1lock-on, 135mm
SEATPOST	SDG Micro I-Beam SP-751 Alloy, diameter 31.6mm, length 300mm, micro-adjustment
SADDLE	SDG I-Fly 2.0 I-Beam, high-density PU foam, Cordura sides
FRONT BRAKE	Sram Code R, oversized 4-piston caliper, Centerline 203mm IS 6 bolts one-piece rotor, steel-backed metal sintered pads
REAR BRAKE	Sram Code R, oversized 4-piston caliper, Centerline 203mm IS 6 bolts one-piece rotor, steel-backed metal sintered pads
BRAKE LEVER	Sram Code R, tool-free reach adjust
RIMS	e*thirteen LG1 Plus DH, IW29 29" Hookless, 6069 Welded Aluminum, 30mm internal width, tubeless ready, 32 spokes
SPOKES	e*thirteen custom Hive triple-buttet black alloy, alloy nipples, nipple washers
FRONT HUB	e*thirteen Boost 20x110mm, triple-sealed, fully machined aluminum, IS 6 bolts
REAR HUB	e*thirteen Superboost 12x157mm, triple-sealed, fully machined aluminum w/6-degree engagement, IS 6 bolts

FRONT TIRE	Michelin DH34 29x2.4, tubeless ready, Magi-X DH compound, double-reinforced DH shield casing, wire bead
REAR TIRE	Michelin DH34 29x2.4, tubeless ready, Magi-X DH compound, double-reinforced DH shield casing, wire bead
CRANKSET	Truativ Descendant DH, DUB axle, Direct mount chain ring, 165mm
RINGS	34T, steel, X-SYNC
BOTTOM BRACKET	Sram DUB BSA, sealed bearings, 83mm
PEDALS	---
CHAIN	Sram PC1110 11s, Powerlock
FRONT DERRAILLEUR	E.13 Vario Compact Upper Slider ,Alloy backplate ,DMB (Direct mount Bashguard) Lower Slider 34-36t, ISCG 05 adjustable upper slider
REAR DERRAILLEUR	Sram GX DH, 7s, medium cage, X-actuation 1:1
SHIFT LEVERS	Sram trigger GX DH 7s, X-actuation 1:1
CASSETTE	Sram PG 720 11-25T, 7s
DERAILLEUR HANGER	Mondraker M068
OTHERS	*Optional geometry kit: +-1° / +-2° headset cups
WEIGHT	---



DOWNHILL

SUMMUM

Gloss Dirty White / Deep Purple / Flame Red

FRAME	Summum 29 6061 Alloy Stealth Evo, hydroformed tubing, Zero suspension system, 200mm travel, Forward Geometry, alloy upper link with shock eyelet bearings, SuperBoost 12x157mm rear axle, 83mm BSA bottom bracket, MAX. capacity dual raw Enduro bearings, HHG internal cable routing, ISCG 05. *Optional Geometry kit
SIZES	S / M / L / XL 29" and MX
REAR SHOCK	Fox Van RC Performance, 225x70mm. Settings: low-speed compression, low-speed rebound, spring preload. Trunnion top mount, 30x8mm bottom bushings
SHOCK SETTINGS	Light compression, light rebound. Spring rate: S size 400 lbs, M size 400 lbs, L size 450 lbs, XL size 500 lbs
FORK	Rockshox Boxxer Select RC 29, 200mm, DebonAir, 1-1/8" steerer tube, Boost 20x110mm axle, offset 56mm. Settings: low-speed compression, rebound, air preload
HEADSET	Onoff Mercurium 1.5 ZS for 1-1/8" steerer tube, 41x30.15x7x45°x45° ACB sealed bearings, geometry kit cups, external diameter 56mm
STEM	Onoff Krypton DH CNC Integrated FG, 25-30mm adjustable length, 31.8mm barbore, 6061 alloy, 2x6mm spacer
HANDLEBAR	Onoff Sulfur 1.0 double butted 6061 alloy, rise: 20mm, width: 800mm, 9° backsweep, 5° upsweep, 31.8mm barbore
GRIPS	Onoff Diamond, 1lock-on, 135mm
SEATPOST	SDG Micro I-Beam SP-751 Alloy, diameter 31.6mm, length 300mm, micro-adjustment
SADDLE	SDG I-Fly 2.0 I-Beam, high-density PU foam, Cordura sides
FRONT BRAKE	Sram Code R, oversized 4-piston caliper, Centerline 200mm IS 6 bolts one-piece rotor, steel-backed metal sintered pads
REAR BRAKE	Sram Code R, oversized 4-piston caliper, Centerline 203mm IS 6 bolts one-piece rotor, steel-backed metal sintered pads
BRAKE LEVER	Sram Code R, tool-free reach adjust
RIMS	MDK-DP129, 27mm internal width, 32 holes
SPOKES	CN stainless steel
FRONT HUB	MDK DA4371B-M20, Boost 20x110mm, IS 6 bolts
REAR HUB	MDK DA4352B, 12x157mm, sealed bearings, IS 6 bolts

FRONT TIRE	Michelin DH34 29x2.4, tubeless ready, Magi-X DH compound, double-reinforced DH shield casing, wire bead
REAR TIRE	Michelin DH34 29x2.4, tubeless ready, Magi-X DH compound, double-reinforced DH shield casing, wire bead
CRANKSET	Race Face Ride, alloy, 165mm
RINGS	36T
BOTTOM BRACKET	Race Face Chester, alloy, 165mm
PEDALS	---
CHAIN	Sram PC-951, 9s
FRONT DERRAILLEUR	E.13 Vario Compact Upper Slider ,Alloy backplate ,DMB (Direct mount Bashguard) Lower Slider 34-36t, ISCG 05 adjustable upper slider
REAR DERRAILLEUR	Sram X7, 9s, short cage, X-actuation 1:1
SHIFT LEVERS	Sram trigger X5, 9s, X-actuation 1:1
CASSETTE	Sram PG-950, 11-26T, 9s
DERAILLEUR HANGER	Mondraker M068
OTHERS	*Optional geometry kit: +-1° / +-2° headset cups
WEIGHT	---



SUPER ENDURO

SUPERFOXY CARBON RR

Matte Carbon UD / Gloss British Racing Green / Yellow

FRAME	SuperFoxy 29 Stealth Air full Carbon, Zero Suspension System, 160mm travel, Forward Geometry, Carbon Monoblock upper link, SuperBoost 12x157mm rear axle, tapered head tube, 73mm BSA bottom bracket, dedicated 1x drivetrain design, HHG internal cable routing, Enduro MAX sealed bearings, shock mudguard, ISCG 05, custom frame protectors. *Geometry kit included
SIZES	S: 380mm / M: 420mm / L: 470mm / XL: 510mm
REAR SHOCK	Öhlins TTX 22M Coil 205X65mm. Settings: high speed compression lever with climb mode, low-speed compression, rebound, air preload. Trunnion top mount, 22.2x10mm bottom bushings
SHOCK SETTINGS	C20 compression, R35 rebound
FORK	Öhlins RXF 38 M.2 29, 170mm, TTX18 Twin Tube cartridge, tapered steerer tube, Boost 15x110mm axle, offset 44mm. Settings: high speed compression lever with climb mode, low-speed compression, rebound, air preload, ramp chamber
HEADSET	Onoff Titan tapered for 1-1/8" to 1-1/2" head tube, ACB sealed bearings, top 41.8x30.5x8x45°x45°, bottom 51.9x40x8x45°x45°
STEM	Onoff Krypton FG 30mm, CNC, 31.8mm barbare
HANDLEBAR	Onoff Krypton Carbon 1.0, rise: 25mm, width: 800mm, 9° backsweep, 5° upsweep, 31.8mm barbare
GRIPS	Onoff Diamond, 1lock-on, 135mm
SEATPOST	Fox Transfer Factory Kashima internal, diameter 31.6mm, S size: 363.5x125mm, M/L size: 418.3x150mm, XL size: 475.1x175mm
SADDLE	SDG BEL-AIR 3.0, EVA foam, alloy rails
FRONT BRAKE	Sram Code RSC, oversized 4-piston caliper, Centerline 200mm IS 6 bolts one-piece rotor, steel-backed metal sintered pads
REAR BRAKE	Sram Code RSC, oversized 4-piston caliper, Centerline 200mm IS 6 bolts one-piece rotor, steel-backed metal sintered pads
BRAKE LEVER	Sram Code RSC, SwingLink and lever pivot bearings, tools-free reach and contact point adjust
RIMS	e*thirteen LG1 Plus Enduro, IW30 Hookless, 6069 Welded Aluminum, 30mm internal width, tubeless ready, 28 spokes
SPOKES	e*thirteen custom Hive triple-buttet black alloy, alloy nipples, nipple washers
FRONT HUB	e*thirteen Boost 15x110mm, triple-sealed, fully machined aluminum, IS 6 bolts
REAR HUB	e*thirteen Superboost 12x157mm, triple-sealed, fully machined aluminum w/6-degree engagement, IS 6 bolts, XD freehub

FRONT TIRE	Maxxis Assegai 29x2.5WT, tubeless ready, 3C MAXX GRIP compound, DH casing, 60x2TPI, folding bead
REAR TIRE	Maxxis Dissector 29x2.4WT, tubeless ready, 3C MAXX GRIP compound, DH casing, 60x2TPI, folding bead
CRANKSET	Sram X01 Carbon Eagle, SuperBoost, DUB axle, Direct mount chain ring, S/M size: 170mm, L/XL size: 175mm
RINGS	32T, CNC-machined alloy, X-SYNC 2
BOTTOM BRACKET	Sram DUB BSA, sealed bearings, 73mm
PEDALS	---
CHAIN	Sram GX Eagle, 12s, Powerlock
FRONT DERRAILLEUR	---
REAR DERRAILLEUR	Sram X01 Eagle, Type 3 roller bearing clutch, cage lock, 1x12s, X-Actuation 1:1
SHIFT LEVERS	Sram Trigger X01 Eagle, 12s, X-Actuation 1:1
CASSETTE	Sram XG-1275, 10-52T, 12s
DERAILLEUR HANGER	Mondraker M071
OTHERS	*Geometry kit included: 0° headset cups and chainstay adaptor for 450mm CS length
WEIGHT	---



SUPER ENDURO

SUPERFOXY CARBON R

Gloss Dirty White / Deep Purple / Flame Red

FRAME	SuperFoxy 29 Stealth Air full Carbon, Zero Suspension System, 160mm travel, Forward Geometry, Carbon Monoblock upper link, SuperBoost 12x157mm rear axle, tapered head tube, 73mm BSA bottom bracket, dedicated 1x drivetrain design, HHG internal cable routing, Enduro MAX sealed bearings, shock mudguard, ISCG 05, custom frame protectors. *Optional Geometry kit
SIZES	S: 380mm / M: 420mm / L: 470mm / XL: 510mm
REAR SHOCK	Öhlins TTX Air 205X65mm. Settings: high speed compression lever with climb mode, low-speed compression, rebound, air preload. Trunnion top mount, 22.2x10mm bottom bushings
SHOCK SETTINGS	C20 compression, R35 rebound
FORK	Fox 38 29 Float FIT GRIP EVOL Performance, 170mm, tapered steerer tube, Boost 15x110mm axle, offset 44mm. Settings: 3 positions with micro adjust compression, low-speed rebound, air preload
HEADSET	Onoff Titan tapered for 1-1/8" to 1-1/2" head tube, ACB sealed bearings, top 41.8x30.5x8x45°x45°, bottom 51.9x40x8x45°x45°
STEM	Onoff Sulfur FG 30mm 0°, 6061 forged alloy, 31.8mm barbare
HANDLEBAR	Onoff Sulfur 1.0 double butted 6061 alloy, rise: 20mm, width: 800mm, 9° backsweep, 5° upsweep, 31.8mm barbare
GRIPS	Onoff Diamond, 1lock-on, 135mm
SEATPOST	Onoff Pija dropper internal, diameter 31.6mm, S size: 337x100mm, M size 387x125mm, L size: 425x150mm, XL size: 465x170mm
SADDLE	SDG BEL-AIR 3.0, LPU foam, steel rails
FRONT BRAKE	Sram Code R, oversized 4-piston caliper, Centerline 200mm CenterLock, steel-backed metal sintered pads
REAR BRAKE	Sram Code R, oversized 4-piston caliper, Centerline 200mm CenterLock, steel-backed metal sintered pads
BRAKE LEVER	Sram Code R, tool-free reach adjust
RIMS	DT Swiss E1900 Spline 29, 30mm internal width, sleeved aluminum, tubeless ready, 28 spokes
SPOKES	DT Champion, straightpull
FRONT HUB	DT 370, Boost 15x110mm, CenterLock
REAR HUB	DT 370, SuperBoost 12x157mm, 3 Pawl system, CenterLock, XD freehub

FRONT TIRE	Maxxis Assegai 29x2.5WT, tubeless ready, 3C MAXX GRIP compound, DH casing, 60x2TPI, folding bead
REAR TIRE	Maxxis Dissector 29x2.4WT, tubeless ready, 3C MAXX GRIP compound, DH casing, 60x2TPI, folding bead
CRANKSET	Truvativ Descendant 7K Eagle, SuperBoost, DUB axle, Direct mount chain ring, S/M size: 170mm, L/XL size: 175mm
RINGS	32T, CNC-machined alloy, X-SYNC 2
BOTTOM BRACKET	Sram DUB BSA, sealed bearings, 73mm
PEDALS	---
CHAIN	Sram NX Eagle, 12s, Powerlock
FRONT DERRAILLEUR	---
REAR DERRAILLEUR	Sram GX Eagle, Type 3 roller bearing clutch, cage lock, 1x12s, X-Actuation 1:1
SHIFT LEVERS	Sram Trigger GX Eagle, 12s, X-Actuation 1:1
CASSETTE	Sram XG-1275, 10-52T, 12s
DERAILLEUR HANGER	Mondraker M071
OTHERS	*Optional geometry kit: 0° headset cups and chainstay adaptor for 450mm CS length
WEIGHT	---



SUPER ENDURO

SUPERFOXY R

Gloss Frost Green / Black / Yellow

FRAME	SuperFoxy 29 6061 Alloy Stealth Evo, hydroformed tubing, Zero Suspension System, 160mm travel, Forward Geometry, one piece Monoblock upper link, SuperBoost 12x157mm rear axle, tapered head tube, 73mm BSA bottom bracket, dedicated 1x drivetrain design, telescopic seatpost internal routing, Max. capacity sealed bearings, ISCG 05
SIZES	S: 380mm / M: 420mm / L: 470mm / XL: 510mm
REAR SHOCK	Öhlins TTX Air 205X65mm. Settings: high speed compression lever with climb mode, low-speed compression, rebound, air preload. Trunnion top mount, 22.2x10mm bottom bushings
SHOCK SETTINGS	C20 compression, R35 rebound
FORK	Öhlins RXF 38 M.2 29, 170mm, TTX18 Twin Tube cartridge, tapered steerer tube, Boost 15x110mm axle, offset 44mm. Settings: high speed compression lever with climb mode, low-speed compression, rebound, air preload, ramp chamber
HEADSET	Onoff Saturn tapered for 1-1/8" to 1-1/2" head tube, ACB sealed bearings, top 41x30.2x7x45°x45°, bottom 51.9x40x8x45°x45°
STEM	Onoff Sulfur FG 30mm 0°, 6061 forged alloy, 31.8mm barbare
HANDLEBAR	Onoff Sulfur 1.0 double butted 6061 alloy, rise: 20mm, width: 800mm, 9° backsweep, 5° upsweep, 31.8mm barbare
GRIPS	Onoff Diamond, 1lock-on, 135mm
SEATPOST	Onoff Pija dropper internal, diameter 31.6mm, S size: 337x100mm, M size 387x125mm, L size: 425x150mm, XL size: 465x170mm
SADDLE	SDG BEL-AIR 3.0, LPU foam, steel rails
FRONT BRAKE	Sram Code R, oversized 4-piston caliper, Centerline 200mm IS 6 bolts one-piece rotor, steel-backed metal sintered pads
REAR BRAKE	Sram Code R, oversized 4-piston caliper, Centerline 200mm IS 6 bolts one-piece rotor, steel-backed metal sintered pads
BRAKE LEVER	Sram Code R, tool-free reach adjust
RIMS	Mavic Custom Deemax 29, 28mm internal width, Maxtal welded rim, tubeless ready, 28 spokes
SPOKES	Mavic J-bend duple butted
FRONT HUB	Mavic, Boost 15x110mm, IS 6 bolts
REAR HUB	Mavic, SuperBoost 12x157mm, ID360 Ratched system, IS 6 bolts

FRONT TIRE	Maxxis Assegai 29x2.5WT, tubeless ready, 3C MAXX GRIP compound, DH casing, 60x2TPI, folding bead
REAR TIRE	Maxxis Dissector 29x2.4WT, tubeless ready, 3C MAXX GRIP compound, DH casing, 60x2TPI, folding bead
CRANKSET	Truvativ Descendant 7K Eagle, SuperBoost, DUB axle, Direct mount chain ring, S/M size: 170mm, L/XL size: 175mm
RINGS	32T, CNC-machined alloy, X-SYNC 2
BOTTOM BRACKET	Sram DUB BSA, sealed bearings, 73mm
PEDALS	---
CHAIN	Sram SX Eagle, 12s, Powerlock
FRONT DERRAILLEUR	---
REAR DERRAILLEUR	Sram NX Eagle, Type 3 roller bearing clutch, cage lock, long cage, 1x12s, X-actuation 1:1
SHIFT LEVERS	Sram Trigger SX Eagle, 12s, X-Actuation 1:1
CASSETTE	Sram XG-1230, 11-50T, 12s
DERAILLEUR HANGER	Mondraker M068
OTHERS	---
WEIGHT	---



SUPER ENDURO

SUPERFOXY

Gloss Black / Cherry Red

FRAME	SuperFoxy 29 6061 Alloy Stealth Evo, hydroformed tubing, Zero Suspension System, 160mm travel, Forward Geometry, one piece Monoblock upper link, SuperBoost 12x157mm rear axle, tapered head tube, 73mm BSA bottom bracket, dedicated 1x drivetrain design, telescopic seatpost internal routing, Max. capacity sealed bearings, ISCG 05
SIZES	S: 380mm / M: 420mm / L: 470mm / XL: 510mm
REAR SHOCK	Fox Float X LV EVOL Performance, 205x65mm. Settings: compression 2 positions lever, low-speed rebound, air preload. Trunnion top mount, 22.2x10mm bottom bushings
SHOCK SETTINGS	Medium compression, medium rebound, air volume spacer 0.2
FORK	RockShox Zeb RC 29, 170mm, Charger, DebonAir, tapered steerer tube, Boost 15x110mm axle, 38mm aluminum stanchions, offset 44mm. Settings: low-speed compression to lock, rebound, air preload
HEADSET	Onoff Saturn tapered for 1-1/8" to 1-1/2" head tube, ACB sealed bearings, top 41x30.2x7x45°x45°, bottom 51.9x40x8x45°x45°
STEM	Onoff Sulfur FG 30mm 0°, 6061 forged alloy, 31.8mm barbare
HANDLEBAR	Onoff Sulfur 1.0 double butted 6061 alloy, rise: 20mm, width: 800mm, 9° backsweep, 5° upsweep, 31.8mm barbare
GRIPS	Onoff Twin, 1lock-on, 135mm
SEATPOST	Onoff Pija dropper internal, diameter 31.6mm, S size: 337x100mm, M size 387x125mm, L size: 425x150mm, XL size: 465x170mm
SADDLE	SDG BEL-AIR 3.0, LPU foam, steel rails
FRONT BRAKE	Sram G2 R, 4-piston caliper, Centerline 200mm IS 6 bolts one-piece rotor, steel-backed organic pads
REAR BRAKE	Sram G2 R, 4-piston caliper, Centerline 200mm IS 6 bolts one-piece rotor, steel-backed organic pads
BRAKE LEVER	Sram G2 R, tool-free reach adjust
RIMS	Mavic Custom Deemax 29, 28mm internal width, Maxtal welded rim, tubeless ready, 28 spokes
SPOKES	Mavic J-bend duple butted
FRONT HUB	Mavic, Boost 15x110mm, IS 6 bolts
REAR HUB	Mavic, SuperBoost 12x157mm, ID360 Ratched system, IS 6 bolts

FRONT TIRE	Maxxis Assegai 29x2.5WT, tubeless ready, 3C MAXX GRIP compound, DH casing, 60x2TPI, folding bead
REAR TIRE	Maxxis Dissector 29x2.4WT, tubeless ready, 3C MAXX GRIP compound, DH casing, 60x2TPI, folding bead
CRANKSET	Truvativ Descendant 7K Eagle, SuperBoost, DUB axle, Direct mount chain ring, S/M size: 170mm, L/XL size: 175mm
RINGS	32T, CNC-machined alloy, X-SYNC 2
BOTTOM BRACKET	Sram DUB BSA, sealed bearings, 73mm
PEDALS	---
CHAIN	Sram SX Eagle, 12s, Powerlock
FRONT DERRAILLEUR	---
REAR DERRAILLEUR	Sram SX Eagle, Type 3 roller bearing clutch, cage lock, long cage, 1x12s, X-actuation 1:1
SHIFT LEVERS	Sram Trigger SX Eagle, 12s, X-Actuation 1:1
CASSETTE	Sram PG-1210, 11-50T, 12s
DERAILLEUR HANGER	Mondraker M068
OTHERS	---
WEIGHT	---



XC RACE

F-PODIUM DC RR

Matte Carbon UD / Gloss Racing Silver

FRAME	F-Podium 29 Stealth Air Full Carbon, XCO Optimized Zero Suspension System, 115mm, XC Forward Geometry, Carbon Monoblock upper link, BSA bottom bracket, tapered head tube, HHG internal cable routing, dedicated 1X drivetrain design, Boost 12x148mm rear axle, shock mudguard, postmount rear brake mount
SIZES	S: 390mm / M: 420mm / L: 470mm / XL: 510mm
REAR SHOCK	Rockshox SID Luxe Ultimate RLR Debonair, 185x50mm. Settings: TwistLock 2 position remote compression (open/lock), low-speed rebound, air preload. Trunnion top mount, 22.2x10mm bottom bushings
SHOCK SETTINGS	Light compression, medium rebound, Lockout 430, 1 Token
FORK	Rockshox SID Ultimate RL 29, 120mm, Charger Race day, Debonair, tapered steerer tube, Boost 15x110mm axle, 35mm tapered aluminum stanchions, offset 44mm. Settings: TwistLock 2 position remote compression (open/lock), low-speed rebound, air preload
FORK REMOTE	RockShox TwistLoc Fork + Shock
HEADSET	Acros AZX-239 R1 Block Lock, Z544/28.6 top, Z556/40 bottom
STEM	Onoff Helium 7075 alloy CNC, 31.8mm barbare, rise: +/-5°, length: sizes S/M: 50mm, size L: 60mm, size XL: 70mm
HANDLEBAR	Onoff Helium Carbon 0.2, rise: 4.8mm, width: 760mm, 9° backsweep, 0° upsweep, 31.8mm barbare
GRIPS	Rock Shox Twistloc grips
SEATPOST	RockShox Reverb Stealth AXS, diameter 31.6mm S size: 340x100mm, M size 390x125mm, L/XL size: 440x150mm
SADDLE	Fizik Antares R7
FRONT BRAKE	Sram Level TLM, 2 piece caliper, Centerline 180mm IS 6 bolts one-piece rotor, steel-backed organic pad
REAR BRAKE	Sram Level TLM, 2 piece caliper, Centerline 160mm IS 6 bolts one-piece rotor, steel-backed organic pad
BRAKE LEVER	Sram Level TLM, Direct Link actuation, tooled reach adjust, lever pivot bushings
RIMS	Mavic Crossmax Carbon XL R 29, 30mm internal width, hookless, tubeless ready, 24 spokes
SPOKES	Mavic straightpull double butted, contactless lacing

FRONT HUB	Mavic, Boost 15x110mm, IS 6 bolts
REAR HUB	Mavic, Boost 12x148mm, ID360 Ratched system, IS 6 bolts, XD freehub
FRONT TIRE	Maxxis Rekon Race 29x2.4, EXO protection, tubeless ready, 120TPI, folding bead
REAR TIRE	Maxxis Rekon Race 29x2.4, EXO protection, tubeless ready, 120TPI, folding bead
CRANKSET	Sram XX1 Carbon Eagle, Boost, DUB axle, Direct mount chain ring, S size: 170mm, M/L/XL size: 175mm
RINGS	34T, CNC-machined alloy
BOTTOM BRACKET	Sram DUB BSA, sealed bearings, 73mm
PEDALS	---
CHAIN	Sram XX1 Eagle, 12s, Powerlock
FRONT DERRAILLEUR	---
REAR DERRAILLEUR	Sram XX1 Eagle AXS, Type 2.1 roller bearing clutch, cage lock, long carbon cage, 1x12s, X-actuation 1:1
SHIFT LEVERS	Sram Eagle AXS, 12s
CASSETTE	Sram XG-1299, 10-50T, 12s
DERAILLEUR HANGER	Sram UDH
OTHERS	---
WEIGHT	---



XC RACE

F-PODIUM DC R

Matte Carbon UD / Gloss Black / Racing Silver

FRAME	F-Podium 29 Stealth Air Full Carbon, XCO Optimized Zero Suspension System, 115mm, XC Forward Geometry, Carbon Monoblock upper link, BSA bottom bracket, tapered head tube, HHG internal cable routing, dedicated 1X drivetrain design, Boost 12x148mm rear axle, shock mudguard, postmount rear brake mount
SIZES	S: 390mm / M: 420mm / L: 470mm / XL: 510mm
REAR SHOCK	Rockshox SID Luxe Ultimate RLR Debonair, 185x50mm. Settings: One lock, low-speed rebound, air preload. Trunnion top mount, 22.2x10mm bottom bushings
SHOCK SETTINGS	Firm compression, light rebound, air volume spacer 0.2
FORK	Rockshox SID Ultimate RL 29, 120mm, Charger Race day, Debonair, tapered steerer tube, Boost 15x110mm axle, 35mm tapered aluminum stanchions, offset 44mm. Settings: One lock, Low-speed rebound, air preload
FORK REMOTE	RockShox OneLoc
HEADSET	Acros AZX-239 R1 Block Lock, ZS44/28.6 top, ZS56/40 bottom
STEM	MDK, 6061 T6 Alloy, 31.8mm barbore, rise: +/-5°, length: sizes S/M: 50mm, size L: 60mm, size XL: 70mm
HANDLEBAR	Onoff Sulfur 0.2, double butted 6061 alloy, rise: 4.8mm, width: 760mm, 9° backsweep, 0° upsweep, 31.8mm barbore
GRIPS	Onoff Diamond, 1lock-on, 135mm
SEATPOST	Onoff Pija dropper internal, diameter 31.6mm, S size: 337x100mm, M/L/XL size 387x125mm
SADDLE	Fizik Antares R7
FRONT BRAKE	Sram Level TL, 2 piece caliper, Centerline 180mm IS 6 bolts one-piece rotor, steel-backed organic pad
REAR BRAKE	Sram Level TL, 2 piece caliper, Centerline 160mm IS 6 bolts one-piece rotor, steel-backed organic pad
BRAKE LEVER	Sram Level TL, Direct Link actuation, tooled reach adjust, lever pivot bushings
RIMS	Mavic Crossmax Carbon XL R 29, 30mm internal width, hookless, tubeless ready, 24 spokes
SPOKES	Mavic straightpull double butted, contactless lacing

FRONT HUB	Mavic, Boost 15x110mm, IS 6 bolts
REAR HUB	Mavic, Boost 12x148mm, ID360 Ratched system, IS 6 bolts, XD freehub
FRONT TIRE	Maxxis Rekon Race 29x2.4, EXO protection, tubeless ready, 120TPI, folding bead
REAR TIRE	Maxxis Rekon Race 29x2.4, EXO protection, tubeless ready, 120TPI, folding bead
CRANKSET	Sram X1 Carbon Eagle, Boost, DUB axle, Direct mount chain ring, S size: 170mm, M/L/XL size: 175mm
RINGS	34T, CNC-machined alloy, X-SYNC 2
BOTTOM BRACKET	Sram DUB BSA, sealed bearings, 73mm
PEDALS	---
CHAIN	Sram GX Eagle, 12s, Powerlock
FRONT DERRAILLEUR	---
REAR DERRAILLEUR	Sram X01 Eagle, Type 3 roller bearing clutch, cage lock, 1x12s, X-Actuation 1:1
SHIFT LEVERS	Sram Trigger GX Eagle, 12s, X-Actuation 1:1
CASSETTE	Sram XG-1275, 10-50T, 12s
DERAILLEUR HANGER	Sram UDH
OTHERS	---
WEIGHT	---



XC RACE

F-PODIUM DC

Matte Carbon UD / Gloss Cherry Red

FRAME	F-Podium 29 Stealth Air Full Carbon, XCO Optimized Zero Suspension System, 115mm, XC Forward Geometry, Carbon Monoblock upper link, BSA bottom bracket, tapered head tube, HHG internal cable routing, dedicated 1X drivetrain design, Boost 12x148mm rear axle, shock mudguard, postmount rear brake mount
SIZES	S: 390mm / M: 420mm / L: 470mm / XL: 510mm
REAR SHOCK	Rockshox SID Select+ RLR Debonair, 185x50mm. Settings: OneLock 2 position remote compression (open/lock), low-speed rebound, air preload. Trunnion top mount, 22.2x10mm bottom bushings
SHOCK SETTINGS	Light compression, medium rebound, Lockout 430, 1 Token
FORK	Rockshox SID Select RL 29, 120mm, Charger, Debonair, tapered steerer tube, Boost 15x110mm axle, 35mm tapered aluminum stanchions, offset 44mm. Settings: OneLock 2 position remote compression (open/lock), low-speed rebound, air preload
FORK REMOTE	RockShox OneLoc
HEADSET	Acros AZX-239 R1 Block Lock, ZS44/28.6 top, ZS56/40 bottom
STEM	MDK, 6061 T6 Alloy, 31.8mm barbare, rise: +/-5°, length: sizes S/M: 50mm, size L: 60mm, size XL: 70mm
HANDLEBAR	Onoff Sulfur 0.2, double butted 6061 alloy, rise: 4.8mm, width: 760mm, 9° backsweep, 0° upsweep, 31.8mm barbare
GRIPS	Onoff Twin, 1lock-on, 135mm
SEATPOST	Onoff Pija dropper internal, diameter 31.6mm, S size: 337x100mm, M/L/XL size 387x125mm
SADDLE	Fizik Antares R7
FRONT BRAKE	Sram Level T, 2 piece caliper, Centerline 180mm IS 6 bolts one-piece rotor, steel-backed organic pad
REAR BRAKE	Sram Level T, 2 piece caliper, Centerline 160mm IS 6 bolts one-piece rotor, steel-backed organic pad
BRAKE LEVER	Sram Level T, Direct Link actuation, tooled reach adjust, lever pivot bushings
RIMS	Mavic Crossmax 29, 25mm internal width, welded rim, hookless, tubeless ready, 24 spokes
SPOKES	Mavic straightpull duple butted, contactless lacing

FRONT HUB	Mavic, Boost 15x110mm, IS 6 bolts
REAR HUB	Mavic, Boost 12x148mm, ID360 Ratched system, IS 6 bolts
FRONT TIRE	Maxxis Rekon Race 29x2.4, EXO protection, tubeless ready, 120TPI, folding bead
REAR TIRE	Maxxis Rekon Race 29x2.4, EXO protection, tubeless ready, 120TPI, folding bead
CRANKSET	Truvativ Stylo 6K Eagle, 12s, Boost, DUB axle, Direct Mount chain ring, S size: 170mm, M/L/XL size: 175mm
RINGS	34T, steel, X-Sync 2
BOTTOM BRACKET	Sram DUB BSA, sealed bearings, 73mm
PEDALS	---
CHAIN	Sram SX Eagle, 12s, Powerlock
FRONT DERRAILLEUR	---
REAR DERRAILLEUR	Sram GX Eagle, Type 3 roller bearing clutch, cage lock, 1x12s, X-Actuation 1:1
SHIFT LEVERS	Sram Trigger SX Eagle, 12s, X-Actuation 1:1
CASSETTE	Sram XG-1230, 11-50T, 12s
DERAILLEUR HANGER	Sram UDH
OTHERS	---
WEIGHT	---



XC RACE

F-PODIUM R

Matte Carbon UD / Gloss Marlin Blue

FRAME	F-Podium 29 Stealth Air Full Carbon, XCO Optimized Zero Suspension System, 100mm, XC Forward Geometry, Carbon Monoblock upper link, BSA bottom bracket, tapered head tube, HHG internal cable routing, dedicated 1X drivetrain design, Boost 12x148mm rear axle, shock mudguard, postmount rear brake mount
SIZES	S: 390mm / M: 420mm / L: 470mm / XL: 510mm
REAR SHOCK	Fox Float DPS SV EVOL Factory Kashima, 185x47,5mm. Settings: 2 position remote compression (open/lock), low-speed rebound, air preload. Trunnion top mount, 22.2x10mm bottom bushings
SHOCK SETTINGS	Firm compression, light rebound, air volume spacer 0.2
FORK	Fox 34 Step Cast Float FIT4 Evol Factory Kashima, 110mm, tapered steerer tube, 15x110mm Boost axle, offset 44mm. Settings: remote 2pos Push-unlock, compression micro-adjustment at low-speed, rebound, air preload
FORK REMOTE	Fox dual pull
HEADSET	Acros AZX-239 R1 Block Lock, ZS44/28.6 top, ZS56/40 bottom
STEM	MDK, 6061 T6 Alloy, 31.8mm bar bore, rise: +/-5°, length: sizes S/M: 50mm, size L: 60mm, size XL: 70mm
HANDLEBAR	Onoff Helium Carbon 0.2, rise: 4.8mm, width: 760mm, 9° backsweep, 0° upsweep, 31.8mm bar bore
GRIPS	Onoff Diamond, 1lock-on, 135mm
SEATPOST	Onoff Helium Carbon 0-R, diameter 31.6mm, length 400mm
SADDLE	Fizik Antares R7
FRONT BRAKE	Sram Level TL, 2 piece caliper, Centerline 180mm IS 6 bolts one-piece rotor, steel-backed organic pad
REAR BRAKE	Sram Level TL, 2 piece caliper, Centerline 160mm IS 6 bolts one-piece rotor, steel-backed organic pad
BRAKE LEVER	Sram Level TL, Direct Link actuation, tooled reach adjust, lever pivot bushings
RIMS	Mavic Crossmax Carbon XL R 29, 30mm internal width, hookless, tubeless ready, 24 spokes
SPOKES	Mavic straightpull double butted, contactless lacing
FRONT HUB	Mavic, Boost 15x110mm, IS 6 bolts
REAR HUB	Mavic, Boost 12x148mm, ID360 Ratched system, IS 6 bolts, XD freehub

FRONT TIRE	Maxxis Rekon Race 29x2.35, EXO protection, tubeless ready, 120TPI, folding bead
REAR TIRE	Maxxis Rekon Race 29x2.35, EXO protection, tubeless ready, 120TPI, folding bead
CRANKSET	Sram X1 Carbon Eagle, Boost, DUB axle, Direct mount chain ring, S size: 170mm, M/L/XL size: 175mm
RINGS	34T, CNC-machined alloy, X-SYNC 2
BOTTOM BRACKET	Sram DUB BSA, sealed bearings, 73mm
PEDALS	---
CHAIN	Sram GX Eagle, 12s, Powerlock
FRONT DERRAILLEUR	---
REAR DERRAILLEUR	Sram X01 Eagle, Type 3 roller bearing clutch, cage lock, 1x12s, X-Actuation 1:1
SHIFT LEVERS	Sram Trigger GX Eagle, 12s, X-Actuation 1:1
CASSETTE	Sram XG-1275, 10-50T, 12s
DERAILLEUR HANGER	Sram UDH
OTHERS	---
WEIGHT	---



XC RACE

F-PODIUM

Matte Carbon UD / Gloss Dirty White

FRAME	F-Podium 29 Stealth Air Full Carbon, XCO Optimized Zero Suspension System, 100mm, XC Forward Geometry, Carbon Monoblock upper link, BSA bottom bracket, tapered head tube, HHG internal cable routing, dedicated 1X drivetrain design, Boost 12x148mm rear axle, shock mudguard, postmount rear brake mount
SIZES	S: 390mm / M: 420mm / L: 470mm / XL: 510mm
REAR SHOCK	Fox Float DPS SV Performance Elite, 185x47,5mm. Settings: 2 position remote compression (open/lock), low-speed rebound, air preload. Trunnion top mount, 22.2x10mm bottom bushings
SHOCK SETTINGS	Firm compression, light rebound, air volume spacer 0.2
FORK	Fox 34 Step Cast Float Grip Evol Performance, 110mm, tapered steerer tube, 15x110mm Boost axle, offset 44mm. Settings: remote 2pos Push-unlock, rebound, air preload
FORK REMOTE	Fox dual pull
HEADSET	Acros AZX-239 R1 Block Lock, Z544/28.6 top, Z556/40 bottom
STEM	MDK, 6061 T6 Alloy, 31.8mm bar bore, rise: +/-5°, length: sizes S/M: 50mm, size L: 60mm, size XL: 70mm
HANDLEBAR	Onoff Sulfur 0.2, double butted 6061 alloy, rise: 4.8mm, width: 760mm, 9° backsweep, 0° upsweep, 31.8mm bar bore
GRIPS	Onoff Diamond, 1lock-on, 135mm
SEATPOST	Onoff Sulfur 0-R, 6061 T6 Alloy, 3D forged, diameter 31.6mm, length 400mm
SADDLE	Fizik Antares R7
FRONT BRAKE	Sram Level T, 2 piece caliper, Centerline 180mm IS 6 bolts one-piece rotor, steel-backed organic pad
REAR BRAKE	Sram Level T, 2 piece caliper, Centerline 160mm IS 6 bolts one-piece rotor, steel-backed organic pad
BRAKE LEVER	Sram Level T, Direct Link actuation, tooled reach adjust, lever pivot bushings
RIMS	Mavic Crossmax 29, 25mm internal width, welded rim, hookless, tubeless ready, 24 spokes
SPOKES	Mavic straightpull double butted, contactless lacing

FRONT HUB	Mavic, Boost 15x110mm, IS 6 bolts
REAR HUB	Mavic, Boost 12x148mm, ID360 Ratched system, IS 6 bolts
FRONT TIRE	Maxxis Rekon Race 29x2.35, EXO protection, tubeless ready, 120TPI, folding bead
REAR TIRE	Maxxis Rekon Race 29x2.35, EXO protection, tubeless ready, 120TPI, folding bead
CRANKSET	Truvativ Stylo 6K Eagle, 12s, Boost, DUB axle, Direct Mount chain ring, S size: 170mm, M/L/XL size: 175mm
RINGS	34T, steel, X-Sync 2
BOTTOM BRACKET	Sram DUB BSA, sealed bearings, 73mm
PEDALS	---
CHAIN	Sram SX Eagle, 12s, Powerlock
FRONT DERRAILLEUR	---
REAR DERRAILLEUR	Sram GX Eagle, Type 3 roller bearing clutch, cage lock, 1x12s, X-Actuation 1:1
SHIFT LEVERS	Sram Trigger SX Eagle, 12s, X-Actuation 1:1
CASSETTE	Sram PG-1230, 11-50T, 12s
DERAILLEUR HANGER	Sram UDH
OTHERS	---
WEIGHT	---



XC RACE

PODIUM RR SL

Translucent Silver Carbon / Gloss Racing Silver

FRAME	Podium 29 Stealth Air Carbon, XC Forward Geometry, BSA bottom bracket, tapered head tube, HHG internal cable routing, Boost 12x148mm rear axle, dedicated 1X drivetrain design, Flatmount brake compatible
SIZES	S: 390mm / M: 420mm / L: 470mm / XL: 510mm
REAR SHOCK	---
SHOCK SETTINGS	---
FORK	Rockshox SID SL Ultimate RL 29, 100mm, Charger Race day, Debonair, tapered steerer tube, Boost 15x110mm axle, 32mm aluminum stanchions, offset 44mm. Settings: OneLock 2 position remote compression (open/lock), low-speed rebound, air preload
FORK REMOTE	RockShox OneLoc
HEADSET	Onoff Titan tapered for 1-1/8" to 1-1/2" head tube, ACB sealed bearings, top 41.8x30.5x8x45°x45°, bottom 51.9x40x8x45°x45°
STEM	Onoff Helium 7075 alloy CNC, 31.8mm barbare, rise: +/-5°, length: sizes S/M: 60mm, size L: 70mm, size XL: 80mm
HANDLEBAR	Onoff Helium Carbon 0.2, rise: 4.8mm, width: 760mm, 9° backsweep, 0° upsweep, 31.8mm barbare
GRIPS	Lizard DSP 30.3
SEATPOST	Onoff Helium Carbon 0-R VFLEX, diameter 27.2mm, length 400mm
SADDLE	Fizik Antares R7
FRONT BRAKE	Sram Level Ultimate, 2 piece caliper, Centerline 160mm IS 6 bolts one-piece rotor, steel-backed organic pad, titanium hardware
REAR BRAKE	Sram Level Ultimate, 2 piece caliper, Centerline 160mm IS 6 bolts one-piece rotor, steel-backed organic pad, titanium hardware
BRAKE LEVER	Sram Level Ultimate, carbon lever, Direct Link actuation, tooled reach adjust, lever pivot bearings, titanium hardware
RIMS	Mavic Crossmax Carbon SL Ultimate 29, 25mm internal width, hookless, tubeless ready, 24 spokes
SPOKES	Mavic straightpull duple butted, contactless lacing

FRONT HUB	Mavic, Boost 15x110mm, IS 6 bolts
REAR HUB	Mavic, Boost 12x148mm, ID360 Ratched system, IS 6 bolts, XD freehub
FRONT TIRE	Maxxis Rekon Race 29x2.35, EXO protection, tubeless ready, 120TPI, folding bead
REAR TIRE	Maxxis Rekon Race 29x2.35, EXO protection, tubeless ready, 120TPI, folding bead
CRANKSET	Sram XX1 Eagle, Boost, DUB axle, Direct mount chain ring, S size: 170mm, M/L/XL size: 175mm
RINGS	34T, CNC-machined alloy, X-SYNC 2
BOTTOM BRACKET	Sram DUB BSA, sealed bearings, 73mm
PEDALS	---
CHAIN	Sram XX1 Eagle, 12s, Powerlock
FRONT DERRAILLEUR	---
REAR DERRAILLEUR	Sram XX1 Eagle AXS, Type 2.1 roller bearing clutch, cage lock, long carbon cage, 1x12s, X-actuation 1.1, Battery protection
SHIFT LEVERS	Sram Eagle AXS, 12s Rocker paddle
CASSETTE	Sram XG1299 10-50T, 12s
DERAILLEUR HANGER	Sram UDH
OTHERS	---
WEIGHT	---



XC RACE

PODIUM R

Translucent Blue Carbon / Gloss Marlin Blue

FRAME	Podium 29 Stealth Air Carbon, XC Forward Geometry, BSA bottom bracket, tapered head tube, HHG internal cable routing, Boost 12x148mm rear axle, dedicated 1X drivetrain design, Flatmount brake compatible
SIZES	S: 390mm / M: 420mm / L: 470mm / XL: 510mm
REAR SHOCK	---
SHOCK SETTINGS	---
FORK	Fox 32 Step Cast Float FIT4 EVOL Factory Kashima, 100mm, tapered steerer tube, 15x110mm Boost axle, remote lockout, offset 44mm. Settings: lockout, compression micro-adjustment at low-speed, rebound, air preload
FORK REMOTE	Fox single pull
HEADSET	Onoff Titan tapered for 1-1/8" to 1-1/2" head tube, ACB sealed bearings, top 41.8x30.5x8x45°x45°, bottom 51.9x40x8x45°x45°
STEM	MDK, 6061 T6 Alloy, 31.8mm barbore, rise: +/-5°, length: sizes S/M: 60mm, size L: 70mm, size XL: 80mm
HANDLEBAR	Onoff Helium Carbon 0.2, rise: 4.8mm, width: 760mm, 9° backsweep, 0° upsweep, 31.8mm barbore
GRIPS	Onoff Diamond, 1lock-on, 135mm
SEATPOST	Onoff Helium Carbon 0-R VFLEX, diameter 27.2mm, length 400mm
SADDLE	Fizik Antares R7
FRONT BRAKE	Sram Level TLM, 2 piece caliper, Centerline 160mm IS 6 bolts one-piece rotor, steel-backed organic pad
REAR BRAKE	Sram Level TLM, 2 piece caliper, Centerline 160mm IS 6 bolts one-piece rotor, steel-backed organic pad
BRAKE LEVER	Sram Level TLM, Direct Link actuation, tooled reach adjust, lever pivot bushings
RIMS	Mavic Crossmax Carbon SL R 29, 26mm internal width, hookless, tubeless ready, 24 spokes
SPOKES	Mavic straightpull double butted, contactless lacing

FRONT HUB	Mavic, Boost 15x110mm, IS 6 bolts
REAR HUB	Mavic, Boost 12x148mm, ID360 Ratched system, IS 6 bolts, XD freehub
FRONT TIRE	Maxxis Rekon Race 29x2.35, EXO protection, tubeless ready, 120TPI, folding bead
REAR TIRE	Maxxis Rekon Race 29x2.35, EXO protection, tubeless ready, 120TPI, folding bead
CRANKSET	Truvativ Stylo Carbon Eagle, 12s, Boost, DUB axle, Direct Mount chain ring, S size: 170mm, M/L/XL size: 175mm
RINGS	34T, steel, X-Sync 2
BOTTOM BRACKET	Sram DUB BSA, sealed bearings, 73mm
PEDALS	---
CHAIN	Sram SX Eagle, 12s, Powerlock
FRONT DERRAILLEUR	---
REAR DERRAILLEUR	Sram X01 Eagle, Type 3 roller bearing clutch, cage lock, 1x12s, X-Actuation 1:2
SHIFT LEVERS	Sram Trigger GX Eagle, 12s, X-Actuation 1:2
CASSETTE	Sram XG-1275, 10-50T, 12s
DERAILLEUR HANGER	Sram UDH
OTHERS	---
WEIGHT	---



XC RACE

PODIUM

Translucent Red Carbon / Gloss Cherry Red

FRAME	Podium 29 Stealth Air Carbon, XC Forward Geometry, BSA bottom bracket, tapered head tube, HHG internal cable routing, Boost 12x148mm rear axle, dedicated 1X drivetrain design, Flatmount brake compatible
SIZES	S: 390mm / M: 420mm / L: 470mm / XL: 510mm
REAR SHOCK	---
SHOCK SETTINGS	---
FORK	Rockshox SID SL Base RL 29, 100mm, Charger, Debonair, tapered steerer tube, Boost 15x110mm axle, 32mm aluminum stanchions, offset 44mm. Settings: OneLock 2 position remote compression (open/lock), low-speed rebound, air preload
FORK REMOTE	RockShox OneLoc
HEADSET	Onoff Titan tapered for 1-1/8" to 1-1/2" head tube, ACB sealed bearings, top 41.8x30.5x8x45°x45°, bottom 51.9x40x8x45°x45°
STEM	MDK, 6061 T6 Alloy, 31.8mm barbore, rise: +/-5°, length: sizes S/M: 60mm, size L: 70mm, size XL: 80mm
HANDLEBAR	Onoff Sulfur 0.2, double butted 6061 alloy, rise: 4.8mm, width: 760mm, 9° backsweep, 0° upsweep, 31.8mm barbore
GRIPS	Onoff Diamond, 1lock-on, 135mm
SEATPOST	Onoff Sulfur 0-R, 6061 T6 Alloy, 3D forged, diameter 27.2mm, length 400mm
SADDLE	Fizik Antares R7
FRONT BRAKE	Sram Level TL, 2 piece caliper, Centerline 160mm IS 6 bolts one-piece rotor, steel-backed organic pad
REAR BRAKE	Sram Level TL, 2 piece caliper, Centerline 160mm IS 6 bolts one-piece rotor, steel-backed organic pad
BRAKE LEVER	Sram Level TL, Direct Link actuation, tooled reach adjust, lever pivot bushings
RIMS	Mavic Crossmax 29, 25mm internal width, welded rim, hookless, tubeless ready, 24 spokes
SPOKES	Mavic straightpull double butted, contactless lacing

FRONT HUB	Mavic, Boost 15x110mm, IS 6 bolts
REAR HUB	Mavic, Boost 12x148mm, ID360 Ratched system, IS 6 bolts
FRONT TIRE	Maxxis Rekon Race 29x2.35, EXO protection, tubeless ready, 120TPI, folding bead
REAR TIRE	Maxxis Rekon Race 29x2.35, EXO protection, tubeless ready, 120TPI, folding bead
CRANKSET	Sram GX Eagle, Boost, DUB axle, Direct Mount chain ring, S size: 170mm, M/L/XL size: 175mm
RINGS	34T, CNC-machined alloy, X-SYNC 2
BOTTOM BRACKET	Sram DUB BSA, sealed bearings, 73mm
PEDALS	---
CHAIN	Sram NX Eagle, 12s, Powerlock
FRONT DERRAILLEUR	---
REAR DERRAILLEUR	Sram GX Eagle, Type 3 roller bearing clutch, cage lock, 1x12s, X-Actuation 1:1
SHIFT LEVERS	Sram Trigger GX Eagle, 12s, X-Actuation 1:1
CASSETTE	Sram XG-1275, 10-50T, 12s
DERAILLEUR HANGER	Sram UDH
OTHERS	---
WEIGHT	---



XC PRO

CHRONO CARBON RR

Matte Carbon UD / Gloss Black / Racing Silver

FRAME	Chrono 29 Stealth full Carbon, XC Forward Geometry, 73mm BSA bottom bracket, tapered head tube, HHG Internal Cable routing, Boost 12x148mm rear axle, Comfort Flat chainstays (Flatstays) design
SIZES	S: 395mm / M: 430mm / L: 470mm / XL: 520mm
REAR SHOCK	---
SHOCK SETTINGS	---
FORK	Rockshox SID SL Ultimate RL 29, 100mm, Charger Race day, Debonair, tapered steerer tube, Boost 15x110mm axle, 32mm aluminum stanchions, offset 44mm. Settings: OneLock 2 position remote compression (open/lock), low-speed rebound, air preload
FORK REMOTE	RockShox OneLoc
HEADSET	Onoff Titan tapered for 1-1/8" to 1-1/2" head tube, ACB sealed bearings, top 41.8x30.5x8x45°x45°, bottom 51.9x40x8x45°x45°
STEM	MDK, 6061 T6 Alloy, 31.8mm barbare, rise: +/-5°, length: size S: 60mm, size M: 70mm, size L: 80mm, size XL: 90mm
HANDLEBAR	Onoff Sulfur 0.2, double butted 6061 alloy, rise: 4.8mm, width: 760mm, 9° backsweep, 0° upsweep, 31.8mm barbare
GRIPS	Onoff Diamond, 1lock-on, 135mm
SEATPOST	Onoff Sulfur 0-R, 6061 T6 Alloy, 3D forged, diameter 27.2mm, length 400mm
SADDLE	Mondraker XC Series, steel rail
FRONT BRAKE	Sram Level T, 2 piece caliper, Centerline 160mm IS 6 bolts one-piece rotor, steel-backed organic pad
REAR BRAKE	Sram Level T, 2 piece caliper, Centerline 160mm IS 6 bolts one-piece rotor, steel-backed organic pad
BRAKE LEVER	Sram Level T, Direct Link actuation, tooled reach adjust, lever pivot bushings
RIMS	Mavic Crossmax SL S 29, 25mm internal width, Maxtal welded rim, hookless, tubeless, 24 spokes
SPOKES	Mavic straightpull double butted, contactless lacing

FRONT HUB	Mavic, Boost 15x110mm, IS 6 bolts
REAR HUB	Mavic, Boost 12x148mm, ID360 Ratched system, IS 6 bolts
FRONT TIRE	Maxxis Ikon 29x2.20, 3CMaxx Speed compound, tubeless ready, 120TPI, folding bead
REAR TIRE	Maxxis Ikon 29x2.20, 3CMaxx Speed compound, tubeless ready, 120TPI, folding bead
CRANKSET	Sram GX Eagle, Boost, DUB axle, Direct Mount chain ring, S size: 170mm, M/L/XL size: 175mm
RINGS	34T, CNC-machined alloy, X-SYNC 2
BOTTOM BRACKET	Sram DUB BSA, sealed bearings, 73mm
PEDALS	---
CHAIN	Sram SX Eagle, 12s, Powerlock
FRONT DERRAILLEUR	---
REAR DERRAILLEUR	Sram GX Eagle, Type 3 roller bearing clutch, cage lock, 1x12s, X-Actuation 1:1
SHIFT LEVERS	Sram Trigger NX Eagle, 12s, X-Actuation 1:1
CASSETTE	Sram PG-1230, 11-50T, 12s
DERAILLEUR HANGER	Mondraker M068
OTHERS	---
WEIGHT	---



XC PRO

CHRONO CARBON R

Gloss Cherry Red / Matte Carbon UD

FRAME	Chrono 29 Stealth full Carbon, XC Forward Geometry, 73mm BSA bottom bracket, tapered head tube, HHG Internal Cable routing, Boost 12x148mm rear axle, Comfort Flat chainstays (Flatstays) design
SIZES	S: 395mm / M: 430mm / L: 470mm / XL: 520mm
REAR SHOCK	---
SHOCK SETTINGS	---
FORK	Rockshox SID SL Base RL 29, 100mm, Charger, Debonair, tapered steerer tube, Boost 15x110mm axle, 32mm aluminum stanchions, offset 44mm. Settings: OneLock 2 position remote compression (open/lock), low-speed rebound, air preload
FORK REMOTE	RockShox OneLoc
HEADSET	Onoff Titan tapered for 1-1/8" to 1-1/2" head tube, ACB sealed bearings, top 41.8x30.5x8x45°x45°, bottom 51.9x40x8x45°x45°
STEM	MDK, 6061 T6 Alloy, 31.8mm barbare, rise: +/-5°, length: size S: 60mm, size M: 70mm, size L: 80mm, size XL: 90mm
HANDLEBAR	Onoff Sulfur 0.2, double butted 6061 alloy, rise: 4.8mm, width: 760mm, 9° backsweep, 0° upsweep, 31.8mm barbare
GRIPS	Onoff Diamond, 1lock-on, 135mm
SEATPOST	Onoff Sulfur 0-R, 6061 T6 Alloy, 3D forged, diameter 27.2mm, length 400mm
SADDLE	Mondraker XC Series, steel rail
FRONT BRAKE	Sram Level T, 2 piece caliper, Centerline 160mm IS 6 bolts one-piece rotor, steel-backed organic pad
REAR BRAKE	Sram Level T, 2 piece caliper, Centerline 160mm IS 6 bolts one-piece rotor, steel-backed organic pad
BRAKE LEVER	Sram Level, tooled reach adjust, lever pivot bushings
RIMS	Mavic Crossmax 29, 25mm internal width, welded rim, hookless, tubeless ready, 24 spokes
SPOKES	Mavic straightpull double butted, contactless lacing

FRONT HUB	Mavic, Boost 15x110mm, IS 6 bolts
REAR HUB	Mavic, Boost 12x148mm, ID360 Ratched system, IS 6 bolts
FRONT TIRE	Maxxis Ikon 29x2.20, 3CMaxx Speed compound, tubeless ready, 120TPI, folding bead
REAR TIRE	Maxxis Ikon 29x2.20, 3CMaxx Speed compound, tubeless ready, 120TPI, folding bead
CRANKSET	Truvativ Stylo 6K Eagle, 12s, Boost, DUB axle, Direct Mount chain ring, S size: 170mm, M/L/XL size: 175mm
RINGS	34T, steel, X-Sync 2
BOTTOM BRACKET	Sram DUB BSA, sealed bearings, 73mm
PEDALS	---
CHAIN	Sram SX Eagle, 12s, Powerlock
FRONT DERRAILLEUR	---
REAR DERRAILLEUR	Sram GX Eagle, Type 3 roller bearing clutch, cage lock, 1x12s, X-Actuation 1:1
SHIFT LEVERS	Sram Trigger NX Eagle, 12s, X-Actuation 1:1
CASSETTE	Sram XG-1230, 11-50T, 12s
DERAILLEUR HANGER	Mondraker M068
OTHERS	---
WEIGHT	---



XC PRO

CHRONO CARBON

Gloss Dirty White / Matte Carbon UD

FRAME	Chrono 29 Stealth full Carbon, XC Forward Geometry, 73mm BSA bottom bracket, tapered head tube, HHG Internal Cable routing, Boost 12x148mm rear axle, Comfort Flat chainstays (Flatstays) design
SIZES	S: 395mm / M: 430mm / L: 470mm / XL: 520mm
REAR SHOCK	---
SHOCK SETTINGS	---
FORK	RockShox Judy Gold RL 29, 100mm, Motion control, Solo Air, tapered steerer tube, Boost 15x110mm axle, 30mm aluminum stanchions, offset 51mm. Settings: Onelock 2 pos remote compression (open/lock), rebound, air preload
FORK REMOTE	RockShox OneLoc
HEADSET	Onoff Titan tapered for 1-1/8" to 1-1/2" head tube, ACB sealed bearings, top 41.8x30.5x8x45°x45°, bottom 51.9x40x8x45°x45°
STEM	MDK, 6061 T6 Alloy, 31.8mm barbare, rise: +/-5°, length: size S: 60mm, size M: 70mm, size L: 80mm, size XL: 90mm
HANDLEBAR	Onoff Sulfur 0.2, double butted 6061 alloy, rise: 4.8mm, width: 760mm, 9° backsweep, 0° upsweep, 31.8mm barbare
GRIPS	Onoff Diamond, 1lock-on, 135mm
SEATPOST	Onoff Sulfur 0-R, 6061 T6 Alloy, 3D forged, diameter 27.2mm, length 400mm
SADDLE	Mondraker XC Series, steel rail
FRONT BRAKE	Sram Level T, 2 piece caliper, Centerline 160mm IS 6 bolts one-piece rotor, steel-backed organic pad
REAR BRAKE	Sram Level T, 2 piece caliper, Centerline 160mm IS 6 bolts one-piece rotor, steel-backed organic pad
BRAKE LEVER	Sram Level, tooled reach adjust, lever pivot bushings
RIMS	MDK-XP1 29 TLR, 25mm internal width, tubeless ready, 32 spokes
SPOKES	CN round stainless steel

FRONT HUB	Formula DC711, Boost 15x110mm, sealed bearings, IS 6 bolts
REAR HUB	Formula MST148S-45B, Boost 12x148mm, sealed bearings, IS 6 bolts
FRONT TIRE	Maxxis Ikon 29x2.20, 3CMaxx Speed compound, tubeless ready, 120TPI, folding bead
REAR TIRE	Maxxis Ikon 29x2.20, 3CMaxx Speed compound, tubeless ready, 120TPI, folding bead
CRANKSET	Sram SX Eagle, Boost, DUB axle, Direct Mount chain ring, S size: 170mm, M/L/XL size: 175mm
RINGS	34T, steel, X-Sync 2
BOTTOM BRACKET	Sram DUB BSA, sealed bearings, 73mm
PEDALS	---
CHAIN	Sram SX Eagle, 12s, Powerlock
FRONT DERRAILLEUR	---
REAR DERRAILLEUR	Sram NX Eagle, Type 3 roller bearing clutch, cage lock, long cage, 1x12s, X-actuation 1:1
SHIFT LEVERS	Sram Trigger SX Eagle, 12s, X-Actuation 1:1
CASSETTE	Sram XG-1230, 11-50T, 12s
DERAILLEUR HANGER	Mondraker M068
OTHERS	---
WEIGHT	---



XC PRO

CHRONO R

Color 1: Gloss Cherry Red / Black - Color 2: Gloss British Racing Green / Yellow

FRAME	Chrono 29 6061 Xtralite Alloy butted, XC Forward Geometry, 73mm BSA bottom bracket, tapered head tube, HHG Internal Cable Routing, Boost 12x148mm rear axle
SIZES	S: 395mm / M: 430mm / L: 470mm / XL: 520mm
REAR SHOCK	---
SHOCK SETTINGS	---
FORK	Rockshox SID SL Base RL 29, 100mm, Charger, Debonair, tapered steerer tube, Boost 15x110mm axle, 32mm aluminum stanchions, offset 44mm. Settings: OneLock 2 position remote compression (open/lock), low-speed rebound, air preload
FORK REMOTE	RockShox OneLoc
HEADSET	Onoff Saturn tapered for 1-1/8" to 1-1/2" head tube, ACB sealed bearings, top 41x30.2x7x45°x45°, bottom 51.9x40x8x45°x45°
STEM	Onoff Sulfur, 6061 T6 Alloy, 31.8mm bar bore, rise: +/-7°, length: sizes S/M: 60mm, size L: 80mm, size XL: 90mm
HANDLEBAR	Onoff Sulfur 0.2, double butted 6061 alloy, rise: 4.8mm, width: 740mm, 9° backsweep, 0° upsweep, 31.8mm bar bore
GRIPS	Onoff Diamond, 1lock-on, 135mm
SEATPOST	Onoff Sulfur 0-R, 6061 T6 Alloy, 3D forged, diameter 27.2mm, length 400mm
SADDLE	Mondraker XC Series, steel rail
FRONT BRAKE	Sram Level, 2 piece caliper, Centerline 160mm IS 6 bolts one-piece rotor, steel-backed organic pad
REAR BRAKE	Sram Level, 2 piece caliper, Centerline 160mm IS 6 bolts one-piece rotor, steel-backed organic pad
BRAKE LEVER	Sram Level, tooled reach adjust, lever pivot bushings
RIMS	MDK-XP1 29 TLR, 25mm internal width, tubeless ready, 32 spokes
SPOKES	CN round stainless steel
FRONT HUB	Formula DC711, Boost 15x110mm, sealed bearings, IS 6 bolts

REAR HUB	Formula MST148S-4SB, Boost 12x148mm, sealed bearings, IS 6 bolts
FRONT TIRE	Maxxis Ikon 29x2.20, 60TPI, wire bead
REAR TIRE	Maxxis Ikon 29x2.20, 60TPI, wire bead
CRANKSET	Truvativ Stylo 6K Eagle, 12s, Boost, DUB axle, Direct Mount chain ring, S size: 170mm, M/L/XL size: 175mm
RINGS	34T, steel, X-Sync 2
BOTTOM BRACKET	Sram DUB BSA, sealed bearings, 73mm
PEDALS	---
CHAIN	Sram SX Eagle, 12s, Powerlock
FRONT DERRAILLEUR	---
REAR DERRAILLEUR	Sram GX Eagle, Type 3 roller bearing clutch, cage lock, 1x12s, X-Actuation 1:1
SHIFT LEVERS	Sram Trigger SX Eagle, 12s, X-Actuation 1:1
CASSETTE	Sram PG-1210, 11-50T, 12s
DERAILLEUR HANGER	Mondraker M068
OTHERS	---
WEIGHT	---



XC PRO

CHRONO

Color 1: Matte Black / Racing Silver - Color 2: Gloss Dirty White / Black

FRAME	Chrono 29 6061 Xtralite Alloy butted, XC Forward Geometry, 73mm BSA bottom bracket, tapered head tube, HHG Internal Cable Routing, Boost 12x148mm rear axle
SIZES	S: 395mm / M: 430mm / L: 470mm / XL: 520mm
REAR SHOCK	---
SHOCK SETTINGS	---
FORK	RockShox Judy Silver TK 29, 100mm, TurnKey, Solo Air, tapered steerer tube, 9x100mm axle, 30mm steel stanchions, 46mm offset. Settings: Poplock 2 pos remote compression (open/lock), rebound, air preload
FORK REMOTE	RockShox PopLoc
HEADSET	Onoff Saturn tapered for 1-1/8" to 1-1/2" head tube, ACB sealed bearings, top 41x30.2x7x45°x45°, bottom 51.9x40x8x45°x45°
STEM	Onoff Sulfur, 6061 T6 Alloy, 31.8mm bar bore, rise: +/-7°, length: sizes S/M: 60mm, size L: 80mm, size XL: 90mm
HANDLEBAR	Onoff Sulfur 0.2, double butted 6061 alloy, rise: 4.8mm, width: 740mm, 9° backsweep, 0° upsweep, 31.8mm bar bore
GRIPS	Onoff Diamond, 1lock-on, 135mm
SEATPOST	Onoff Sulfur 0-R, 6061 T6 Alloy, 3D forged, diameter 27.2mm, length 400mm
SADDLE	Mondraker XC Series, steel rail
FRONT BRAKE	Sram Level, 2 piece caliper, Centerline 160mm IS 6 bolts one-piece rotor, steel-backed organic pad
REAR BRAKE	Sram Level, 2 piece caliper, Centerline 160mm IS 6 bolts one-piece rotor, steel-backed organic pad
BRAKE LEVER	Sram Level, tooled reach adjust, lever pivot bushings
RIMS	MDK-XP1 29 TLR, 25mm internal width, tubeless ready, 32 spokes
SPOKES	CN round stainless steel
FRONT HUB	Formula DC20LW, 9x100mm, cup & cone ball bearings, IS 6 bolts

REAR HUB	Formula MST148S-4SB, Boost 12x148mm, sealed bearings, IS 6 bolts, MS freehub
FRONT TIRE	Maxxis Ikon 29x2.20, 60TPI, wire bead
REAR TIRE	Maxxis Ikon 29x2.20, 60TPI, wire bead
CRANKSET	Sram SX Eagle, Boost, DUB axle, Direct Mount chain ring, S size: 170mm, M/L/XL size: 175mm
RINGS	34T, steel, X-Sync 2
BOTTOM BRACKET	Sram DUB BSA, sealed bearings, 73mm
PEDALS	---
CHAIN	Sram SX Eagle, 12s, Powerlock
FRONT DERRAILLEUR	---
REAR DERRAILLEUR	Sram SX Eagle, Type 3 roller bearing clutch, cage lock, long cage, 1x12s, X-actuation 1:1
SHIFT LEVERS	Sram Trigger SX Eagle, 12s, X-Actuation 1:1
CASSETTE	Sram PG-1210, 11-50T, 12s
DERAILLEUR HANGER	Mondraker M068
OTHERS	---
WEIGHT	---



e-MTB ENDURO

DUSK RR

Gloss Dirty White / Deep Purple / Flame Red

FRAME	Dusk 6061 Alloy Stealth Evo, e-Bike Optimized Zero Suspension System, 150mm travel, Forward Geometry, integrated internal non-removable battery, Boost 12x148mm rear axle, tapered head tube, one-piece Monoblock upper link, HHG internal cable routing, MAX capacity sealed bearings, oversize 17mm axles, integrated dropout speed sensor. *Optional external battery
SIZES	S: 380mm / M: 420mm / L: 450mm / XL: 490mm
REAR SHOCK	Fox Float DPS LV EVOL Performance, 205x65mm. Settings: Compression 3 positions lever, low-speed rebound, air preload. Trunnion top mount, 25x10mm bottom bushings
SHOCK SETTINGS	Medium compression, Medium rebound, 0.4 volume spacer
FORK	Fox 36 29 Float FIT4 EVOL Factory Kashima, 160mm, e-bike optimized, tapered steerer tube, Boost 15x110mm axle, 44mm offset, 68mm OD crown. Settings: 3 positions with micro adjust compression, low-speed rebound, air preload
HEADSET	Onoff Saturn tapered for 1-1/8" to 1-1/2" head tube, ACB sealed bearings, top 41x30.2x7x45°x45°, bottom 51.9x40x8x45°x45°
STEM	Onoff Sulfur FG 30mm 0°, 6061 forged alloy, 31.8mm barbare
HANDLEBAR	Onoff Sulfur 1.0 double butted 6061 alloy, rise: 20mm, width: 780mm, 9° backsweep, 5° upsweep, 31.8mm barbare
GRIPS	Onoff Diamond, 1lock-on, 135mm
SEATPOST	Fox Transfer Factory Kashima internal, diameter 31.6mm, S size: 363.5x125mm, M/L size: 418.3x150mm, XL size: 475.1x170mm
SADDLE	Fizik Terra Aidon X5 145mm
FRONT BRAKE	Sram Code R, oversized 4-piston caliper, Centerline 200mm IS 6 bolts one-piece rotor, steel-backed metal sintered pads
REAR BRAKE	Sram Code R, oversized 4-piston caliper, Centerline 200mm IS 6 bolts one-piece rotor, steel-backed metal sintered pads
BRAKE LEVER	Sram Code R, tool-free reach adjust
RIMS	DT Swiss H1900 Spline 29, 30mm internal width, sleeved aluminum, tubeless ready, 28 spokes
SPOKES	DT Hybrid SP, straightpull
FRONT HUB	DT 370, Boost 15x110mm, IS 6 bolts
REAR HUB	DT 370, Boost 12x148mm, Ratchet LN system, IS 6 bolts

FRONT TIRE	Maxxis Minion DHF 29x2.6, tubeless ready, 3C MAXX TERRA, EXO+ Protection, 120TPI, folding bead
REAR TIRE	Maxxis Minion DHR II 29x2.6, tubeless ready, 3C MAXX TERRA, EXO+ Protection, 120TPI, folding bead
CRANKSET	FSA, 165mm
RINGS	Sram X-Sync 2 Eagle 34T, steel, narrow-wide, 104 BCD
PEDALS	---
CHAIN	Sram SX Eagle, 12s, Powerlock
FRONT DERRAILLEUR	---
REAR DERRAILLEUR	Sram GX Eagle, Type 3 roller bearing clutch, cage lock, 1x12s, X-Actuation 1:1
SHIFT LEVERS	Sram Trigger GX Eagle, 12s, X-Actuation 1:1, single click
CASSETTE	Sram PG-1230, 11-50T, 12s
MOTOR	Shimano STEPS EP800
BATTERY	Simplo internal 630Wh
DISPLAY	Shimano STEPS E8000
DERRAILLEUR HANGER	Mondraker M068
OTHERS	*Optional external battery: Simplo 360Wh
WEIGHT	---



e-MTB ENDURO

DUSK R

Gloss Cherry Red / Black

FRAME	Dusk 6061 Alloy Stealth Evo, e-Bike Optimized Zero Suspension System, 150mm travel, Forward Geometry, integrated internal non-removable battery, Boost 12x148mm rear axle, tapered head tube, one-piece Monoblock upper link, HHG internal cable routing, MAX capacity sealed bearings, oversize 17mm axles, integrated dropout speed sensor. *Optional external battery
SIZES	S: 380mm / M: 420mm / L: 450mm / XL: 490mm
REAR SHOCK	Fox Float DPS LV EVOL Performance, 205x65mm. Settings: Compression 3 positions lever, low-speed rebound, air preload. Trunnion top mount, 25x10mm bottom bushings
SHOCK SETTINGS	Medium compression, Medium rebound, 0.4 volume spacer
FORK	Fox 36 29 Float FIT GRIP EVOL Rhythm, 160mm, tapered steerer tube, Boost 15x110mm axle, offset 44mm. Settings: sweep adjust compression, low-speed rebound, air preload
HEADSET	Onoff Saturn tapered for 1-1/8" to 1-1/2" head tube, ACB sealed bearings, top 41x30.2x7x45°x45°, bottom 51.9x40x8x45°x45°
STEM	Onoff Sulfur FG 30mm 0°, 6061 forged alloy, 31.8mm barbare
HANDLEBAR	Onoff Sulfur 1.0 double butted 6061 alloy, rise: 20mm, width: 780mm, 9° backsweep, 5° upsweep, 31.8mm barbare
GRIPS	Onoff Diamond, 1lock-on, 135mm
SEATPOST	Onoff Pija dropper internal, diameter 31.6mm, S size: 387x125mm, M size: 425x150mm, L/XL size: 465x170mm
SADDLE	Fizik Terra Aidon X5 145mm
FRONT BRAKE	Sram G2 R, 4-piston caliper, Centerline 200mm IS 6 bolts one-piece rotor, steel-backed organic pads
REAR BRAKE	Sram G2 R, 4-piston caliper, Centerline 200mm IS 6 bolts one-piece rotor, steel-backed organic pads
BRAKE LEVER	Sram G2 R, tool-free reach adjust
RIMS	MDK-HP1 29, 30mm internal width, tubeless ready, 32 spokes
SPOKES	CN round stainless steel
FRONT HUB	Formula DC711, Boost 15x110mm, sealed bearings, IS 6 bolts
REAR HUB	Formula EHL148 Boost 12x148mm, sealed bearings, IS 6 bolts

FRONT TIRE	Maxxis Minion DHF 29x2.6, tubeless ready, 3C MAXX TERRA, EXO+ Protection, 120TPI, folding bead
REAR TIRE	Maxxis Minion DHR II 29x2.6, tubeless ready, 3C MAXX TERRA, EXO+ Protection, 120TPI, folding bead
CRANKSET	FSA, 165mm
RINGS	Sram X-Sync 2 Eagle 34T, steel, narrow-wide, 104 BCD
PEDALS	---
CHAIN	Sram SX Eagle, 12s, Powerlock
FRONT DERRAILLEUR	---
REAR DERRAILLEUR	Sram NX Eagle, Type 3 roller bearing clutch, cage lock, long cage, 1x12s, X-actuation 1:1
SHIFT LEVERS	Sram Trigger NX Eagle, 12s, X-Actuation 1:1, single click
CASSETTE	Sram PG-1210, 11-50T, 12s
MOTOR	Shimano STEPS EP800
BATTERY	Simplo internal 630Wh
DISPLAY	Shimano STEPS E8000
DERAILLEUR HANGER	Mondraker M068
OTHERS	*Optional external battery: Simplo 360Wh
WEIGHT	---



e-MTB ENDURO

DUSK

Gloss Black / Dirty White

FRAME	Dusk 6061 Alloy Stealth Evo, e-Bike Optimized Zero Suspension System, 150mm travel, Forward Geometry, integrated internal non-removable battery, Boost 12x148mm rear axle, tapered head tube, one-piece Monoblock upper link, HHG internal cable routing, MAX capacity sealed bearings, oversize 17mm axles, integrated dropout speed sensor. *Optional external battery
SIZES	S: 380mm / M: 420mm / L: 450mm / XL: 490mm
REAR SHOCK	RockShox Deluxe Select R Debonair, 205x65mm. Settings: Low-speed rebound, air preload. Trunnion top mount, 25x10mm bottom bushings
SHOCK SETTINGS	---
FORK	RockShox 35 Silver TK 29, 160mm, TurnKey, Solo Air, tapered steerer tube, Boost 15x110mm axle, 35mm steel stanchions, 44mm offset. Settings: compression adjustment at low-speed to lock, rebound, air preload
HEADSET	Onoff Saturn tapered for 1-1/8" to 1-1/2" head tube, ACB sealed bearings, top 41x30.2x7x45°x45°, bottom 51.9x40x8x45°x45°
STEM	Onoff Sulfur FG 30mm 0°, 6061 forged alloy, 31.8mm barbare
HANDLEBAR	Onoff Sulfur 1.0 double butted 6061 alloy, rise: 20mm, width: 780mm, 9° backsweep, 5° upsweep, 31.8mm barbare
GRIPS	Onoff Diamond, 1lock-on, 135mm
SEATPOST	Onoff Pija dropper internal, diameter 31.6mm, S size: 387x125mm, M size: 425x150mm, L/XL size: 465x170mm
SADDLE	Fizik Terra Aidon X5 145mm
FRONT BRAKE	Sram G2 R, 4-piston caliper, Centerline 200mm IS 6 bolts one-piece rotor, steel-backed organic pads
REAR BRAKE	Sram G2 R, 4-piston caliper, Centerline 200mm IS 6 bolts one-piece rotor, steel-backed organic pads
BRAKE LEVER	Sram G2 R, tool-free reach adjust
RIMS	MDK-HP1 29, 30mm internal width, tubeless ready, 32 spokes
SPOKES	CN round stainless steel
FRONT HUB	Formula DC711, Boost 15x110mm, sealed bearings, IS 6 bolts
REAR HUB	Formula EHL148 Boost 12x148mm, sealed bearings, IS 6 bolts

FRONT TIRE	Maxxis Rekon 29x2.6, tubeless ready, dual compound, EXO protection, 60TPI, folding bead
REAR TIRE	Maxxis Rekon 29x2.6, tubeless ready, dual compound, EXO protection, 60TPI, folding bead
CRANKSET	FSA, 165mm
RINGS	Sram X-Sync 2 Eagle 34T, steel, narrow-wide, 104 BCD
PEDALS	---
CHAIN	Sram SX Eagle, 12s, Powerlock
FRONT DERRAILLEUR	---
REAR DERRAILLEUR	Sram SX Eagle, Type 3 roller bearing clutch, cage lock, long cage, 1x12s, X-actuation 1:1
SHIFT LEVERS	Sram Trigger SX Eagle, 12s, X-Actuation 1:1, single click
CASSETTE	Sram PG-1210, 11-50T, 12s
MOTOR	Shimano STEPS EP800
BATTERY	Simplo internal 630Wh
DISPLAY	Shimano STEPS E8000
DERRAILLEUR HANGER	Mondraker M068
OTHERS	*Optional external battery: Simplo 360Wh
WEIGHT	---



e-MTB ENDURO

CHASER

Color 1: Gloss Graphite / Black - Color 2: Gloss Cherry Red / Black

FRAME	Chaser 6061 Alloy Stealth Evo, e-Bike Optimized Zero Suspension System, 150mm travel, Forward Geometry, internal removable battery, Boost 12x148mm rear axle, tapered head tube, one-piece Monoblock upper link, HHG internal cable routing, MAX capacity sealed bearings, oversize 17mm axles, integrated dropout speed sensor, exclusive plastic motor covers, shock mudguard
SIZES	S: 380mm / M: 420mm / L: 450mm / XL: 490mm
REAR SHOCK	RockShox Deluxe Select R Debonair, 205x65mm. Settings: Low-speed rebound, air preload. Trunnion top mount, 25x10mm bottom bushings
SHOCK SETTINGS	Light compression, Light rebound, 1 Token
FORK	RockShox 35 Silver TK 29, 160mm, TurnKey, Solo Air, tapered steerer tube, Boost 15x110mm axle, 35mm steel stanchions, 44mm offset. Settings: compression adjustment at low-speed to lock, rebound, air preload
HEADSET	Onoff Saturn tapered for 1-1/8" to 1-1/2" head tube, ACB sealed bearings, top 41x30.2x7x45°x45°, bottom 51.9x40x8x45°x45°
STEM	Onoff Sulfur FG 30mm 0°, 6061 forged alloy, 31.8mm barbare
HANDLEBAR	Onoff Sulfur 1.0 double butted 6061 alloy, rise: 20mm, width: 800mm, 9° backsweep, 5° upsweep, 31.8mm barbare
GRIPS	Onoff Diamond, 1lock-on, 135mm
SEATPOST	Onoff Pija dropper internal, diameter 31.6mm, S size: 387x125mm, M size: 425x150mm, L/XL size: 465x170mm
SADDLE	Fizik Terra Aidon X5 145mm
FRONT BRAKE	Sram G2 R, 4-piston caliper, Centerline 200mm IS 6 bolts one-piece rotor, steel-backed organic pads
REAR BRAKE	Sram G2 R, 4-piston caliper, Centerline 200mm IS 6 bolts one-piece rotor, steel-backed organic pads
BRAKE LEVER	Sram G2 R, tool-free reach adjust
RIMS	MDK-HP1 29, 30mm internal width, tubeless ready, 32 spokes
SPOKES	CN round stainless steel
FRONT HUB	Formula DC711, Boost 15x110mm, sealed bearings, IS 6 bolts
REAR HUB	Formula EHL148 Boost 12x148mm, sealed bearings, IS 6 bolts

FRONT TIRE	Maxxis Rekon 29x2.6, tubeless ready, dual compound, EXO protection, 60TPI, folding bead
REAR TIRE	Maxxis Rekon 29x2.6, tubeless ready, dual compound, EXO protection, 60TPI, folding bead
CRANKSET	Race Face Aeffect ebike, 165mm
RINGS	Sram X-Sync 2 Eagle 34T, steel, narrow-wide, 104 BCD
PEDALS	---
CHAIN	Sram SX Eagle, 12s, Powerlock
FRONT DERRAILLEUR	---
REAR DERRAILLEUR	Sram SX Eagle, Type 3 roller bearing clutch, cage lock, long cage, 1x12s, X-actuation 1:1
SHIFT LEVERS	Sram Trigger SX Eagle, 12s, X-Actuation 1:1, single click
CASSETTE	Sram PG-1210, 11-50T, 12s
MOTOR	Bosch Performance Line CX Cruise (25Km/h) GEN4
BATTERY	Bosch Powertube 625Wh
DISPLAY	Bosch Purion
DERRAILLEUR HANGER	Mondraker M068
OTHERS	---
WEIGHT	---



e-MTB TRAIL

PRIME 29

Color 1: Gloss Black / Racing Silver - Color 2: Gloss Marlin Blue / Black

FRAME	Prime Xtralite 6061 Full Butted Alloy, Forward Geometry, internal removable battery, tapered head tube, Boost 12x148mm rear axle, integrated dropout speed sensor
SIZES	XS: 380mm / S: 390mm / M: 430mm / L: 470mm / XL: 510mm
REAR SHOCK	---
SHOCK SETTINGS	---
FORK	RockShox Recon Silver RL 29, 120mm, Motion control, Solo Air, tapered steerer tube, Boost 15x110mm axle, 42mm offset. Settings: compression adjustment at low-speed to lock, rebound, air preload
HEADSET	Onoff Saturn tapered for 1-1/8" to 1-1/2" head tube, ACB sealed bearings, top 41x30.2x7x45°x45°, bottom 51.9x40x8x45°x45°
STEM	Onoff Sulfur FG 30mm 0°, 6061 forged alloy, 31.8mm barbore
HANDLEBAR	Onoff Sulfur 1.0 double butted 6061 alloy, rise: 20mm, width: 800mm, 9° backsweep, 5° upsweep, 31.8mm barbore
GRIPS	Onoff Diamond, 1lock-on, 135mm
SEATPOST	Onoff Sulfur 0-R, 6061 T6 Alloy, 3D forged, diameter 31.6mm, length 400mm
SADDLE	Fizik Terra Aidon X5 145mm
FRONT BRAKE	Sram Level T, 2 piece caliper, Centerline 200mm IS 6 bolts one-piece rotor, steel-backed organic pad
REAR BRAKE	Sram Level T, 2 piece caliper, Centerline 180mm IS 6 bolts one-piece rotor, steel-backed organic pad
BRAKE LEVER	Sram Level T, Direct Link actuation, tooling reach adjust, lever pivot bushings
RIMS	MDK-HP1 29, 30mm internal width, tubeless ready, 32 spokes
SPOKES	CN round stainless steel
FRONT HUB	Formula DC711, Boost 15x110mm, sealed bearings, IS 6 bolts
REAR HUB	Formula EHL148 Boost 12x148mm, sealed bearings, IS 6 bolts

FRONT TIRE	Maxxis Rekon 29x2.6, tubeless ready, dual compound, EXO protection, 60TPI, folding bead
REAR TIRE	Maxxis Rekon 29x2.6, tubeless ready, dual compound, EXO protection, 60TPI, folding bead
CRANKSET	Race Face Aeffect ebike, 165mm
RINGS	Sram X-Sync 2 Eagle 34T, steel, narrow-wide, 104 BCD
PEDALS	---
CHAIN	Sram SX Eagle, 12s, Powerlock
FRONT DERRAILLEUR	---
REAR DERRAILLEUR	Sram SX Eagle, Type 3 roller bearing clutch, cage lock, long cage, 1x12s, X-actuation 1:1
SHIFT LEVERS	Sram Trigger SX Eagle, 12s, X-Actuation 1:1, single click
CASSETTE	Sram PG-1210, 11-50T, 12s
MOTOR	Bosch Performance Line CX Cruise (25Km/h) GEN4
BATTERY	Bosch Powertube 625Wh
DISPLAY	Bosch Purion
DERAILLEUR HANGER	Mondraker M068
OTHERS	---
WEIGHT	---



e-MTB TRAIL

PRIME +

Color 1: Gloss Black / Racing Silver - Color 2: Gloss Marlin Blue / Black

FRAME	Prime 6061 Xtralite Full Butted Alloy, Forward Geometry, internal removable battery, tapered head tube, Boost 12x148mm rear axle, integrated dropout speed sensor
SIZES	XS: 380mm / S: 390mm / M: 430mm / L: 470mm / XL: 510mm
REAR SHOCK	---
SHOCK SETTINGS	---
FORK	RockShox Recon Silver RL 29, 120mm, Motion control, Solo Air, tapered steerer tube, Boost 15x110mm axle, 42mm offset. Settings: compression adjustment at low-speed to lock, rebound, air preload
HEADSET	Onoff Saturn tapered for 1-1/8" to 1-1/2" head tube, ACB sealed bearings, top 41x30.2x7x45°x45°, bottom 51.9x40x8x45°x45°
STEM	Onoff Sulfur FG 30mm 0°, 6061 forged alloy, 31.8mm bar bore
HANDLEBAR	Onoff Sulfur 1.0 double butted 6061 alloy, rise: 20mm, width: 800mm, 9° backsweep, 5° upsweep, 31.8mm bar bore
GRIPS	Onoff Diamond, 1lock-on, 135mm
SEATPOST	Onoff Sulfur 0-R, 6061 T6 Alloy, 3D forged, diameter 31.6mm, length 400mm
SADDLE	Fizik Terra Aidon X5 145mm
FRONT BRAKE	Sram Level T, 2 piece caliper, Centerline 200mm IS 6 bolts one-piece rotor, steel-backed organic pad
REAR BRAKE	Sram Level T, 2 piece caliper, Centerline 180mm IS 6 bolts one-piece rotor, steel-backed organic pad
BRAKE LEVER	Sram Level T, Direct Link actuation, tooling reach adjust, lever pivot bushings
RIMS	MDK-HP1 27.5+, 35mm internal width, tubeless ready, 32 spokes
SPOKES	CN round stainless steel
FRONT HUB	Formula DC711, Boost 15x110mm, sealed bearings, IS 6 bolts
REAR HUB	Formula EHL148 Boost 12x148mm, sealed bearings, IS 6 bolts

FRONT TIRE	Maxxis Rekon+ 27.5x2.8, tubeless ready, dual compound, EXO protection, 60TPI, folding bead
REAR TIRE	Maxxis Rekon+ 27.5x2.8, tubeless ready, dual compound, EXO protection, 60TPI, folding bead
CRANKSET	Race Face Aeffect ebike, 165mm
RINGS	Sram X-Sync 2 Eagle 34T, steel, narrow-wide, 104 BCD
PEDALS	---
CHAIN	Sram SX Eagle, 12s, Powerlock
FRONT DERRAILLEUR	---
REAR DERRAILLEUR	Sram SX Eagle, Type 3 roller bearing clutch, cage lock, long cage, 1x12s, X-actuation 1:1
SHIFT LEVERS	Sram Trigger SX Eagle, 12s, X-Actuation 1:1, single click
CASSETTE	Sram PG-1210, 11-50T, 12s
MOTOR	Bosch Performance Line CX Cruise (25Km/h) GEN4
BATTERY	Bosch Powertube 625Wh
DISPLAY	Bosch Purion
DERAILLEUR HANGER	Mondraker M068
OTHERS	---
WEIGHT	---



e-MTB TRAIL

PRIME X

Color 1: Matte Graphite / Desert Grey - Color 2: Gloss Black / Frost Green

FRAME	Prime 6061 Xtralite Full Butted Alloy, Forward Geometry, internal removable battery, tapered head tube, Boost 12x148mm rear axle, integrated dropout speed sensor
SIZES	XS: 380mm / S: 390mm / M: 430mm / L: 470mm / XL: 510mm
REAR SHOCK	---
SHOCK SETTINGS	---
FORK	RockShox Recon Silver RL 29, 120mm, Motion control, Solo Air, tapered steerer tube, Boost 15x110mm axle, 42mm offset. Settings: compression adjustment at low-speed to lock, rebound, air preload
HEADSET	Onoff Saturn tapered for 1-1/8" to 1-1/2" head tube, ACB sealed bearings, top 41x30.2x7x45°x45°, bottom 51.9x40x8x45°x45°
STEM	MDK Urban 35mm, 6061 forged alloy, 31.8mm bar bore
HANDLEBAR	Onoff Sulfur 1.0 double butted 6061 alloy, rise: 20mm, width: 680mm, 9° backsweep, 5° upsweep, 31.8mm bar bore
GRIPS	Onoff Shaper
SEATPOST	Onoff Sulfur 0-R, 6061 T6 Alloy, 3D forged, diameter 31.6mm, length 400mm
SADDLE	Fizik Terra Aidon X5 145mm
FRONT BRAKE	Sram Level T, 2 piece caliper, Centerline 200mm IS 6 bolts one-piece rotor, steel-backed organic pad
REAR BRAKE	Sram Level T, 2 piece caliper, Centerline 180mm IS 6 bolts one-piece rotor, steel-backed organic pad
BRAKE LEVER	Sram Level T, Direct Link actuation, tooling reach adjust, lever pivot bushings
RIMS	MDK-HP1 29, 30mm internal width, tubeless ready, 32 spokes
SPOKES	CN round stainless steel
FRONT HUB	Formula DC711, Boost 15x110mm, sealed bearings, IS 6 bolts
REAR HUB	Formula EHL148 Boost 12x148mm, sealed bearings, IS 6 bolts

FRONT TIRE	Maxxis Gritter 29x2.5, single compound, 60TPI, wire bead, tanned wall
REAR TIRE	Maxxis Gritter 29x2.5, single compound, 60TPI, wire bead, tanned wall
CRANKSET	Race Face Aeffect ebike, 165mm
RINGS	Sram X-Sync 2 Eagle 34T, steel, narrow-wide, 104 BCD
PEDALS	Sram SX Eagle, 12s, Powerlock
CHAIN	Sram SX Eagle, Type 3 roller bearing clutch, cage lock, long cage, 1x12s, X-actuation 1:1
FRONT DERRAILLEUR	---
REAR DERRAILLEUR	Sram Trigger SX Eagle, 12s, X-Actuation 1:1, single click
SHIFT LEVERS	---
CASSETTE	Sram PG-1210, 11-50T, 12s
MOTOR	Bosch Performance Line CX Cruise (25Km/h) GEN4
BATTERY	Bosch Powertube 625Wh
DISPLAY	Bosch Purion
DERRAILLEUR HANGER	Mondraker M068
OTHERS	Front light: 50LUX output DC 6-12V, waterproof Alloy cage. Rear Light: Fender Mount, w/ Reflective, e-bike version, 6-12V. Fenders: Alloy black MDK custom fenders. Rack: Alloy MDK rear Rack, Max loading 25kg. Kickstand: Massload KSA18-40
WEIGHT	---



e-MTB TRAIL

THUNDRA

Gloss Graphite / Racing Silver

FRAME	Thundra 6061 Xtralite Full Butted Alloy, Forward Geometry, integrated internal non-removable battery, tapered head tube, Boost 12x148mm rear axle, integrated dropout speed sensor. *Optional external battery
SIZES	XS: 380mm / S: 390mm / M: 430mm / L: 470mm / XL: 510mm
REAR SHOCK	---
SHOCK SETTINGS	---
FORK	RockShox Recon Silver RL 29, 120mm, Motion control, Solo Air, tapered steerer tube, Boost 15x110mm axle, 42mm offset. Settings: compression adjustment at low-speed to lock, rebound, air preload
HEADSET	Onoff Saturn tapered for 1-1/8" to 1-1/2" head tube, ACB sealed bearings, top 41x30.2x7x45°x45°, bottom 51.9x40x8x45°x45°
STEM	Onoff Sulfur FG 30mm 0°, 6061 forged alloy, 31.8mm barbare
HANDLEBAR	Onoff Sulfur 1.0 double butted 6061 alloy, rise: 20mm, width: 780mm, 9° backsweep, 5° upsweep, 31.8mm barbare
GRIPS	Onoff Diamond, 1lock-on, 135mm
SEATPOST	Onoff Sulfur 0-R, 6061 T6 Alloy, 3D forged, diameter 31.6mm, length 400mm
SADDLE	Fizik Terra Aidon X5 145mm
FRONT BRAKE	Sram Level T, 2 piece caliper, Centerline 200mm IS 6 bolts one-piece rotor, steel-backed organic pad
REAR BRAKE	Sram Level T, 2 piece caliper, Centerline 180mm IS 6 bolts one-piece rotor, steel-backed organic pad
BRAKE LEVER	Sram Level T, Direct Link actuation, tooled reach adjust, lever pivot bushings
RIMS	MDK-HP1 29, 30mm internal width, tubeless ready, 32 spokes
SPOKES	CN round stainless steel
FRONT HUB	Formula DC711, Boost 15x110mm, sealed bearings, IS 6 bolts
REAR HUB	Formula EHL148 Boost 12x148mm, sealed bearings, IS 6 bolts

FRONT TIRE	Maxxis Rekon 29x2.6, tubeless ready, dual compound, EXO protection, 60TPI, folding bead
REAR TIRE	Maxxis Rekon 29x2.6, tubeless ready, dual compound, EXO protection, 60TPI, folding bead
CRANKSET	FSA, 165mm
RINGS	Sram X-Sync 2 Eagle 34T, steel, narrow-wide, 104 BCD
PEDALS	Sram SX Eagle, 12s, Powerlock
CHAIN	---
FRONT DERRAILLEUR	Sram SX Eagle, Type 3 roller bearing clutch, cage lock, long cage, 1x12s, X-actuation 1:1
REAR DERRAILLEUR	----
SHIFT LEVERS	Sram Trigger SX Eagle, 12s, X-Actuation 1:1, single click
CASSETTE	Sram PG-1210, 11-50T, 12s
MOTOR	Shimano STEPS E7000
BATTERY	Simplo internal 630Wh
DISPLAY	Shimano STEPS E5003
DERRAILLEUR HANGER	Mondraker M068
OTHERS	*Optional external battery: Simplo 360Wh
WEIGHT	---



e-MTB TRAIL

THUNDRA X

Matte Black / Graphite

FRAME	Thundra 6061 Xtralite Full Butted Alloy, Forward Geometry, integrated internal non-removable battery, tapered head tube, Boost 12x148mm rear axle, integrated dropout speed sensor. *Optional external battery
SIZES	XS: 380mm / S: 390mm / M: 430mm / L: 470mm / XL: 510mm
REAR SHOCK	---
SHOCK SETTINGS	---
FORK	RockShox Recon Silver RL 29, 120mm, Motion control, Solo Air, tapered steerer tube, Boost 15x110mm axle, 42mm offset. Settings: compression adjustment at low-speed to lock, rebound, air preload
HEADSET	Onoff Saturn tapered for 1-1/8" to 1-1/2" head tube, ACB sealed bearings, top 41x30.2x7x45°x45°, bottom 51.9x40x8x45°x45°
STEM	MDK Urban 35mm, 6061 forged alloy, 31.8mm barbore
HANDLEBAR	Onoff Sulfur 1.0 double butted 6061 alloy, rise: 20mm, width: 680mm, 9° backsweep, 5° upsweep, 31.8mm barbore
GRIPS	Onoff Diamond, 1lock-on, 135mm
SEATPOST	Onoff Sulfur 0-R, 6061 T6 Alloy, 3D forged, diameter 31.6mm, length 400mm
SADDLE	Fizik Terra Aidon X5 145mm
FRONT BRAKE	Sram Level T, 2 piece caliper, Centerline 200mm IS 6 bolts one-piece rotor, steel-backed organic pad
REAR BRAKE	Sram Level T, 2 piece caliper, Centerline 180mm IS 6 bolts one-piece rotor, steel-backed organic pad
BRAKE LEVER	Sram Level T, Direct Link actuation, tooled reach adjust, lever pivot bushings
RIMS	MDK-HP1 29, 30mm internal width, tubeless ready, 32 spokes
SPOKES	CN round stainless steel
FRONT HUB	Formula DC711, Boost 15x110mm, sealed bearings, IS 6 bolts
REAR HUB	Formula EHL148 Boost 12x148mm, sealed bearings, IS 6 bolts

FRONT TIRE	Maxxis Gritter 29x2.5, single compound, 60TPI, wire bead, tanned wall
REAR TIRE	Maxxis Gritter 29x2.5, single compound, 60TPI, wire bead, tanned wall
CRANKSET	FSA, 165mm
RINGS	Sram X-Sync 2 Eagle 34T, steel, narrow-wide, 104 BCD
PEDALS	---
CHAIN	Sram SX Eagle, 12s, Powerlock
FRONT DERRAILLEUR	---
REAR DERRAILLEUR	Sram SX Eagle, Type 3 roller bearing clutch, cage lock, long cage, 1x12s, X-actuation 1:1
SHIFT LEVERS	Sram Trigger SX Eagle, 12s, X-Actuation 1:1, single click
CASSETTE	Sram PG-1210, 11-50T, 12s
MOTOR	Shimano STEPS E7000
BATTERY	Simplo internal 630Wh
DISPLAY	Shimano STEPS E5003
DERRAILLEUR HANGER	Mondraker M068
OTHERS	Front light: 50LUX output DC 6-12V, waterproof Alloy cage. Rear Light: Fender Mount, w/ Reflective, e-bike version, 6-12V. Fenders: Alloy black MDK custom fenders. Rack: Alloy MDK rear Rack, Max loading 25kg. Kickstand: Massload KSA18-40. *Optional external battery: Simplo 360Wh
WEIGHT	---



KIDS

FACTOR 26

Gloss Black / Racing Silver

FRAME	Factor 26 6061 Alloy Stealth Evo, hydroformed tubing, Zero Suspension System, 120mm travel, one piece bolt-on upper link, QR 9mm rear axle, 73mm BSA bottom bracket, HHG internal cable routing, dedicated 1x drivetrain design
SIZES	One size: 350mm
REAR SHOCK	X-Fusion O2PRO R, 210x55mm. Settings: low-speed rebound, air preload. 45x8mm top and bottom bushings
SHOCK SETTINGS	A-Tune light compression
FORK	X-Fusion Velvet RL2 26, 120mm, air spring, tapered steerer tube, 9x100mm axle, 32mm aluminum stanchions, 41mm offset. Settings: lockout, rebound, air preload
HEADSET	Onoff Saturn tapered for 1-1/8" to 1-1/2" head tube, ACB sealed bearings, top 41x30.2x7x45°x45°, bottom 51.9x40x8x45°x45°
STEM	Onoff Sulfur FG 30mm 0°, 6061 forged alloy, 31.8mm barbare
HANDLEBAR	SDG Slater, double butted 6061 alloy, rise: 20mm, width: 650mm, 5° backsweep, 8° upsweep, 31.8mm barbare with 4x19mm shims
GRIPS	Onoff Diamond, 1lock-on
SEATPOST	Onoff Sulfur 0-R, 6061 T6 Alloy, 3D forged, diameter 31.6mm, length 400mm
SADDLE	SDG Fly JR
FRONT BRAKE	Sram Level, 2 piece caliper, Centerline 160mm IS 6 bolts one-piece rotor, steel-backed organic pad
REAR BRAKE	Sram Level, 2 piece caliper, Centerline 160mm IS 6 bolts one-piece rotor, steel-backed organic pad
BRAKE LEVER	Sram Level, tooled reach adjust, lever pivot bushings
RIMS	MDK-XP1 26 TLR, 23mm internal width, tubeless ready, 32 spokes
SPOKES	CN round stainless steel
FRONT HUB	Formula DC20LW, 9x100mm, cup & cone ball bearings, IS 6 bolts
REAR HUB	Formula DC22LW 9x135mm, cup & cone ball bearings, IS 6 bolts

FRONT TIRE	Kenda Booster 26x2.4 single compound 30TPI, wire bead
REAR TIRE	Kenda Booster 26x2.4 single compound 30TPI, wire bead
CRANKSET	Sram SX Eagle, DUB axle, Direct mount chain ring, 155mm
RINGS	30T, steel, X-Sync
BOTTOM BRACKET	Sram DUB BSA, sealed bearings, 73mm
PEDALS	---
CHAIN	Sram SX Eagle, 12s, Powerlock
FRONT DERRAILLEUR	---
REAR DERRAILLEUR	Sram SX Eagle, Type 3 roller bearing clutch, cage lock, long cage, 1x12s, X-actuation 1:1
SHIFT LEVERS	Sram Trigger SX Eagle, 12s, X-Actuation 1:1
CASSETTE	Sram XG-1230, 11-50T, 12s
DERAILLEUR HANGER	Mondraker M073
OTHERS	---
WEIGHT	---



KIDS

FACTOR 24

Gloss Deep Purple / Flame Red

FRAME	Factor 24 6061 Alloy Stealth Evo, hydroformed tubing, Zero Suspension System, 100mm travel, one piece bolt-on upper link, QR 9mm rear axle, 73mm BSA bottom bracket, HHG internal cable routing, dedicated 1x drivetrain design. 26" wheelset compatible
SIZES	One size: 300mm
REAR SHOCK	X-Fusion O2PRO R, 210x47.5mm. Settings: low-speed rebound, air preload. 45x8mm top and bottom bushings
SHOCK SETTINGS	A-Tune light compression
FORK	X-Fusion Velvet RL 26, 100mm, air spring, tapered steerer tube, 9x100mm axle, 32mm aluminum stanchions, 41mm offset. Settings: lockout, rebound, air preload
HEADSET	Onoff Saturn tapered for 1-1/8" to 1-1/2" head tube, ACB sealed bearings, top 41x30.2x7x45°x45°, bottom 51.9x40x8x45°x45°
STEM	Onoff Sulfur FG 30mm 0°, 6061 forged alloy, 31.8mm barbare
HANDLEBAR	SDG Slater, double butted 6061 alloy, rise: 20mm, width: 650mm, 5° backsweep, 8° upsweep, 31.8mm barbare with 4x19mm shims
GRIPS	Onoff Diamond, 1lock-on
SEATPOST	Onoff Sulfur 0-R, 6061 T6 Alloy, 3D forged, diameter 31.6mm, length 400mm
SADDLE	SDG Fly JR
FRONT BRAKE	Sram Level, 2 piece caliper, Centerline 160mm IS 6 bolts one-piece rotor, steel-backed organic pad
REAR BRAKE	Sram Level, 2 piece caliper, Centerline 160mm IS 6 bolts one-piece rotor, steel-backed organic pad
BRAKE LEVER	Sram Level, tooled reach adjust, lever pivot bushings
RIMS	MDK-XP1 24 TLR, 23mm internal width, tubeless ready, 32 spokes
SPOKES	CN round stainless steel
FRONT HUB	Formula DC20LW, 9x100mm, cup & cone ball bearings, IS 6 bolts
REAR HUB	Formula DC22LW 9x135mm, cup & cone ball bearings, IS 6 bolts

FRONT TIRE	Kenda Booster 24x2.4 single compound 30TPI, wire bead
REAR TIRE	Kenda Booster 24x2.4 single compound 30TPI, wire bead
CRANKSET	Sram SX Eagle, DUB axle, Direct mount chain ring, 155mm
RINGS	30T, steel, X-Sync
BOTTOM BRACKET	Sram DUB BSA, sealed bearings, 73mm
PEDALS	---
CHAIN	Sram SX Eagle, 12s, Powerlock
FRONT DERRAILLEUR	---
REAR DERRAILLEUR	Sram SX Eagle, Type 3 roller bearing clutch, cage lock, long cage, 1x12s, X-actuation 1:1
SHIFT LEVERS	Sram Trigger SX Eagle, 12s, X-Actuation 1:1
CASSETTE	Sram PG-1230, 11-50T, 12s
DERAILLEUR HANGER	Mondraker M073
OTHERS	---
WEIGHT	---



KIDS

LEADER 26

Gloss Racing Silver / Marlin Blue

FRAME	Leader 26 7005 Alloy Stealth Evo, HHG internal cable routing, internal headset, replaceable hanger, BSA bottom bracket, QR 9mm rear axle
SIZES	One size 320mm
REAR SHOCK	---
SHOCK SETTINGS	---
FORK	Suntour XCE28 DS 26" 100mm, soft spring. Settings: spring preload
HEADSET	CH-9280, Internal ZS, 44mm external diameter cup
STEM	MDK XC, 6061 forged alloy, 25.4mm bar bore, rise: 0°, length: 45mm
HANDLEBAR	MDK XC 1.0, 6061 alloy, rise: 25mm, width: 620mm, 9° backsweep, 5° upsweep, 25.4mm bar bore
GRIPS	Onoff Diamond, 86mm
SEATPOST	MDK XC, 6061 T6 alloy, diameter 27.2mm, length 300mm, offset 15mm
SADDLE	Mondraker Leader Kids series
FRONT BRAKE	Tektro M291 Auriga 160mm
REAR BRAKE	Tektro M291 Auriga 160mm
BRAKE LEVER	Tektro M291 Auriga
RIMS	MDK-26 Alloy, 32 spokes
SPOKES	CN round stainless steel
FRONT HUB	Formula DC20FQR, 9x100mm QR axle, cup & cone ball bearings
REAR HUB	Formula DC22LW QR, 9x135mm QR axle, cup & cone ball bearings

FRONT TIRE	Kenda Small Block Eight 26x2.35, single compound, 30TPI, wire bead
REAR TIRE	Kenda Small Block Eight 26x2.35, single compound, 30TPI, wire bead
CRANKSET	Prowheel PRO, 152mm
RINGS	36T
BOTTOM BRACKET	CH-52
PEDALS	Wellgo LU-205
CHAIN	KMC Z-8.1, 8s
FRONT DERRAILLEUR	---
REAR DERRAILLEUR	Microshift Acolyte RDM5180M 1x8
SHIFT LEVERS	Microshift Acolyte RDM5180M 1x8 Direct Cable Pull Design
CASSETTE	Microshift Acolyte CSH083 12-42 Black
DERAILLEUR HANGER	Mondraker M073
OTHERS	---
WEIGHT	---



KIDS

LEADER 24

Gloss Black / Cherry Red

FRAME	Leader 24 7005 Alloy Stealth Evo, HHG internal cable routing, internal headset, replaceable hanger, BSA bottom bracket, QR 9mm rear axle
SIZES	One size 320mm
REAR SHOCK	---
SHOCK SETTINGS	---
FORK	MDK 24 Kid, Alloy stanchions, Chromoly steering tube
HEADSET	CH-9280, Internal ZS, 44mm external diameter cup
STEM	MDK XC, 6061 forged alloy, 25.4mm bar bore, rise: 0°, length: 45mm
HANDLEBAR	MDK XC 1.0, 6061 alloy, rise: 25mm, width: 620mm, 9° backsweep, 5° upsweep, 25.4mm bar bore
GRIPS	Onoff Diamond, 86mm
SEATPOST	MDK XC, 6061 T6 alloy, diameter 27.2mm, length 300mm, offset 15mm
SADDLE	Mondraker Leader Kids series
FRONT BRAKE	Tektro M291 Auriga 160mm
REAR BRAKE	Tektro M291 Auriga 160mm
BRAKE LEVER	Tektro M291 Auriga
RIMS	MDK-24 Alloy, 32 spokes
SPOKES	CN round stainless steel
FRONT HUB	Formula OV31FQR, 9x100mm QR axle, cup & cone ball bearings
REAR HUB	Formula OV30-8RQR, 9x135mm QR axle, cup & cone ball bearings

FRONT TIRE	Kenda Small Block Eight 24x2.1, single compound, 30TPI, wire bead
REAR TIRE	Kenda Small Block Eight 24x2.1, single compound, 30TPI, wire bead
CRANKSET	Prowheel PRO, 152mm
RINGS	36T
BOTTOM BRACKET	CH-52
PEDALS	Wellgo LU-205
CHAIN	KMC Z-8.1, 8s
FRONT DERRAILLEUR	---
REAR DERRAILLEUR	Microshift Acolyte RDM5180M 1X8
SHIFT LEVERS	Microshift Acolyte RDM5180M 1X8 Direct Cable Pull Design
CASSETTE	Microshift Acolyte CSH083 12-42 Black
DERAILLEUR HANGER	Mondraker M073
OTHERS	---
WEIGHT	---



KIDS

LEADER 20

Gloss Racing Silver / Yellow

FRAME	Leader 20 7005 Alloy Stealth Evo, HHG internal cable routing, internal headset, replaceable hanger, BSA bottom bracket, QR 9mm rear axle
SIZES	One size 260mm
REAR SHOCK	---
SHOCK SETTINGS	---
FORK	MDK 20 Kid, Alloy stanchions, Chromoly steering tube
HEADSET	CH-9280, Internal ZS, 44mm external diameter cup
STEM	MDK XC, 6061 forged alloy, 25.4mm bar bore, rise: 0°, length: 35mm
HANDLEBAR	MDK XC 1.0, 6061 alloy, rise: 25mm, width: 560mm, 9° backsweep, 5° upsweep, 25.4mm bar bore
GRIPS	Onoff Diamond, 75mm
SEATPOST	MDK XC, 6061 T6 alloy, diameter 27.2mm, length 250mm, offset 15mm
SADDLE	Mondraker Leader Kids series
FRONT BRAKE	Tektro Alloy V-Brake
REAR BRAKE	Tektro Alloy V-Brake
BRAKE LEVER	Tektro 2-finger kids
RIMS	MDK-20 Alloy, 32 spokes
SPOKES	CN round stainless steel
FRONT HUB	Formula OV31FQR, 9x100mm QR axle, cup & cone ball bearings
REAR HUB	Formula OV31RQR, 9x135mm QR axle, cup & cone ball bearings

FRONT TIRE	Kenda Small Block Eight 20x2.1, single compound, 30TPI, wire bead
REAR TIRE	Kenda Small Block Eight 20x2.1, single compound, 30TPI, wire bead
CRANKSET	Prowheel, 140mm
RINGS	36T
BOTTOM BRACKET	CH-52
PEDALS	Wellgo LU-P28
CHAIN	KMC Z-7, 7s
FRONT DERRAILLEUR	---
REAR DERRAILLEUR	Shimano TY200-SS, super short cage, 7s
SHIFT LEVERS	Shimano RV200-7R, Revoshift, 7s
CASSETTE	Shimano TZ510-7, 14-28T, 7s
DERRAILLEUR HANGER	Mondraker M073
OTHERS	---
WEIGHT	---



KIDS

LEADER 16

Gloss Frost Green / Black

FRAME	Leader 16 7005 Alloy Stealth Evo, HHG internal cable routing, internal headset, replaceable hanger, BSA bottom bracket, QR 9mm rear axle
SIZES	One size 210mm
REAR SHOCK	---
SHOCK SETTINGS	---
FORK	MDK 16 Kid, Alloy stanchions, Chromoly steering tube
HEADSET	CH-9280, Internal ZS, 44mm external diameter cup
STEM	MDK XC, 6061 forged alloy, 25.4mm bar bore, rise: 0°, length: 35mm
HANDLEBAR	MDK XC 1.0, 6061 alloy, rise: 25mm, width: 500mm, 9° backsweep, 5° upsweep, 25.4mm bar bore
GRIPS	Onoff Diamond, 75mm
SEATPOST	MDK XC, 6061 T6 alloy, diameter 27.2mm, length 200mm, offset 15mm
SADDLE	Mondraker Leader Kids series
FRONT BRAKE	Tektro Alloy V-Brake
REAR BRAKE	Tektro Alloy V-Brake
BRAKE LEVER	Tektro 2-finger kids
RIMS	MDK-16 Alloy, 32 spokes
SPOKES	CN round stainless steel
FRONT HUB	Formula OV31FQR, 9x100mm QR axle, cup & cone ball bearings
REAR HUB	Formula OV31RQR, 9x135mm QR axle, cup & cone ball bearings

FRONT TIRE	Kenda Kaos 16x2.1, single compound, 30TPI, wire bead
REAR TIRE	Kenda Kaos 16x2.1, single compound, 30TPI, wire bead
CRANKSET	Prowheel, 102mm
RINGS	32T
BOTTOM BRACKET	CH-52
PEDALS	Wellgo LU-P28
CHAIN	KMC Z-6, 6s
FRONT DERRAILLEUR	---
REAR DERRAILLEUR	Shimano TY200-SS, super short cage, 6s
SHIFT LEVERS	Shimano RV200-6R, Revoshift, 6s
CASSETTE	Shimano TZ510-6, 14-28T, 6s
DERRAILLEUR HANGER	Mondraker M073
OTHERS	---
WEIGHT	---



e-KIDS

F-PLAY 26

Gloss Racing Silver / Black

FRAME	F-Play 26 6061 Alloy Stealth evo, hydroformed tubing, Zero Suspension System, 120mm travel, one piece bolt-on upper link, integrated internal non-removable battery, Tapered head tube, HHG internal cable routing, BSA bottom bracket, QR 9mm rear axle, 1x drivetrain compatible
SIZES	One size: 350mm
REAR SHOCK	X-Fusion O2PRO R, 210x55mm. Settings: low-speed rebound, air preload. 45x8mm top and bottom bushings
SHOCK SETTINGS	A-Tune light compression
FORK	X-Fusion Velvet RL 26, 120mm, air spring, tapered steerer tube, 9x100mm axle, 32mm aluminum stanchions, 41mm offset. Settings: lockout, rebound, air preload
HEADSET	Onoff Saturn tapered for 1-1/8" to 1-1/2" head tube, ACB sealed bearings, top 41x30.2x7x45°x45°, bottom 51.9x40x8x45°x45°
STEM	Onoff Sulfur FG 30mm 0°, 6061 forged alloy, 31.8mm barbore
HANDLEBAR	MDK XC 1.0, 6061 alloy, rise: 25mm, width: 680mm, 9° backsweep, 5° upsweep, 31.8mm barbore
GRIPS	Onoff Diamond, 1lock-on
SEATPOST	MDK XC 0-R, 6061 T6 Alloy, diameter 31.6mm, length 350mm
SADDLE	SDG Fly JR
FRONT BRAKE	Sram Level, 2 piece caliper, Centerline 160mm IS 6 bolts one-piece rotor, steel-backed organic pad
REAR BRAKE	Sram Level, 2 piece caliper, Centerline 160mm IS 6 bolts one-piece rotor, steel-backed organic pad
BRAKE LEVER	Sram Level, tooled reach adjust, lever pivot bushings
RIMS	MDK-XP1 26 TLR, 25mm internal width, tubeless ready, 32 spokes
SPOKES	CN round stainless steel
FRONT HUB	Formula DC20LW, 9x100mm, cup & cone ball bearings, IS 6 bolts
REAR HUB	Mahle-Ebikemotion X-35

FRONT TIRE	Kenda Booster 26x2.4 single compound 30TPI, wire bead
REAR TIRE	Kenda Booster 26x2.4 single compound 30TPI, wire bead
CRANKSET	Sram SX Eagle, DUB axle, Direct mount chain ring, 155mm
RINGS	30T, steel, X-Sync
BOTTOM BRACKET	Sram DUB BSA, sealed bearings, 73mm
PEDALS	---
CHAIN	Sram SX Eagle, 12s, Powerlock
FRONT DERRAILLEUR	---
REAR DERRAILLEUR	Sram SX Eagle, Type 3 roller bearing clutch, cage lock, long cage, 1x12s, X-actuation 1:1
SHIFT LEVERS	Sram Trigger SX Eagle, 12s, X-Actuation 1:1
CASSETTE	Sram XG-1230, 11-50T, 12s
MOTOR	Mahle-Ebikemotion X-35
BATTERY	Mahle-Ebikemotion Internal 250Wh
DISPLAY	Mahle-Ebikemotion
DERAILLEUR HANGER	Mondraker M073
OTHERS	---
WEIGHT	---



e-KIDS

F-PLAY 24

Gloss Cherry Red / Black

FRAME	F-Play 24 6061 Alloy Stealth evo, hydroformed tubing, Zero Suspension System, 120mm travel, one piece bolt-on upper link, integrated internal non-removable battery, Tapered head tube, HHG internal cable routing, BSA bottom bracket, QR 9mm rear axle, 1x drivetrain compatible
SIZES	One size: 300mm
REAR SHOCK	X-Fusion 02PRO R, 210x47.5mm. Settings: low-speed rebound, air preload. 45x8mm top and bottom bushings
SHOCK SETTINGS	---
FORK	RockShox Judy Silver TK 26, 100mm, TurnKey, Solo Air, tapered steerer tube, 9x100mm axle, 30mm steel stanchions, 40mm offset. Settings: compression adjustment at low-speed to lock, rebound, air preload
HEADSET	Onoff Saturn tapered for 1-1/8" to 1-1/2" head tube, ACB sealed bearings, top 41x30.2x7x45°x45°, bottom 51.9x40x8x45°x45°
STEM	Onoff Sulfur FG 30mm 0°, 6061 forged alloy, 31.8mm barbore
HANDLEBAR	MDK XC 1.0, 6061 alloy, rise: 25mm, width: 680mm, 9° backsweep, 5° upsweep, 31.8mm barbore
GRIPS	Onoff Twin, 1lock-on, 135mm
SEATPOST	MDK XC 0-R, 6061 T6 Alloy, diameter 31.6mm, length 300mm
SADDLE	SDG Fly JR
FRONT BRAKE	Sram Level, 2 piece caliper, Centerline 160mm IS 6 bolts one-piece rotor, steel-backed organic pad
REAR BRAKE	Sram Level, 2 piece caliper, Centerline 160mm IS 6 bolts one-piece rotor, steel-backed organic pad
BRAKE LEVER	Sram Level, tooled reach adjust, lever pivot bushings
RIMS	MDK-XP1 24 TLR, 25mm internal width, tubeless ready, 32 spokes
SPOKES	CN round stainless steel
FRONT HUB	Formula DC20LW, 9x100mm, cup & cone ball bearings, IS 6 bolts
REAR HUB	Mahle-Ebikemotion X-35

FRONT TIRE	Kenda Booster 24x2.4 single compound 30TPI, wire bead
REAR TIRE	Kenda Booster 24x2.4 single compound 30TPI, wire bead
CRANKSET	Prowheel, Direct mount chain ring, 150mm
RINGS	30T, steel
BOTTOM BRACKET	Samox BSA, 73mm
PEDALS	---
CHAIN	Sram PC1031 10s, Powerlock
FRONT DERRAILLEUR	---
REAR DERRAILLEUR	Sram GX, 10s, short cage, X-actuation 1:1
SHIFT LEVERS	Sram trigger GX 10s, X-actuation 1:1
CASSETTE	Sram PG 1020 11-36T, 10s
MOTOR	Mahle-Ebikemotion X-35
BATTERY	Mahle-Ebikemotion Internal 250Wh
DISPLAY	Mahle-Ebikemotion
DERAILLEUR HANGER	Mondraker M073
OTHERS	---
WEIGHT	---



e-KIDS

PLAY 26

Gloss Black / Graphite

FRAME	Play 26 6061 Alloy Stealth evo, hydroformed tubing, integrated internal non-removable battery, Tapered head tube, HHG internal cable routing, BSA bottom bracket, QR 9mm rear axle, 1x drivetrain compatible
SIZES	One size: 350mm
REAR SHOCK	---
SHOCK SETTINGS	---
FORK	RockShox Judy Silver TK 26, 100mm, TurnKey, Solo Air, tapered steerer tube, 9x100mm axle, 30mm steel stanchions, 40mm offset. Settings: compression adjustment at low-speed to lock, rebound, air preload
HEADSET	Onoff Saturn tapered for 1-1/8" to 1-1/2" head tube, ACB sealed bearings, top 41x30.2x7x45°x45°, bottom 51.9x40x8x45°x45°
STEM	MDK XC, 6061 forged alloy, 31.8mm barbore, rise: 0°, length: 35mm
HANDLEBAR	MDK XC 1.0, 6061 alloy, rise: 25mm, width: 650mm, 9° backsweep, 5° upsweep, 31.8mm barbore
GRIPS	Onoff Twin, 1lock-on, 135mm
SEATPOST	MDK XC 0-R, 6061 T6 Alloy, diameter 31.6mm, length 350mm
SADDLE	SDG Fly JR
FRONT BRAKE	Sram Level, 2 piece caliper, Centerline 160mm IS 6 bolts one-piece rotor, steel-backed organic pad
REAR BRAKE	Sram Level, 2 piece caliper, Centerline 160mm IS 6 bolts one-piece rotor, steel-backed organic pad
BRAKE LEVER	Sram Level, tooled reach adjust, lever pivot bushings
RIMS	MDK-XP1 26 TLR, 25mm internal width, tubeless ready, 32 spokes
SPOKES	CN round stainless steel
FRONT HUB	Formula DC20LW, 9x100mm, cup & cone ball bearings, IS 6 bolts
REAR HUB	Mahle-Ebikemotion X-35

FRONT TIRE	Kenda Booster 26x2.4 single compound 30TPI, wire bead
REAR TIRE	Kenda Booster 26x2.4 single compound 30TPI, wire bead
CRANKSET	Prowheel, Direct mount chain ring, 150mm
RINGS	30T, steel
BOTTOM BRACKET	Samox BSA, 73mm
PEDALS	---
CHAIN	Sram PC1110 11s, Powerlock
FRONT DERRAILLEUR	---
REAR DERRAILLEUR	Sram NX, 11s, long cage, X-actuation 1:1
SHIFT LEVERS	Sram trigger NX 11s, X-actuation 1:1
CASSETTE	Sram PG 1030 11-42T, 11s
MOTOR	Mahle-Ebikemotion X-35
BATTERY	Mahle-Ebikemotion Internal 250Wh
DISPLAY	Mahle-Ebikemotion
DERAILLEUR HANGER	Mondraker M073
OTHERS	---
WEIGHT	---



e-KIDS

PLAY 24

Gloss Black / Racing Silver / Flame Red

FRAME	Play 24 6061 Alloy Stealth evo, hydroformed tubing, integrated internal non-removable battery, Tapered head tube, HHG internal cable routing, BSA bottom bracket, QR 9mm rear axle, 1x drivetrain compatible
SIZES	One size: 320mm
REAR SHOCK	---
SHOCK SETTINGS	---
FORK	RockShox Judy Silver TK 26, 100mm, TurnKey, Solo Air, tapered steerer tube, 9x100mm axle, 30mm steel stanchions, 40mm offset. Settings: compression adjustment at low-speed to lock, rebound, air preload
HEADSET	Onoff Saturn tapered for 1-1/8" to 1-1/2" head tube, ACB sealed bearings, top 41x30.2x7x45°x45°, bottom 51.9x40x8x45°x45°
STEM	Onoff Sulfur FG 30mm 0°, 6061 forged alloy, 31.8mm barbore
HANDLEBAR	MDK XC 1.0, 6061 alloy, rise: 25mm, width: 580mm, 9° backsweep, 5° upsweep, 31.8mm barbore
GRIPS	Onoff Twin, 1lock-on, 135mm
SEATPOST	MDK XC 0-R, 6061 T6 Alloy, diameter 31.6mm, length 300mm
SADDLE	SDG Fly JR
FRONT BRAKE	Sram Level, 2 piece caliper, Centerline 160mm IS 6 bolts one-piece rotor, steel-backed organic pad
REAR BRAKE	Sram Level, 2 piece caliper, Centerline 160mm IS 6 bolts one-piece rotor, steel-backed organic pad
BRAKE LEVER	Sram Level, tooled reach adjust, lever pivot bushings
RIMS	MDK-XP1 24 TLR, 23mm internal width, tubeless ready, 32 spokes
SPOKES	CN round stainless steel
FRONT HUB	Formula DC20LW, 9x100mm, cup & cone ball bearings, IS 6 bolts
REAR HUB	Mahle-Ebikemotion X-35

FRONT TIRE	Kenda Booster 24x2.4 single compound 30TPI, wire bead
REAR TIRE	Kenda Booster 24x2.4 single compound 30TPI, wire bead
CRANKSET	Prowheel, Direct mount chain ring, 127mm
RINGS	28T, steel
BOTTOM BRACKET	Samox BSA, 73mm
PEDALS	---
CHAIN	Sram PC1110 11s, Powerlock
FRONT DERRAILLEUR	---
REAR DERRAILLEUR	Sram NX, 11s, long cage, X-actuation 1:1
SHIFT LEVERS	Sram trigger NX 11s, X-actuation 1:1
CASSETTE	Sram PG 1030 11-42T, 11s
MOTOR	Mahle-Ebikemotion X-35
BATTERY	Mahle-Ebikemotion Internal 250Wh
DISPLAY	Mahle-Ebikemotion
DERAILLEUR HANGER	Mondraker M073
OTHERS	---
WEIGHT	---



e-KIDS

PLAY 20

Gloss Black / Marlin Blue

FRAME	Play 20 6061 Alloy Stealth evo, hydroformed tubing, integrated internal non-removable battery, Tapered head tube, HHG internal cable routing, BSA bottom bracket, QR 9mm rear axle, 1x drivetrain compatible
SIZES	One size: 260mm
REAR SHOCK	---
SHOCK SETTINGS	---
FORK	MDK 20 Kid, Rigid alloy Stealth stanchions, Post Mount disc brake mount
HEADSET	Onoff Saturn tapered for 1-1/8" to 1-1/2" head tube, ACB sealed bearings, top 41x30.2x7x45°x45°, bottom 51.9x40x8x45°x45°
STEM	Onoff Sulfur FG 30mm 0°, 6061 forged alloy, 31.8mm barbore
HANDLEBAR	MDK XC 1.0, 6061 alloy, rise: 25mm, width: 580mm, 9° backsweep, 5° upsweep, 31.8mm barbore
GRIPS	Kids
SEATPOST	MDK XC 0-R, 6061 T6 Alloy, diameter 31.6mm, length 250mm
SADDLE	SDG Fly JR
FRONT BRAKE	Sram Level, 2 piece caliper, Centerline 160mm IS 6 bolts one-piece rotor, steel-backed organic pad
REAR BRAKE	Sram Level, 2 piece caliper, Centerline 160mm IS 6 bolts one-piece rotor, steel-backed organic pad
BRAKE LEVER	Sram Level, tooled reach adjust, lever pivot bushings
RIMS	MDK-XP1 20 TLR, 25mm internal width, tubeless ready, 32 spokes
SPOKES	CN round stainless steel
FRONT HUB	Formula DC20LW, 9x100mm, cup & cone ball bearings, IS 6 bolts
REAR HUB	Mahle-Ebikemotion X-35

FRONT TIRE	Kenda Booster 20x2.4 single compound 30TPI, wire bead
REAR TIRE	Kenda Booster 20x2.4 single compound 30TPI, wire bead
CRANKSET	Prowheel, Direct mount chain ring, 114mm
RINGS	28T, steel
BOTTOM BRACKET	Samox BSA, 73mm
PEDALS	---
CHAIN	Sram PC951 9s, Powerlock
FRONT DERRAILLEUR	---
REAR DERRAILLEUR	Microshift M26S, 9s, short cage
SHIFT LEVERS	Microshift Mezzo TS39-9, 9s
CASSETTE	Microshift Mezzo 11-34T, 9s
MOTOR	Mahle-Ebikemotion X-35
BATTERY	Mahle-Ebikemotion Internal 250Wh
DISPLAY	Mahle-Ebikemotion
DERAILLEUR HANGER	Mondraker M073
OTHERS	---
WEIGHT	---



e-KIDS

GROMMY 16

Color 1: Matte Black / Light Blue / Flame Red - Color 2: Gloss Racing Silver / Black / Flame Red

FRAME	Grommy 16 6061 Alloy Stealth evo, HHG internal cable routing, Resin footrest, Resin motor cover, Resin chain protector, Post mount disc brake mount.
SIZES	One size: 250mm
REAR SHOCK	---
SHOCK SETTINGS	---
FORK	MDK 16 Kid, Rigid alloy Stealth stanchions, Post Mount disc brake mount
HEADSET	FPD CHEX-1089, Internal ZS, 44/50 upper and lower cup
STEM	MDK, 6061 melt forged alloy, 25.4mm barbare, rise: 0°, length: 30mm
HANDLEBAR	MDK 1.0, 6061 alloy, rise: 25mm, width: 500mm, 9° backsweep, 5° upsweep, 25.4mm barbare
GRIPS	Kids
SEATPOST	Pivotal
SADDLE	MDK Kids series
FRONT BRAKE	---
REAR BRAKE	Tektro MD-510 Mechanical hydraulic, flat mount caliper, 140mm IS 6 bolts rotor
BRAKE LEVER	Tektro JL-350RS kids specific alloy 4 fingers
RIMS	MDK-Push 16, alloy 21mm internal width, 28 spokes
SPOKES	CN round stainless steel black
FRONT HUB	KT K88F 9x100mm cup&cone ball bearings 6 bolts
REAR HUB	KT TV-3R 9x110mm cup&cone ball bearings

FRONT TIRE	Vee Tire Crown Gem 16x2.25 27TPI Wired Bead
REAR TIRE	Vee Tire Crown Gem 16x2.25 27TPI Wired Bead
CRANKSET	---
RINGS	10T, steel
BOTTOM BRACKET	---
PEDALS	---
CHAIN	KMC Z33 Half Link, 1 speed.
FRONT DERRAILLEUR	---
REAR DERRAILLEUR	---
SHIFT LEVERS	---
CASSETTE	DNP freewheel 16T
MOTOR	MDK brushless 250w Output
BATTERY	MDK 4Ah 80Wh
DISPLAY	MDK LED Throttle 3speed position, battery range.
DERAILLEUR HANGER	---
OTHERS	---
WEIGHT	---



e-KIDS

GROMMY 12

Color 1: Matte Black / Light Blue / Flame Red - Color 2: Gloss Racing Silver / Black / Flame Red

FRAME	Grommy 12 6061 Alloy Stealth evo, HHG internal cable routing, Resin footrest, Resin motor cover, Resin chain protector, Post mount disc brake mount.
SIZES	One size: 190mm
REAR SHOCK	---
SHOCK SETTINGS	---
FORK	MDK 12 Kid, Rigid alloy Stealth stanchions.
HEADSET	FPD CHEX-1089, Internal ZS, 44/50 upper and lower cup
STEM	MDK, 6061 melt forged alloy, 25.4mm barbore, rise: 0°, length: 30mm
HANDLEBAR	MDK 1.0, 6061 alloy, rise: 25mm, width: 500mm, 9° backsweep, 5° upsweep, 25.4mm barbore
GRIPS	Kids
SEATPOST	One piece Push
SADDLE	MDK Kids series
FRONT BRAKE	---
REAR BRAKE	Tektro MD-510 Mechanical hydraulic, flat mount caliper, 140mm IS 6 bolts rotor
BRAKE LEVER	Tektro JL-350RS kids specific alloy 4 fingers
RIMS	MDK-Push 12, alloy 21mm internal width, 28 spokes
SPOKES	CN round stainless steel black
FRONT HUB	KT K88F 9x100mm cup&cone ball bearings
REAR HUB	KT TV-3R 9x110mm cup&cone ball bearings

FRONT TIRE	Vee Tire Crown Gem 12x2.25 27TPI Wired Bead
REAR TIRE	Vee Tire Crown Gem 12x2.25 27TPI Wired Bead
CRANKSET	---
RINGS	10T, steel
BOTTOM BRACKET	---
PEDALS	---
CHAIN	KMC Z33 Half Link, 1 speed.
FRONT DERRAILLEUR	---
REAR DERRAILLEUR	---
SHIFT LEVERS	---
CASSETTE	DNP freewheel 16T
MOTOR	MDK brushless 250w Output
BATTERY	MDK 4Ah 80Wh
DISPLAY	MDK LED Throttle 3speed position, battery range.
DERRAILLEUR HANGER	---
OTHERS	---
WEIGHT	---

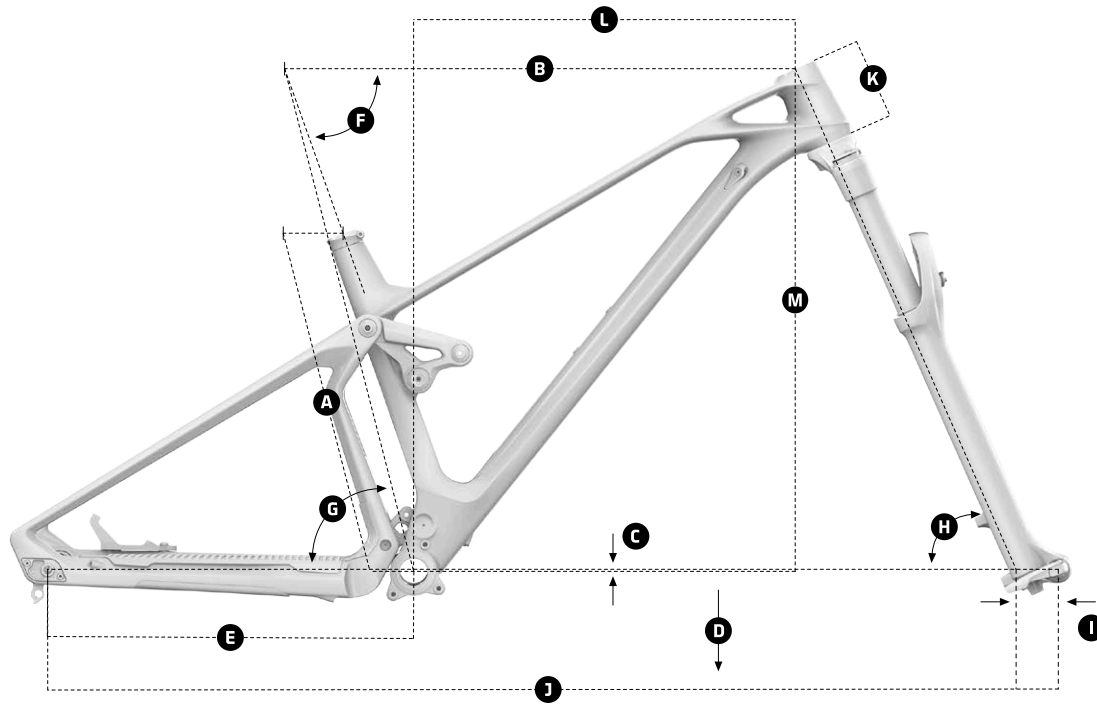

- A** Seat Tube Length
- B** Top Tube Length
- C** Bottom Bracket Drop
- D** Bottom Bracket Height
- E** Chainstay Length
- F** Seat Tube Angle, Actual
- G** Seat Tube Angle, Effective
- H** Head Tube Angle
- I** Fork Offset
- J** Wheelbase
- K** Head Tube Length
- L** Reach
- M** Stack

**DOWNHILL
SUMMUM CARBON**

Size	S	M	L	XL
A Seat Tube Length	400 mm	400 mm	400 mm	400 mm
B Top Tube Length	575 mm	595 mm	620 mm	645 mm
C Bottom Bracket Drop	-20 mm	-20 mm	-20 mm	-20 mm
D Bottom Bracket Height	350 mm	350 mm	350 mm	350 mm
E Chainstay Legth	450/455/460 mm	450/455/460 mm	450/455/460 mm	450/455/460 mm
F Seat Tube Angle, Actual	69°	68,5°	69°	69°
G Seat Tube Angle, Effective	77°	77°	77°	77°
H Head Tube Angle	63°	63,5°	63,5°	63,5°
I Fork Offset	56 mm	56 mm	56 mm	56 mm
J Wheelbase	1260 mm	1270 mm	1295 mm	1320 mm
K Head Tube Length	110 mm	110 mm	112 mm	112 mm
L Reach	430 mm	450 mm	475 mm	500 mm
M Stack	632 mm	633 mm	632 mm	632 mm

**DOWNHILL
SUMMUM**

Size	S	M	L	XL
A Seat Tube Length	400 mm	400 mm	400 mm	400 mm
B Top Tube Length	573 mm	593 mm	618 mm	643 mm
C Bottom Bracket Drop	-20 mm	-20 mm	-20 mm	-20 mm
D Bottom Bracket Height	350 mm	350 mm	350 mm	350 mm
E Chainstay Legth	450 mm	450 mm	450 mm	450 mm
F Seat Tube Angle, Actual	69°	69°	69°	69°
G Seat Tube Angle, Effective	77°	77°	77°	77°
H Head Tube Angle	63°	63,5°	63,5°	63,5°
I Fork Offset	58 mm	58 mm	58 mm	58 mm
J Wheelbase	1260 mm	1270 mm	1295 mm	1320 mm
K Head Tube Length	112 mm	112 mm	112 mm	112 mm
L Reach	430 mm	450 mm	475 mm	500 mm
M Stack	632 mm	632 mm	632 mm	632 mm

**SUPER ENDURO
SUPERFOXY CARBON**

Size	S	M	L	XL
A Seat Tube Length	380 mm	420 mm	470 mm	510 mm
B Top Tube Length	603 mm	626 mm	651 mm	675 mm
C Bottom Bracket Drop	-14 mm	-14 mm	-14 mm	-14 mm
D Bottom Bracket Height	357 mm	357 mm	357 mm	357 mm
E Chainstay Legth	440 - 450 mm	440 - 450 mm	440 - 450 mm	440 - 450 mm
F Seat Tube Angle, Actual	70.5°	70.5°	70.5°	70.5°
G Seat Tube Angle, Effective	75.5°	75.5°	75.5°	75.5°
H Head Tube Angle	65°	65°	65°	65°
I Fork Offset	44 mm	44 mm	44 mm	44 mm
J Wheelbase	1207 mm	1230 mm	1256 mm	1283 mm
K Head Tube Length	90 mm	100 mm	115 mm	130 mm
L Reach	450 mm	470 mm	490 mm	510 mm
M Stack	605 mm	614 mm	628 mm	642 mm

**DOWNHILL
SUMMUM CARBON MX**

Size	S	M	L	XL
A Seat Tube Length	400 mm	400 mm	400 mm	400 mm
B Top Tube Length	577 mm	596 mm	622 mm	647 mm
C Bottom Bracket Drop	0 mm	0 mm	0 mm	0 mm
D Bottom Bracket Height	350 mm	350 mm	350 mm	350 mm
E Chainstay Legth	450/455/460 mm	450/455/460mm	450/455/460 mm	450/455/460 mm
F Seat Tube Angle, Actual	69°	69°	69°	69°
G Seat Tube Angle, Effective	77°	77°	77°	77°
H Head Tube Angle	62,5°	63°	63°	63°
I Fork Offset	56 mm	56 mm	56 mm	56 mm
J Wheelbase	1260 mm	1270 mm	1295 mm	1320 mm
K Head Tube Length	110 mm	110 mm	110 mm	110 mm
L Reach	427 mm	445 mm	470 mm	495 mm
M Stack	633 mm	633 mm	633 mm	633 mm

**DOWNHILL
SUMMUM MX**

Size	S	M	L	XL
A Seat Tube Length	400 mm	400 mm	400 mm	400 mm
B Top Tube Length	576 mm	596 mm	621 mm	646 mm
C Bottom Bracket Drop	15 mm	15 mm	15 mm	15 mm
D Bottom Bracket Height	350 mm	350 mm	350 mm	350 mm
E Chainstay Legth	450 mm	450 mm	450 mm	500 mm
F Seat Tube Angle, Actual	69°	69°	69°	69°
G Seat Tube Angle, Effective	77°	77°	77°	77°
H Head Tube Angle	63,5°	63,5°	63,5°	63,5°
I Fork Offset	58 mm	58 mm	58 mm	58 mm
J Wheelbase	1256 mm	1270 mm	1301 mm	1326 mm
K Head Tube Length	112 mm	112 mm	112 mm	112 mm
L Reach	430 mm	450 mm	475 mm	500 mm
M Stack	632 mm	632 mm	632 mm	632 mm

**SUPER ENDURO
SUPERFOXY**

Size	S	M	L	XL
A Seat Tube Length	380 mm	420 mm	470 mm	510 mm
B Top Tube Length	605 mm	625 mm	650 mm	670 mm
C Bottom Bracket Drop	-20 mm	-20 mm	-20 mm	-20 mm
D Bottom Bracket Height	350 mm	350 mm	350 mm	350 mm
E Chainstay Legth	445 mm	445 mm	445 mm	445 mm
F Seat Tube Angle, Actual	71°	71°	71°	71°
G Seat Tube Angle, Effective	76°	76°	76°	76°
H Head Tube Angle	65°	65°	65°	65°
I Fork Offset	44 mm	44 mm	44 mm	44 mm
J Wheelbase	1224 mm	1245 mm	1273 mm	1293 mm
K Head Tube Length	100 mm	110 mm	130 mm	130 mm
L Reach	450 mm	470 mm	490 mm	510 mm
M Stack	621 mm	621 mm	639 mm	639 mm

**XC RACE
F-PODIUM DC**

Size	S	M	L	XL
A Seat Tube Length	390 mm	420 mm	470 mm	510 mm
B Top Tube Length	583 mm	603 mm	629 mm	654 mm
C Bottom Bracket Drop	-31 mm	-31 mm	-31 mm	-31
D Bottom Bracket Height	337 mm	337 mm	337 mm	337 mm
E Chainstay Legth	432 mm	432 mm	432 mm	432 mm
F Seat Tube Angle, Actual	70.8°	70.8°	70.8°	70.8°
G Seat Tube Angle, Effective	75.1°	75.1°	75.1°	75.1°
H Head Tube Angle	66.8°	66.8°	66.8°	66.8°
I Fork Offset	44 mm	44 mm	44 mm	44 mm
J Wheelbase	1146 mm	1167 mm	1191 mm	1217 mm
K Head Tube Length	85 mm	90 mm	100 mm	115 mm
L Reach	430 mm	450 mm	470 mm	490 mm
M Stack	577 mm	582 mm	591 mm	605 mm

**XC RACE
PODIUM**

Size	S	M	L	XL
A Seat Tube Length	390 mm	420 mm	470 mm	510 mm
B Top Tube Length	590 mm	611mm	632 mm	650 mm
C Bottom Bracket Drop	-65 mm	-65 mm	-65 mm	-65 mm
D Bottom Bracket Height	305 mm	305 mm	305 mm	305 mm
E Chainstay Legth	430 mm	430 mm	430 mm	430 mm
F Seat Tube Angle, Actual	73°	73°	73°	73°
G Seat Tube Angle, Effective	74.5°	74.5°	74.5°	74.5°
H Head Tube Angle	68.5°	68.5°	68.5°	68.5°
I Fork Offset	44 mm	44 mm	44 mm	44 mm
J Wheelbase	1107 mm	1128 mm	1150 mm	1170 mm
K Head Tube Length	85 mm	90 mm	100 mm	115 mm
L Reach	425 mm	444 mm	463 mm	477 mm
M Stack	598 mm	602 mm	611 mm	625 mm

**XC PRO
CHRONO**

Size	S	M	L	XL
A Seat Tube Length	395 mm	430 mm	470 mm	520 mm
B Top Tube Length	590 mm	610 mm	630 mm	650 mm
C Bottom Bracket Drop	-65 mm	-65 mm	-65 mm	-65 mm
D Bottom Bracket Height	305 mm	305 mm	305 mm	305 mm
E Chainstay Legth	435 mm	435 mm	435 mm	435 mm
F Seat Tube Angle, Actual	72.5°	72.5°	72.5°	72.5°
G Seat Tube Angle, Effective	73.5°	73.5°	73.5°	73.5°
H Head Tube Angle	70°	70°	70°	70°
I Fork Offset	44 / 46 mm	44 / 46 mm	44 / 46 mm	44 / 46 mm
J Wheelbase	1087 mm	1107 mm	1127 mm	1148 mm
K Head Tube Length	100 mm	100 mm	110 mm	125 mm
L Reach	406 mm	426 mm	444 mm	460 mm
M Stack	618 mm	618 mm	628 mm	642 mm

**XC RACE
F-PODIUM**

Size	S	M	L	XL
A Seat Tube Length	390 mm	420 mm	470 mm	510 mm
B Top Tube Length	580 mm	600 mm	625 mm	650 mm
C Bottom Bracket Drop	-35	-35	-35	-35
D Bottom Bracket Height	320 mm	320 mm	320 mm	320 mm
E Chainstay Legth	432 mm	432 mm	432 mm	432 mm
F Seat Tube Angle, Actual	71.3°	71.3°	71.3°	71.3°
G Seat Tube Angle, Effective	75.8°	75.8°	75.8°	75.8°
H Head Tube Angle	67.3°	67.3°	67.3°	67.3°
I Fork Offset	44 mm	44 mm	44 mm	44 mm
J Wheelbase	1138 mm	1159 mm	1183 mm	1209 mm
K Head Tube Length	85 mm	90 mm	100 mm	115 mm
L Reach	437 mm	453 mm	473 mm	493 mm
M Stack	570 mm	575 mm	584 mm	598 mm

**XC PRO
CHRONO CARBON**

Size	S	M	L	XL
A Seat Tube Length	395 mm	430 mm	470 mm	520 mm
B Top Tube Length	590 mm	610 mm	630 mm	650 mm
C Bottom Bracket Drop	-65 mm	-65 mm	-65 mm	-65 mm
D Bottom Bracket Height	305 mm	305 mm	305 mm	305 mm
E Chainstay Legth	430 mm	430 mm	430 mm	430 mm
F Seat Tube Angle, Actual	72°	72°	72°	72°
G Seat Tube Angle, Effective	73.5°	73.5°	73.5°	73.5°
H Head Tube Angle	70°	70°	70°	70°
I Fork Offset	44 / 51 mm	44 / 51 mm	44 / 51 mm	44 / 51 mm
J Wheelbase	1086 mm	1106 mm	1127 mm	1148 mm
K Head Tube Length	85 mm	90 mm	100 mm	115 mm
L Reach	411 mm	430 mm	447 mm	463 mm
M Stack	605 mm	610 mm	619 mm	632 mm

**e-MTB ENDURO
DUSK**

Size	S	M	L	XL
A Seat Tube Length	380 mm	420 mm	450 mm	490 mm
B Top Tube Length	605 mm	625 mm	650 mm	670 mm
C Bottom Bracket Drop	-25 mm	-25 mm	-25 mm	-25 mm
D Bottom Bracket Height	350 mm	350 mm	350 mm	350 mm
E Chainstay Legth	455 mm	455 mm	455 mm	455 mm
F Seat Tube Angle, Actual	73.5°	73.5°	73.5°	73.5°
G Seat Tube Angle, Effective	76°	76°	76°	76°
H Head Tube Angle	65.5°	65.5°	65.5°	65.5°
I Fork Offset	44 mm	44 mm	44 mm	44 mm
J Wheelbase	1225 mm	1245 mm	1265 mm	1285 mm
K Head Tube Length	110 mm	110 mm	130 mm	130 mm
L Reach	450 mm	470 mm	490 mm	510 mm
M Stack	622 mm	622 mm	640 mm	640 mm

**e-MTB TRAIL
PRIME 29**

Size	XS	S	M	L	XL
A Seat Tube Length	380 mm	390 mm	430 mm	470 mm	510 mm
B Top Tube Length	600 mm	615 mm	645 mm	670 mm	700 mm
C Bottom Bracket Drop	-60 mm	-60 mm	-60 mm	-60 mm	-60 mm
D Bottom Bracket Height	318 mm	318 mm	318 mm	318 mm	318 mm
E Chainstay Legth	455 mm	455 mm	455 mm	455 mm	455 mm
F Seat Tube Angle, Actual	73.5°	73.5°	73.5°	73.5°	73.5°
G Seat Tube Angle, Effective	73.5°	73.5°	73.5°	73.5°	73.5°
H Head Tube Angle	69°	69°	69°	69°	69°
I Fork Offset	51 mm	51 mm	51 mm	51 mm	51 mm
J Wheelbase	1138mm	1153 mm	1183 mm	1210 mm	1240 mm
K Head Tube Length	110 mm	110 mm	110 mm	130 mm	130 mm
L Reach	410 mm	425 mm	455 mm	480 mm	505 mm
M Stack	640 mm	640 mm	640 mm	658 mm	658 mm

**e-MTB TRAIL
PRIME X**

Size	XS	S	M	L	XL
A Seat Tube Length	380 mm	390 mm	430 mm	470 mm	510 mm
B Top Tube Length	600 mm	615 mm	645 mm	670 mm	700 mm
C Bottom Bracket Drop	-70 mm	-70 mm	-70 mm	-70 mm	-70 mm
D Bottom Bracket Height	308 mm	308 mm	308 mm	308 mm	308 mm
E Chainstay Legth	455 mm	455 mm	455 mm	455 mm	455 mm
F Seat Tube Angle, Actual	74.5°	74.5°	74.5°	74.5°	74.5°
G Seat Tube Angle, Effective	74.5°	74.5°	74.5°	74.5°	74.5°
H Head Tube Angle	70°	70°	70°	70°	70°
I Fork Offset	51 mm	51 mm	51 mm	51 mm	51 mm
J Wheelbase	1132 mm	1148 mm	1178 mm	1205 mm	1235 mm
K Head Tube Length	110 mm	110 mm	110 mm	130 mm	130 mm
L Reach	415 mm	430 mm	460 mm	485 mm	510 mm
M Stack	630 mm	630 mm	630 mm	648 mm	648 mm

**KIDS
FACTOR 26 / 24**

Size	26	24
A Seat Tube Length	350mm	320 mm
B Top Tube Length	550mm	510 mm
C Bottom Bracket Drop	-10 mm	-10 mm
D Bottom Bracket Height	320 mm	295 mm
E Chainstay Legth	420 mm	420 mm
F Seat Tube Angle, Actual	71°	71°
G Seat Tube Angle, Effective	76°	76°
H Head Tube Angle	67°	67°
I Fork Offset	41 mm	41 mm
J Wheelbase	1105 mm	1064 mm
K Head Tube Length	90 mm	90 mm
L Reach	415 mm	375 mm
M Stack	545 mm	513 mm

**e-MTB TRAIL
PRIME +**

Size	XS	S	M	L	XL
A Seat Tube Length	380 mm	390 mm	430 mm	470 mm	510 mm
B Top Tube Length	600 mm	615 mm	645 mm	670 mm	700 mm
C Bottom Bracket Drop	-60 mm	-60 mm	-60 mm	-60 mm	-60 mm
D Bottom Bracket Height	305 mm	305 mm	305 mm	305 mm	305 mm
E Chainstay Legth	455 mm	455 mm	455 mm	455 mm	455 mm
F Seat Tube Angle, Actual	73.5°	73.5°	73.5°	73.5°	73.5°
G Seat Tube Angle, Effective	73.5°	73.5°	73.5°	73.5°	73.5°
H Head Tube Angle	69°	69°	69°	69°	69°
I Fork Offset	51 mm	51 mm	51 mm	51 mm	51 mm
J Wheelbase	1138 mm	1153 mm	1183 mm	1210 mm	1240 mm
K Head Tube Length	110 mm	110 mm	110 mm	130 mm	130 mm
L Reach	410 mm	425 mm	455 mm	480 mm	505 mm
M Stack	640 mm	640 mm	640 mm	658 mm	658 mm

**e-MTB TRAIL
THUNDRA / THUNDRA X**

Size	XS	S	M	L	XL
A Seat Tube Length	380 mm	390 mm	430 mm	470 mm	510 mm
B Top Tube Length	600 mm	615 mm	645 mm	670 mm	700 mm
C Bottom Bracket Drop	-60 mm	-60 mm	-60 mm	-60 mm	-60 mm
D Bottom Bracket Height	317 mm	317 mm	317 mm	317 mm	317 mm
E Chainstay Legth	455 mm	455 mm	455 mm	455 mm	455 mm
F Seat Tube Angle, Actual	73.5°	73.5°	73.5°	73.5°	73.5°
G Seat Tube Angle, Effective	73.5°	73.5°	73.5°	73.5°	73.5°
H Head Tube Angle	69°	69°	69°	69°	69°
I Fork Offset	51 mm	51 mm	51 mm	51 mm	51 mm
J Wheelbase	1138mm	1153 mm	1183 mm	1210 mm	1240 mm
K Head Tube Length	110 mm	110 mm	110 mm	130 mm	130 mm
L Reach	410 mm	425 mm	455 mm	480 mm	505 mm
M Stack	640 mm	640 mm	640 mm	658 mm	658 mm

**KIDS
LEADER 26 / 24 / 20 / 16**

Size	26	24	20	16
A Seat Tube Length	350mm	320 mm	260 mm	215 mm
B Top Tube Length	565mm	510 mm	440 mm	395 mm
C Bottom Bracket Drop	-30mm	-30 mm	-15 mm	-10 mm
D Bottom Bracket Height	285 mm	280 mm	240 mm	190 mm
E Chainstay Legth	420 mm	395 mm	350 mm	310 mm
F Seat Tube Angle, Actual	71°	71°	71°	69°
G Seat Tube Angle, Effective	71°	71°	71°	69°
H Head Tube Angle	68°	68°	68°	69°
I Fork Offset	40 mm	40 mm	45 mm	30 mm
J Wheelbase	1050 mm	964 mm	855 mm	733 mm
K Head Tube Length	100 mm	100 mm	100 mm	100 mm
L Reach	377 mm	340 mm	307 mm	265 mm
M Stack	553 mm	493 mm	386 mm	338 mm



e-KIDS

F-PLAY 26 / 24

Size	26	24
A Seat Tube Length	350 mm	320 mm
B Top Tube Length	550 mm	525 mm
C Bottom Bracket Drop	-10 mm	-10 mm
D Bottom Bracket Height	320 mm	295 mm
E Chainstay Legth	420 mm	420 mm
F Seat Tube Angle, Actual	71°	71°
G Seat Tube Angle, Effective	76°	76°
H Head Tube Angle	67°	67°
I Fork Offset	41 mm	40 mm
J Wheelbase	1104 mm	1050 mm
K Head Tube Length	90 mm	90 mm
L Reach	415 mm	375 mm
M Stack	545 mm	513 mm

e-KIDS

GROMMY 16 / 12

Size	16	12
A Seat Tube Length	215 mm	155 mm
B Top Tube Length	465 mm	400 mm
C Bottom Bracket Drop	---	---
D Bottom Bracket Height	180 mm	150 mm
E Chainstay Legth	340 mm	285 mm
F Seat Tube Angle, Actual	---	---
G Seat Tube Angle, Effective	---	---
H Head Tube Angle	---	---
I Fork Offset	---	---
J Wheelbase	810 mm	695 mm
K Head Tube Length	---	---
L Reach	---	---
M Stack	400 mm	345 mm

e-KIDS

PLAY 26 / 24 / 20

Size	26	24	20
A Seat Tube Length	350 mm	320 mm	260 mm
B Top Tube Length	567 mm	517 mm	475 mm
C Bottom Bracket Drop	-30 mm	-30 mm	-15 mm
D Bottom Bracket Height	300 mm	280 mm	240 mm
E Chainstay Legth	420 mm	405 mm	355 mm
F Seat Tube Angle, Actual	72°	72°	72°
G Seat Tube Angle, Effective	72°	72°	72°
H Head Tube Angle	68°	68°	68°
I Fork Offset	40 mm	40 mm	40 mm
J Wheelbase	1060 mm	994 mm	903 mm
K Head Tube Length	100 mm	100 mm	100 mm
L Reach	390 mm	350 mm	340 mm
M Stack	546 mm	537 mm	387 mm



All information and pictures on this document is provided for information purposes only and does not constitute a legal contract between Mondraker and any person or entity. Specifications, geometries or any other technical information published is subject to change without prior notice.

© All trademarks and models are property of Blue Factory Team, S.L.U. and are protected by current laws and applicable international agreements.



T H A N K Y O U