

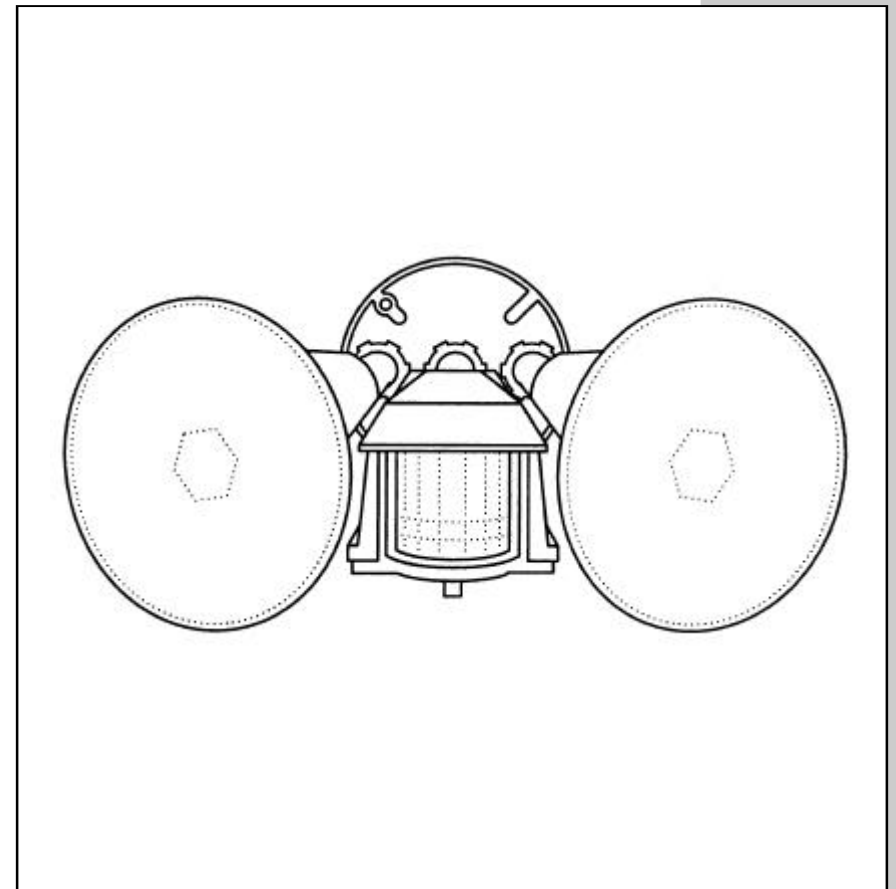

Floodlight Motion Detector

Installer's Guide



Floodlight Motion Detector PHS01

Installation

Locating the Motion Detector

The Motion Detector mounting plate is designed to fit a standard round outdoor electrical junction box (not included).

The detector should be mounted around 6-8ft above the ground in a location so that a moving object will cut across its beams.

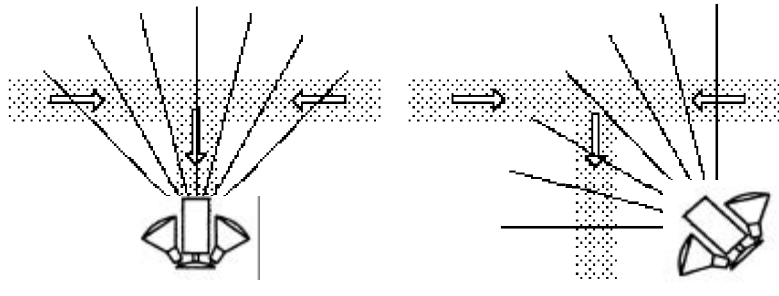

*Poor location
(movement directly
toward sensor may
not be detected)*

*Good location
(movement on any path
will cross sensor
beams and be
detected)*

Consider the following points when locating the sensor:

- The Motion Detector must be at least 6-8ft above the ground and be parallel to the ground.
- Existing floodlights must be aimed away from the sensor.
- Direct sunlight must not fall on the sensor lens.
- The sensor must not face reflective surfaces such as a swimming pool or large windows.
- You must not mount the sensor over heat producing vents or air conditioning units.
- The sensor cannot 'see' through glass.

Note: The sensor 'sees' a moving object by detecting a change in temperature. If you install and set up the Motion Detector on a very hot day, it will be difficult for the sensor to detect the difference between the heat from your body and the background temperature. (At 98.6°F you are invisible to the sensor). In very hot weather it is recommended that you make test adjustments in the evening when it is cooler.

Installation

Installing the Motion Detector

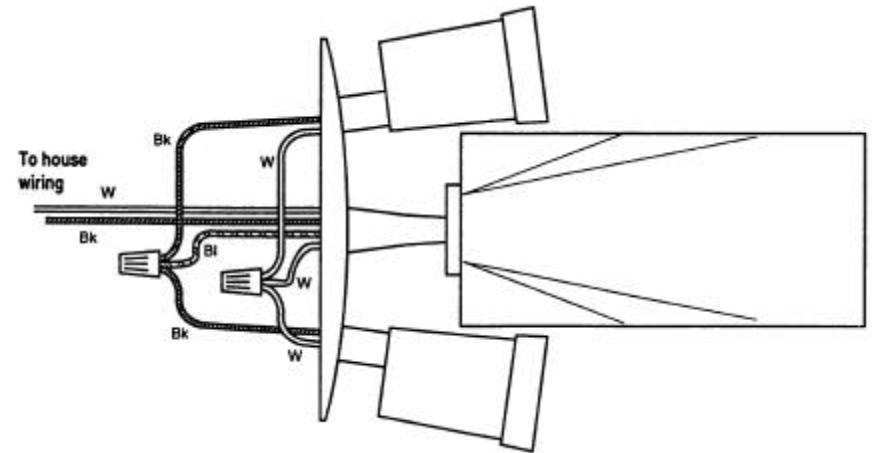

- Screw the base of each lamp holder into the outer holes of the mounting plate and secure them with the locking rings.
- Screw the sensor head into the center hole of the mounting plate and lock it into place with the locking ring.
- Connect the white wire from each of the lamp holders to one of the white wires from the sensor head using one of the wire nuts provided.
- Connect the black wire from each of the lamp holders to the blue wire from the sensor head using one of the wire nuts provided.
- Install the supplied gasket on the junction box and route the house wiring through the gasket.
- Connect the black wire and the remaining white wire from the sensor head to the house wiring. Black to Live and White to Neutral. Do not connect the Black to a switched Live as from a wall switch. The PHS01 requires uninterrupted power at all times.
- Screw the motion sensor to the wall box and align the sensor head and floodlights as desired.

Note: The Motion Detector has a special lens that 'looks' downwards. It must therefore be mounted to face outwards horizontally, i.e. do not 'aim' the sensor downwards.

Controls and Settings

Control Panel

The control switches for the Motion Detector are located underneath the sensor head. Open the control panel cover by turning the knurled screw.

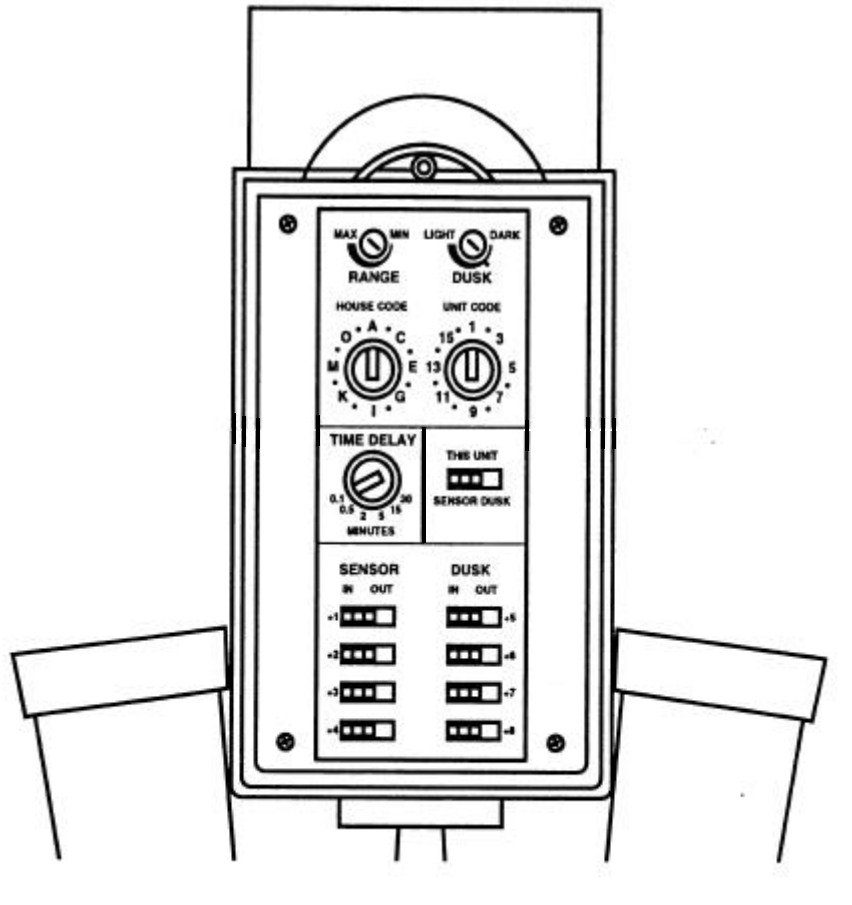

Controls and Settings

Adjusting the Motion Detector Sensor Coverage

- Set the DUSK control fully clockwise to LIGHT.
- Set the RANGE control fully clockwise to MAX.
- Set the TIME DELAY to 0.1 minutes (approx. 6 seconds) using a flathead screwdriver.
- Swivel the sensor head toward the area you want to cover. Be sure the sensor head remains level from side-to-side and level with the ground.
- Aim the floodlights at the area you wish to light.
- Turn on the power and wait for one minute.
- Walk around the covered area. Whenever the sensor 'sees' you the floodlights come on and remain on for six seconds after you stop moving. If necessary, reorient the sensor head so normal road traffic does not activate the Motion Detector.

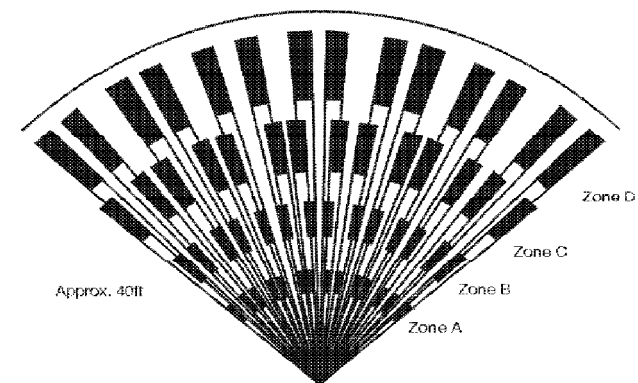
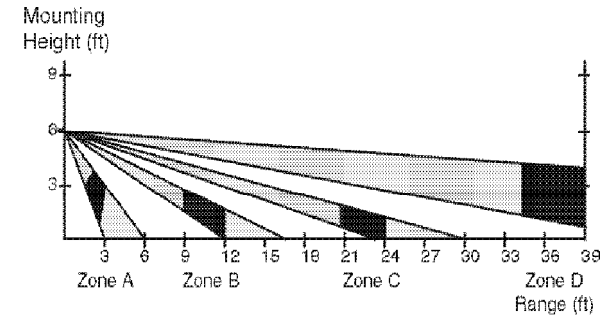

Controls and Settings

Dusk control



The default setting for the dusk control is indicated by the index mark. This setting should be tried before making any further adjustments. The setting of the dusk control is quite sensitive, so only make small adjustments each time.

Note: When you change the setting of this control, or when the light level changes, the new setting does not take effect until 10 minutes after the setting was changed or the light level changed. If movement is detected just after an adjustment was made, you will need to wait until 10 minutes after the delay time you set on the Motion Detector.

- Turn the control toward DARK if the Motion Detector comes on too early.
- Turn the control toward LIGHT if the Motion Detector comes on too late.
- Turn the control all the way to LIGHT to activate the Motion Detector all the time.

Range control

- Turn towards MAX to increase range.
- Turn towards MIN to avoid traffic, pets or small animals triggering the Motion Detector.

Time Delay switch

- Set to desired time for lights to stay on when no further motion has been detected.

This Unit switch

- Set to SENSOR to have floodlights turn on when motion is detected.
- Set to DUSK to have floodlights turn on at dusk and off at dawn.

House Code

- Set the House Code to match other X-10 modules which are to be controlled by the Motion Detector.

Start Code

- This is the House Code for the Motion Detector. The Motion Detector floodlights can be switched on and off from an X-10 controller using the same House Code and Unit Code.

The Start Code is also the number which is added to the slide switch numbers to set the Unit Codes for other modules controlled by the Motion Detector.

Note: When the floodlights are switched on using an X-10 controller, they will stay on until they are turned off again using an X-10 controller.

Controls and Settings

Sensor switches

- These switches determine which other modules will be switched on when motion is sensed. The number next to the switch (+1 to +4) is added to the Start Code to determine the Unit Code for a module. (For example, if the Start Code is set to 3 and the Sensor Switch labelled '2' is set to 'IN', the module with unit code 5 and the same House Code as the Motion Detector will switch on).

i.e. Start code (3) plus In/Out switch (+2) = 5. Set the module inside the house (having the same House Code) to unit 5 and when motion is detected after dark, the module unit 5 will also cycle with the floodlights.

Dusk switches

- These switches determine which other modules will be switched on at dusk and off at dawn. The number next to the switch (+5 to +8) is added to the Start Code to determine the Unit Code for a module. (For example, if the Start Code is set to 3 and the Sensor Switch labelled '6' is set to 'IN', the module with unit code 9 and the same House Code as the Motion Detector will switch on).

Example: see above sample, changing values for +5 through +8.

Caution: To avoid the risk of fire or injury ensure that potentially hazardous appliances such as portable heaters or fans will not be accidentally controlled by the Motion Detector. Choose controlled Unit Codes carefully.

Troubleshooting

Problem: The floodlights are on constantly and will not shut off.

Solution: Make sure that the power supplied to the PHS01 is un-interrupted as with a wall switch. Rewire the Power to maintain constant power, then send an Off command to the PHS01 from an X-10 PRO controller, (such as the PHC01 Mini Controller), returning the PHS01 to cycling.

Also, a flood light accidentally powered off during a time delay will stay locked on. After dark, (see position of light/dark setting) trigger the sensor by a motion, after the delay time they will return to normal cycling.

Problem: I want to have the lights on for a couple hours for a party, what do I do?

Solution: Once again, using the X-10 PRO PHC01 Mini Controller, you can send an ON command to the PHS01 start code, and it will stay on until an Off command is sent.

Problem: I have an X-10 PRO wall switch inside the house that is set to match one of the Sensor switches (+1 to +4) on the PHS01 and some times it does not respond to the command sent by the PHS01.

Solution: You may have crossed over the electrical phase of the breaker panel to the opposite side. Install an XPCP Passive Coupler in the breaker panel to solve this. Another possibility is the occurrence of electrical noise on the power line generated by an electronic device plugged into the power of the house. An X-10 PRO XPPF Plug-in Filter will isolate the noise from the offending device. Plug the offending device into the Filter and plug the Filter into the power outlet.

