

# Hotel Source Book

A Hotelier's Guide to quality  
Guest Room Supplies & Equipment.



Explore an abundance of innovative, long-lasting and environmentally sustainable touch-points that bring your property's guest experience to life.



Who we are



## The World of Swisstrade

Welcome to the world of Swisstrade, where our guest experience professionals and distribution partners bring hospitality expertise and real hotel brands together.

Since 1997, we pursue a vision of providing hoteliers with access to international standards in hotel toiletries and operating equipment for the guest room.

As a proud Australian company, we pioneered environmentally sustainable amenities dispenser systems during the 2000 Sydney 'Green Olympics' and have since perfected our low-waste, eco-conscious solutions even further. Combined with our hotel-specific guest room equipment and appliances, our collections of class-leading toiletries meet the budgets and expectations of our accommodation providers locally and nationwide.

Together, we can deliver sustainable value on investment for owners, operators and their guests alike.

**That's our hospitality, that's Swisstrade...**  
**At your advantage.**



# Contents

1. Amenities Dispensers	5
2. Hotel Cosmetics   Value Collection	15
3. Hotel Cosmetics   Boutique Collection	22
4. Bathroom Accessories	27
5. Guest Room Equipment	32
6. Bathroom Fixtures & Accessories	73
7. Guest Room Accessories	81
8. Lobby & Housekeeping	90
9. Hotel Project Services	94
10. Contact	95

## Icon Key



Great Value



Priced to Clear



Environmental



Best Seller



Energy Efficient



Free Trial



Covid Safe



New Product



Special Order



**Amenities Dispensers | SHAPE**



# SHAPE

THE SUSTAINABLE HYGIENIC & AESTHETIC PUMP EVOLUTION.



Engineered for precise, effortless operation, a simple press of the finger dispenses the exact amount of formulation. A secure pump lock prevents germs from entering the cartridge, creating peace of mind for the hotelier and maximum hygiene for the guest.



**Fair CosmEthics - Shampoo Hair & Body 300ml**  
FT-SPBS300, ctn qty 30  
Featuring Fairtrade certified cane sugar, Brazil nut oil & olive oil



**Fair CosmEthics - Conditioner 300ml**  
FT-SPCO300, ctn qty 30  
Featuring Fairtrade certified cane sugar, Brazil nut oil & olive oil



**Fair CosmEthics - Liquid Cream Soap 300ml**  
FT-SPLS300, ctn qty 30  
Featuring Fairtrade certified cane sugar, Brazil nut oil & olive oil



**Fair CosmEthics - Shampoo 300ml**  
FT-SPHS300, ctn qty 30  
Featuring Fairtrade certified cane sugar, Brazil nut oil & olive oil



**Fair CosmEthics - Hand & Body Lotion 300ml**  
FT-SPBL300, ctn qty 30  
Featuring Fairtrade certified cane sugar, Brazil nut oil & olive oil



**Fair CosmEthics - Body Cleanser 300ml**  
FT-SPDG300, ctn qty 30  
Featuring Fairtrade certified cane sugar, Brazil nut oil & olive oil



**The Perfumers' Garden - Hand & Body Wash 300ml**  
PG-SPHBW300, ctn qty 30  
Infused with scents of exquisite green tea & ginger



**The Perfumers' Garden - Liquid Soap 300ml**  
PG-SPLS300, ctn qty 30  
Infused with scents of exquisite green tea & ginger



**The Perfumers' Garden - Shampoo Hair & Body 300ml**  
PG-SPBS300, ctn qty 30  
Infused with scents of exquisite green tea & ginger



**The Perfumers' Garden - Conditioning Shampoo 300ml**  
PG-SPCS300, ctn qty 30  
Infused with scents of exquisite green tea & ginger



**The Perfumers' Garden - Hand & Body Lotion 300ml**  
PG-SPHBL300, ctn qty 30  
Infused with scents of exquisite green tea & ginger



**Single Wall Holder, Self-Adhesive - White**  
SMHA110, ctn qty 10  
Pilfer and tamper proof



**Single Wall Holder, Self-Adhesive - Chrome**  
SMHA111, ctn qty 10  
Pilfer and tamper proof



**Single Wall Holder, Self-Adhesive - Black**  
SMHA115, ctn qty 10  
Pilfer and tamper proof



**Single Wall Holder, Screw-On - White**  
SMHA010, ctn qty 10  
Pilfer and tamper proof



**Single Wall Holder, Screw-On - Chrome**  
SMHA011, ctn qty 10  
Pilfer and tamper proof



**Amenities Dispensers** | Smart Care





## Smart Care

THE ENVIRONMENTALLY FRIENDLY, SLIM-LINE AMENITY DISPENSER SYSTEM.



Discover Swisstrade's attractive and cost-efficient SmartCare System, the future of factory sealed and tamper-proof bathroom dispensers. Choose from a comprehensive range of high-quality brands to match your property style.



**Bio Naturals - Shampoo Hair & Body 300ml**  
NA-SMBS300, ctn qty 30  
Certified organic citrus extracts  
dark green dispenser



**Bio Naturals - Conditioner 300ml**  
NA-SMCO300, ctn qty 30  
Certified organic citrus extracts  
dark green dispenser



**Bio Naturals - Liquid Cream Soap 300ml**  
NA-SMLS300, ctn qty 30  
Certified organic citrus extracts  
dark green dispenser



**Bio Naturals - Shampoo 300ml**  
NA-SMHS300, ctn qty 30  
Certified organic citrus extracts  
dark green dispenser



**NATURALS Remedies - Liquid Cream Soap 300ml**  
NR-SMLS300, ctn qty 30  
Organic sage, currant and nettle  
matt black dispenser



**NATURALS Remedies - Body Lotion 300ml**  
NR-SMBLS300, ctn qty 30  
Organic sage, currant and nettle  
matt black dispenser



**NATURALS Remedies - Hand & Body Wash 300ml**  
NR-SMHBW300, ctn qty 30  
Organic sage, currant and nettle  
matt black dispenser



**NATURALS Remedies - Shampoo with Conditioner 300ml**  
NR-SMCS300, ctn qty 30  
Organic sage, currant and nettle  
matt black dispenser



**ECO by Green Culture -  
Liquid Cream Soap 300ml**  
ECO-SMLS300, ctn qty 30  
Ecologically certified formulation  
vibrant green dispenser



**ECO by Green Culture -  
Refreshing Shower Gel 300ml**  
ECO-SMDG300, ctn qty 30  
Ecologically certified formulation  
vibrant green dispenser



**ECO by Green Culture -  
Shampoo 300ml**  
ECO-SMHS300, ctn qty 30  
Ecologically certified formulation  
vibrant green dispenser



**ECO by Green Culture -  
Shampoo Hair & Body Wash 300ml**  
ECO-SMBS300, ctn qty 30  
Ecologically certified formulation  
vibrant green dispenser



**Pure Herbs -  
Liquid Cream Soap 300ml**  
PH-SMLS300, ctn qty 30  
Aromatic Alpine herbal extracts  
green dispenser



**Pure Herbs -  
Refreshing Shower Gel 300ml**  
PH-SMDG300, ctn qty 30  
Aromatic Alpine herbal extracts  
green dispenser



**Pure Herbs -  
Shampoo with Conditioner 300ml**  
PH-SMCS300, ctn qty 30  
Aromatic Alpine herbal extracts  
green dispenser



**BE Different - All-In-One Shampoo  
Hair & Body Wash 300ml**  
BD-SMAIO300, ctn qty 30  
Watermelon, berry, lime & mint



**Hydro Basics -  
Liquid Cream Soap 300ml**  
HY-SMLS300, ctn qty 30  
Patchouli, cedar, lily & jasmine  
light blue dispenser



**Hydro Basics -  
Refreshing Shower Gel 300ml**  
HY-SMDG300, ctn qty 30  
Patchouli, cedar, lily & jasmine  
light blue dispenser



**Hydro Basics -  
Shampoo Hair & Body 300ml**  
HY-SMBS300, ctn qty 30  
Patchouli, cedar, lily & jasmine  
light blue dispenser



**Hydro Basics -  
Shampoo with Conditioner 300ml**  
HY-SMCS300, ctn qty 30  
Patchouli, cedar, lily & jasmine  
light blue dispenser



**Bogner -  
Liquid Cream Soap 300ml**  
BO-SMLS300, ctn qty 30  
Orange, jasmine, rose and musk  
silver dispenser



**Bogner -  
Shampoo Hair & Body 300ml**  
BO-SMBS300, ctn qty 30  
Orange, jasmine, rose and musk  
silver dispenser



**Wall Holder -  
single white, adhesive**  
SMHA110, ctn qty 10



**Wall Holder -  
single white, screw on**  
SMHA010, ctn qty 10



**Wall Holder -  
single chrome, adhesive**  
SMHA111, ctn qty 10



**Wall Holder -  
single chrome, screw on**  
SMHA011, ctn qty 10



**Wall Holder - double white,  
screw on & adhesive**  
SMHD210, ctn qty 10



**Wall Holder - double chrome,  
screw on & adhesive**  
SMHD214, ctn qty 10



**Amenities Dispensers** | Press + Wash



## Hotel Amenities Dispenser System



EUROPE'S LEADING HOTEL DISPENSER SYSTEM

Offer the ultimate in hygiene and safety while pampering your guests with a premium experience. Explore Swisstrade's wide range of cost-effective, sealed Press & Wash Dispensers that suit all styles of hotel. High-quality European formulations and fragrances, and leading environmental, recyclable dispensers make Press & Wash Australia's most popular hotel amenity dispenser.



**Hydro Basics Silver Label - Liquid Cream Soap 300ml**  
HY-PWLS300-148B, ctn qty 30, with seaweed extracts



**Hydro Basics Silver Label - Conditioning Shampoo 300ml**  
HY-PWCS300-148B, ctn qty 30 with seaweed extracts



**Hydro Basics Silver Label - Refreshing Shower Gel 300ml**  
HY-PWDG300-148B, ctn qty 30  
With seaweed extracts



**Hydro Basics Blue Label - Shampoo Hair & Body 300ml**  
HY-PWBS300-148B, ctn qty 30  
With seaweed extracts



**Bogner - Liquid Cream Soap 300ml**  
BO-PWLS300, ctn qty 30  
European Sports & Lifestyle Brand



**Bogner - Conditioning Shampoo 300ml**  
BO-PWBS300, ctn qty 30  
European Sports & Lifestyle Brand



**Bogner - Refreshing Shower Gel, 300ml**  
BO-PWDG300, ctn qty 30  
European Sports & Lifestyle Brand



**BioNaturals - Liquid Cream Soap 330ml**  
NA-COLS330, ctn qty 30  
With certified organic ingredients  
transparent side strip



**BioNaturals - Shampoo Hair & Body 330ml**  
NA-COBS330, ctn qty 30  
With certified organic ingredients  
transparent side strip



**Pure Herbs silver label - Liquid Cream Soap 300ml**  
PH-PWLS300-148, ctn qty 30  
With herbal extracts from Rosemary, Melissa and Thyme



**Pure Herbs silver label - Conditioning Shampoo 300ml**  
PH-PWCS300-148, ctn qty 30  
With herbal extracts from Rosemary, Melissa and Thyme



**Pure Herbs silver label - Refreshing Shower Gel 300ml**  
PH-PWDG300-148, ctn qty 30  
With herbal extracts from Rosemary, Melissa and Thyme



**Pure Herbs - Liquid Cream Soap 300ml**  
PH-PWLS300, ctn qty 30  
With herbal extracts from Rosemary, Melissa and Thyme



**Pure Herbs - Shampoo Hair & Body 300ml**  
PH-PWBS300, ctn qty 30  
With herbal extracts from Rosemary, Melissa and Thyme



**Aqua Senses - Shampoo Hair & Body 330ml**  
AS-COBS330, ctn qty 30  
With herbal extracts from bergamot, white jasmine and sandalwood



**Aqua Senses - Liquid Soap 330ml**  
AS-COLS330, ctn qty 30  
With herbal extracts from bergamot, white jasmine and sandalwood



**Press & Wash Replacement Collar**  
PWHU009, ctn qty 20  
Collar, transparent



**Wall Holder - white, self-adhesive**  
PWAH110, ctn qty 10



**Wall Holder - white, screw-on**  
PWAH010, ctn qty 10  
screws & wall plugs included



**Wall Holder - chrome, self-adhesive**  
PWAH111, ctn qty 10



**Wall Holder - chrome, screw-on**  
PWAH011, ctn qty 10  
screws & wall plugs included



**Hotel Cosmetics** | Value Collection



[ body zone ]

## Body Zone Black Label

With its striking design and luxury ingredients, Body Zone black label Collection is bound to treat your guests with some unexpected moments of self-indulgence. The key ingredient Moroccan Argan Oil is high in Vitamin E, Omega 3 and Antioxidants, working tirelessly to keep skin, hair and body nourished and youthful. Body Zone black label provides an enhanced guest experience and a stand-out design element to your guest bathrooms.



**Hair Shampoo 20ml**  
with Argan Oil & Vitamin E  
BOZ-TUHS020, ctn qty 500



**Hair Conditioner 20ml**  
with Argan Oil & Vitamin E  
BOZ-TUCO020 - ctn qty 500



**Bath & Shower Gel 20ml**  
with Argan Oil & Vitamin E  
BOZ-TUDG020, ctn qty 500



**Body Lotion 20ml**  
with Argan Oil & Vitamin E  
BOZ-TUBL020, ctn qty 500



**Vegetable Soap 20g**  
BOZ-TUBL020, ctn qty 500



**Vegetable Soap 40g**  
BOZ-SOAP040, ctn qty 300



**Amenity Set, small**  
BUE-AMSE222, ctn qty 500  
incl. Shower Cap & Sanitary Bag



**Amenity Set, large**  
BUE-AMSE333, ctn qty 500  
incl. Shower Cap, Sanitary Bag,  
Vanity Set w. Nail File & Sewing Kit



**Shaving Set**  
BUE-SHKI022, ctn qty 250  
incl. Schick Razor & Shaving Cream



**Dental Set - open**  
BUE-DEKI022, ctn qty 250  
incl. Travel Toothbrush &  
Colgate Toothpaste



**Tray with bevelled edges**  
BOZ-APTC000, ctn qty 50  
Acrylic Presentation Tray clear, with  
bevelled edges and Body Zone logo  
(270 x 110 x 10mm)





## Natural Evolution

Designed to address environmental awareness in the hospitality industry and to cater for today's eco conscious hotel guests, these products are the ideal solution for environmentally responsible hotels, motels and eco aware resorts.



**Shampoo 20ml**  
NEV-TUHS020, ctn qty 500  
Biodegradable plastic tubes & caps



**Conditioner 20ml**  
NEV-TUCO020, ctn qty 500  
Biodegradable plastic tubes & caps



**Bath & Shower Gel 20ml**  
NEV-TUDG020, ctn qty 500  
Biodegradable plastic tubes & caps



**Body Lotion 20ml**  
NEV-TUBL020, ctn qty 500  
Biodegradable plastic tubes & caps



**Conditioning Shampoo 20ml**  
NEV-TUCS020, ctn qty 500  
Biodegradable plastic tubes & caps



**Vegetable Soap 15g**  
NEV-SOAP015, ctn qty 500  
Biodegradable plastic sachets



**Vegetable Soap 20g  
- pleat wrapped paper**  
NEV-SOAP020, ctn qty 400



**Wheat Soap 40g  
- pleat wrapped paper**  
NEV-SOAP040, ctn qty 200



**Conditioning Shampoo 10ml**  
NEV-SACS010, ctn qty 500  
Biodegradable plastic sachets



**Shower Cap**  
NEV-SHCA000, ctn qty 500  
Recyclable paper packaging



**Sanitary Bag**  
NEV-SABA000, ctn qty 500  
Recyclable paper packaging



**Vanity Set**  
NEV-VASE000, ctn qty 500  
Recyclable paper packaging



ECOspa



## ECO Spa Collection

ECO Spa in 20ml biodegradable tubes is the ideal collection for short-stay accommodation or the budget-minded operator. With the addition of a Conditioning Shampoo, ECO Spa can be offered in a three-tube combination, reducing the range even further. Offered in the same relaxing fragrances as the larger SPA in 30ml, ECO Spa is equally as refreshing for body and mind. SPA's subtle and invigorating fragrances compliment the vibrant blue colour tones, which reflect the vivid blue of Australia's sky and oceans.



**Shampoo 20ml**  
ECO-TUHS020, ctn qty 500  
Biodegradable plastic tubes & caps



**Conditioner 20ml**  
ECO-TUCO020, ctn qty 500  
Biodegradable plastic tubes & caps



**Bath & Shower Gel 20ml**  
ECO-TUDG020, ctn qty 500  
Biodegradable plastic tubes & caps



**Body Lotion 20ml**  
ECO-TUBL020, ctn qty 500  
Biodegradable plastic tubes & caps



**Conditioning Shampoo 20ml**  
ECO-TUCS020, ctn qty 500  
Biodegradable plastic tubes & caps



**Vegetable Soap 15g - in sachet**  
SPA-SOAP015, ctn qty 500



**Vegetable Soap 20g - pleat wrapped**  
SPA-SOAP020, ctn qty 500



**Shower Cap**  
SPA-SHCA000, ctn qty 500



**Vanity Kit**  
SPA-VASE000, ctn qty 500



**Sanitary Bag**  
SPA-SABA000, ctn qty 500



**Luxury Bath Crystals, 60g tub**  
HY-ACSA001, ctn qty 120



spa

## Spa Collection

With SPA we recognize the importance of relaxation. Its mild and soothing ingredients are formulated to help relax and refresh body and mind. SPA's subtle and invigorating fragrances compliment the vibrant blue colour tones, which reflect the vivid blue of Australia's sky and oceans. These products help to unwind and recharge, while creating a gentle spa experience. The premium presentation and styling of the SPA range makes this hotel cosmetics collection suitable for every quality hotel, motel and resort.



**Shampoo 30ml**  
SPA-TUHS030, ctn qty 400



**Conditioner 30ml**  
SPA-TUCO030, ctn qty 400



**Bath & Shower Gel 30ml**  
SPA-TUDG030, ctn qty 400



**Body Lotion 30ml**  
SPA-TUBL030, ctn qty 400



**Vegetable Soap 15g - in sachet**  
SPA-SOAP015, ctn qty 500



**Vegetable Soap 20g - pleat wrapped**  
SPA-SOAP020, ctn qty 500



**Shower Cap**  
SPA-SHCA000, ctn qty 500



**Sanitary Bag**  
SPA-SABA000, ctn qty 500



**Vanity Kit**  
SPA-VASE000, ctn qty 500



**Luxury Bath Crystals, 60g tub**  
HY-ACSA001, ctn qty 120



**Acrylic Tray - clear, with bevelled edges**  
SWS-APTC000, ctn qty 50  
size: 270 x 110 x 10mm



# AROMA THERAPY



## Aroma Therapy

AROMA THERAPY toiletries are designed to pamper and indulge your guests in a world of soft fragrances. These aromatic bathroom cosmetics are formulated with essences of White Tea, Red Tea and Ginger and offer a subtle and satisfying sense of relaxation for body and mind. AROMA THERAPY hotel amenities also combine luxury Body Care with biodegradable packaging.



**Shampoo 30ml**  
ARO-BOHS030, ctn qty 300  
White Tea, Red Tea and Ginger



**Conditioner 30ml**  
ARO-BOCO030, ctn qty 300  
White Tea, Red Tea and Ginger



**Bath & Shower Gel 30ml**  
ARO-BODG030, ctn qty 300  
White Tea, Red Tea and Ginger



**Body Lotion 30ml**  
ARO-BOBL030, ctn qty 300  
White Tea, Red Tea and Ginger



**Conditioning Shampoo 30ml**  
ARO-BOCS030, ctn qty 300  
Biodegradable plastic bottles & caps



**Conditioning Shampoo 10ml**  
ARO-SACS010, ctn qty 500  
Biodegradable plastic sachet



**Vegetable Soap 15g**  
ARO-SOAP015, ctn qty 500  
Biodegradable plastic sachets



**Vegetable Soap 20g - waterproof paper wrap**  
ARO-SOAP020, ctn qty 400



**Vegetable Soap 40g - waterproof paper wrap**  
ARO-SOAP040, ctn qty 200



**oasis**



## Oasis

Surprise your guests with a splash of colour and fun in the bathroom! Oasis and its green/blue colour scheme makes for a great match in both country and seaside hotels. The featured animal skin patterns are cheeky and in line with current fashion trends. Formulated with fresh and uplifting coconut and cocoa fragrances. Oasis is a down-right crowd-pleaser. This fun loving toiletries range will meet tight budgets and please your guests - young and old alike. All products are packaged in environmentally friendly, degradable and recyclable packaging and all formulations are paraben free.



**Shampoo 20ml**  
OAS-TUHS020, ctn qty 500



**Conditioner 20ml**  
OAS-TUCO020, ctn qty 500



**Bath & Shower Gel 20ml**  
OAS-TUDG020, ctn qty 500



**Body Lotion 20ml**  
OAS-TUBL020, ctn qty 500



**Conditioning Shampoo 20ml**  
OAS-TUCS020, ctn qty 500



**Vegetable Soap 15g - in sachet**  
OAS-SOAP015, ctn qty 500



**Vegetable Soap 20g - pleat wrapped**  
OAS-SOAP020, ctn qty 400



**Amenity Set - front & side view**  
OAS-AMSE003, ctn qty 500  
incl. Shower Cap & Sanitary Bag



**Acrylic Tray - clear, with bevelled edges**  
SWS-APTC000, ctn qty 50  
size: 270 x 110 x 10mm



## Body Zone Collection

Treat your guests to some unexpected moments of self-indulgence with the luxury Body Zone Collection. Enhanced guest experiences and unexpected moments of pleasure are more important than ever, as guests are increasingly looking for more than just a hotel room. Body Zone Collection Toiletries are formulated with wonderful ingredients that treat all senses. The luxury key ingredient Moroccan Argan Oil is high in Vitamin E, Omega 3 and Antioxidants, working tirelessly to keep skin, hair and body nourished and youthful. Body Zone Amenities are available with a range of display trays for a perfect presentation.



**Vitalising Shampoo 30ml with Argan Oil & Vitamin E**  
BOZ-TUHS030, ctn qty 400



**Nourishing Conditioner 30ml with Argan Oil & Vitamin E**  
BOZ-TUCO030, ctn qty 400



**Hydrating Body Wash 30ml with Argan Oil & Vitamin E**  
BOZ-TUDG030, ctn qty 400



**Moisturizing Body Lotion 30ml with Argan Oil & Vitamin E**  
BOZ-TUBL030, ctn qty 400



**Vegetable Soap 20g**  
BOZ-SOAP022, ctn qty 400



**Vegetable Soap 40g**  
BOZ-SOAP044, ctn qty 300



**Amenity Set small**  
BOZ-AMSE444, ctn qty 500  
incl. Shower Cap & Sanitary Bag



**Amenity Set large**  
BOZ-AMSE555, ctn qty 500  
incl. Shower Cap, Sanitary Bag, Vanity Set w. Nail File & Sewing Kit



**Shaving Set**  
BOZ-SHKIO44, ctn qty 250  
incl. Schick Razor & Shaving Cream



**Dental Set**  
BOZ-DEKIO44, ctn qty 250  
incl. Travel Toothbrush & Colgate Toothpaste



OLIVE OIL  
SKINCARE COMPANY

## Olive Oil Skincare Company

Proudly Australian, OLIVE OIL SKINCARE stands for natural products, highest quality ingredients and represents one of our country's fastest growing hair and skin care brands. OLIVE OIL SKINCARE products contain 100% Extra Virgin Olive Oil and Australian Essential Oils. This premium hotel range is free from additives and artificial fragrances of any kind - offering your guests an all-natural Australian hair & skin care experience.



**Hair Shampoo 30ml**  
OLV-TUHS030, ctn qty 100  
with 100% extra virgin Olive Oil



**Hair Conditioner 30ml**  
OLV-TUCO030, ctn qty 100  
with 100% extra virgin Olive Oil



**Body Wash 30ml**  
OLV-TUDG030, ctn qty 100  
with 100% extra virgin Olive Oil



**Body Lotion 30ml**  
OLV-TUBL030, ctn qty 100  
with 100% extra virgin Olive Oil



**Vegetable Soap 20g**  
OLV-SOAP020, ctn qty 500  
with 100% extra virgin Olive Oil



**Bamboo Tray with acrylic pad,  
water proof**  
OLV-BATRO00, ctn qty 40  
size: 260 x 100 x 10mm



# BioNaturals



## BioNaturals

BioNaturals gives an elemental, positive spirit and provides healthy, fresh body power, thanks to carefully selected botanical extracts and oils from controlled organic cultivation. It contains selected organic ingredients as olive, lemon and orange, refreshes the body with valuable essential oils and pampers the skin with nourishing olive oil. A care line with precious vitamins, acids and minerals. Furthermore BioNaturals directly contributes to environmental protection. BioNaturals - a completely natural cosmetic line, which is not only good for nature, but also good for the guest!



**Hair Shampoo 30ml**  
NA-TUHS030, ctn qty 210  
With organic Orange extract



**Hair Conditioner 30ml**  
NA-TUCO030, ctn qty 210  
With organic Olive Leaf extract



**Shower Gel 30ml**  
NA-TUDG030, ctn qty 210  
With organic Lemon extract



**Body Lotion 30ml**  
NA-TUBL030, ctn qty 210  
With organic Olive Oil



**Vegetable Soap 20g - paper wrapped**  
NA-HWSF020, ctn qty 250



**Bath Salts 50g - in jar**  
NA-TISA050, ctn qty 120, Bath Salt  
with organic lemon extracts 50g





# PURE HERBS



## Pure Herbs

Pure Herbs Hotel Amenities are inspired by the richness of Nature and provide organic energy for Body & Soul. The Pure Herbs range is formulated with a carefully selected mix of precious herbal extracts from Rosemary, Melissa and Thyme. These high quality products are dermatologically tested and kind to the skin, with a balanced pH value of 5.5.



**Vitalizing Shampoo 35ml**  
PH-CTHS035, ctn qty 220  
Rosemary, Melissa and Thyme



**Softening Conditioner 35ml**  
PH-CTCO035, ctn qty 220  
Rosemary, Melissa and Thyme



**Energizing Bath & Shower Gel 35ml**  
PH-CTDG035, ctn qty 220  
Rosemary, Melissa and Thyme



**Soothing Body Lotion 35ml**  
PH-CTBL035, ctn qty 220  
Rosemary, Melissa and Thyme



**Purifying Body Exfoliant 35ml**  
PH-CTKP035, ctn qty 220



**Vegetable Soap 15g - in sachet**  
PH-SBRI015, ctn qty 500



**Vegetable Soap 30g  
in soft bag**  
PH-SBRE030, ctn qty 200



**Vegetable Soap 50g - in soft bag**  
PH-SBRE050, ctn qty 150



## Olive Oil Skincare

What started as a family project in an Australian home back in 2012, ended up as a leading skincare brand being exported worldwide. The health and beauty benefits of Extra Virgin Olive Oil have been known and applied since 5,000 BC. Its composition equally nourishes and enriches body and soul; improving flexibility and elasticity as well as regenerating and regulating the natural systems of skin and hair.



**Olive Oil Skincare Shampoo, Citrus Bloom, 500mL**  
OLV-PSHS-500, ctn qty 12



**Olive Oil Skincare Conditioner, Citrus Bloom, 500mL**  
OLV-PSCO-500, ctn qty 12



**Olive Oil Skincare Hand & Body Wash, Naturally Nourished, 500mL**  
OLV-PSHBW-500, ctn qty 12



**Olive Oil Skincare Hand & Body Lotion, Naturally Nourished, 500mL**  
OLV-PSBL-500, ctn qty 12



**Olive Oil Skincare Shampoo, Citrus Bloom, 5L Refill**  
OLV-PSHS-5L, ctn qty 2



**Olive Oil Skincare Conditioner, Citrus Bloom, 5L Refill**  
OLV-PSCO-5L, ctn qty 2



**Olive Oil Skincare Hand & Body Wash, Naturally Nourished, 5L Refill**  
OLV-PSHBW-5L, ctn qty 2



**Olive Oil Skincare Hand & Body Lotion, Naturally Nourished, 5L Refill**  
OLV-PSBL-5L, ctn qty 2

**Single Wall Holder, Matte Black**  
SWS-PSHA501-BK, ctn qty 1

**Single Wall Holder, Matte White**  
SWS-PSHA501-WH, ctn qty 1

**Double Wall Holder, Matte White**  
SWS-PSHA502-WH, ctn qty 1

**Double Wall Holder, Matte Black**  
SWS-PSHA502-BK, ctn qty 1

**Triple Wall Holder, Matte Black**  
SWS-PSHA503-BK, ctn qty 1

**Triple Wall Holder, Matte White**  
SWS-PSHA503-WH, ctn qty 1



# Bathroom Accessories



**PURE WHITE  
COLLECTION**

*Pure White Collection*



**Shower Cap & Hair Band - in card pack**  
PUR-SHCA000, ctn qty 500



**Sanitary Bag - in card pack**  
PUR-SABA000, ctn qty 500



**Vanity Set - in card pack**  
PUR-VASE000, ctn qty 500  
Cotton Pads and Cotton Tips



**Dental Kit - in card pack**  
PUR-DEKI000, ctn qty 500  
Toothbrush and Colgate Toothpaste



**Shaving Kit - in card pack**  
PUR-SHKI000, ctn qty 500  
Schick Razor and Shaving Cream



**Sewing Kit - in card envelope**  
PUR-SEKI000, ctn qty 1000



**Shoe Polish Sponge - in card pack**  
PUR-SHOE0000, ctn qty 500



**Nail File & Cuticle Stick - in card pack**  
PUR-NASE000, ctn qty 1000



## BLACK LABEL COLLECTION

### Black Label Collection



**Amenity Set, large**  
BUE-AMSE333, ctn qty 500  
incl. Shower Cap, Sanitary Bag,  
Vanity Set w. Nail File & Sewing Kit



 **Amenity Set, large**  
BUE-AMSE111, ctn qty 500  
incl. Shower Cap, Sanitary Bag,  
Vanity Set w. Nail File & Sewing Kit



**Amenity Set, small**  
BUE-AMSE222, ctn qty 500  
incl. Shower Cap & Sanitary Bag



## Make-Up Remover



**Make-Up Remover Wipes**  
SWS-MURW000, ctn qty 1000

## Dishwashing & Laundry



**Liquid Dishwashing Detergent 20ml**  
SWS-DILIO20, ctn qty 500



**Liquid Laundry Detergent 20ml**  
SWS-LALI020, ctn qty 500



**Laundry Powder 20g**  
SWS-LAPO020, ctn qty 500



**Automatic Dishwashing Powder 12g**  
SWS-ADPO012, ctn qty 500

# Amenities Trays



**Acrylic Tray - black, rectangular**  
PFTB006, ctn qty 5  
size: 243 x 107 x 10mm



**Acrylic Tray - clear, with bevelled edges**  
SWS-APTC000, ctn qty 50  
size: 270 x 110 x 10mm



**Acrylic Tray - clear, with blue-green tint**  
SWS-AATG000, ctn qty 40  
size: 285 x 140 x 27mm



 **Acrylic Tray - white, rectangular**  
PFTB007, ctn qty 5 size: 243 x 107 x 10mm



**Melamine Tray Zen Line - black, rectangular**  
JVD-866893, ctn qty 12  
size: 295 x 155 x 10mm



 **PU Leather Tray - black, rectangular**  
SWS-PUTY000, ctn qty 50  
size: 300 x 100 x 15mm



 **Resin Presentation Stand - granite, 2-tier**  
SWS-2TRE000, ctn qty 20  
size: 250 x 120 x 85mm







## Innovation in the service of well-being

The strength of JVD resides in our provision of accessories adorning hotel rooms around the world for more than 30 years. JVD accessories help to personalize hotel rooms, giving them the final touch to ensure guests' well-being. Accessories are what truly make a difference.

Safes • Minibars • Hair Dryers • Kettles • Iron Centre • Mirrors • Room Accessories • Hygiene

GLOBALLY CONNECTED AND LOCALLY FOCUSED, SWISSTRADE BRINGS A WHOLE NEW WORLD OF GUEST ROOM EXPERIENCES TO OUR REGION.



## JVD's Values and Talent



### Smart

Our products are designed to be used by anyone, from children to maintenance personnel to people with reduced mobility. Not only are they suited to their environments but they are also safe, practical and ergonomic.



### Service Orientation

Customer satisfaction is part of JVD's DNA. And so our teams work hard to guarantee impeccable quality, short turnaround times and flawless customer service.

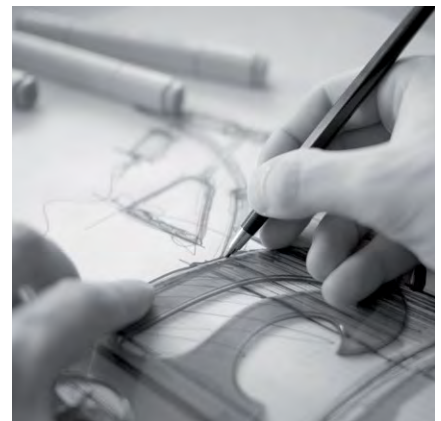

### Research & Development

Managed internally by our R&D Centre, each of our products is designed in accordance with our ongoing strategy of pursuing innovative solutions. Elegance, design and ergonomics are the keys to a successful product.



# JVD's Commitment to Responsibility

Eco-responsibility has been one of JVD's pillars from the very beginning. The company's commitment on this subject only grows stronger every day and now concerns each of its different levels. JVD is dedicated to the idea of transmission and makes it a point of honour to play an active role in an ecological transition which looks out for everyone's well-being.



## Working & Preserving

We have always been convinced that the strategy of today should be to improve the future of tomorrow. All the teams at JVD strive actively to think of everything and to make a real difference. From design to manufacturing, transport to use and customer service to recycling, we know that each detail counts.



## Eco-Design

Kettles are designed to be smaller in size to reduce water wastage, minibars are made to run on advanced energy saving thermo-absorption system and produce zero greenhouse gas. Our amenity trays do not involve usage of wood for a greener environment.



## Raw Materials & Partners

Eco-responsibility also concerns our choice of raw materials and partners. Whenever possible, we prioritize partners located as close as possible to our production unit so as to reduce the environmental impact of our transport. For years, we have been striving to ensure that expertise endures and so encourage our suppliers' capacity for innovation. Out of concern for our social impact, we work with associations from the social and solidarity economy.

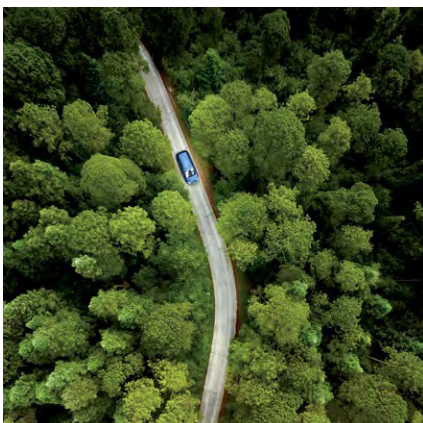

## Manufacturing

All our waste is sorted and collected before being sent to a treatment and recycling centre. For example, we reuse our suppliers' cardboard boxes for our shipments, and we grind used paper and then use it as wedges for our shipped products. What about the rest? It is recycled or reused by other companies in the region!



## Combating Planned Obsolescence

At JVD, our products are designed and tested to be repairable and to repair them. Our appliances' spare parts are available for 10 years. Quality products meant to work and be used for the long term.



## Logistics

Our packaging is designed with a twofold objective: to protect the integrity of the transported goods and to serve as an installation diagram. These simple, sensible optimizations further reduce our carbon footprint.



**Guest Room Equipment** | Safes



# SAFES

JVD safes are synonymous with peace of mind. Give your guests access to a robust, secure storage solution for their belongings and you can rest easy. JVD Room Safe solutions are simple and easy to manage and meet stringent hotel brand standards.

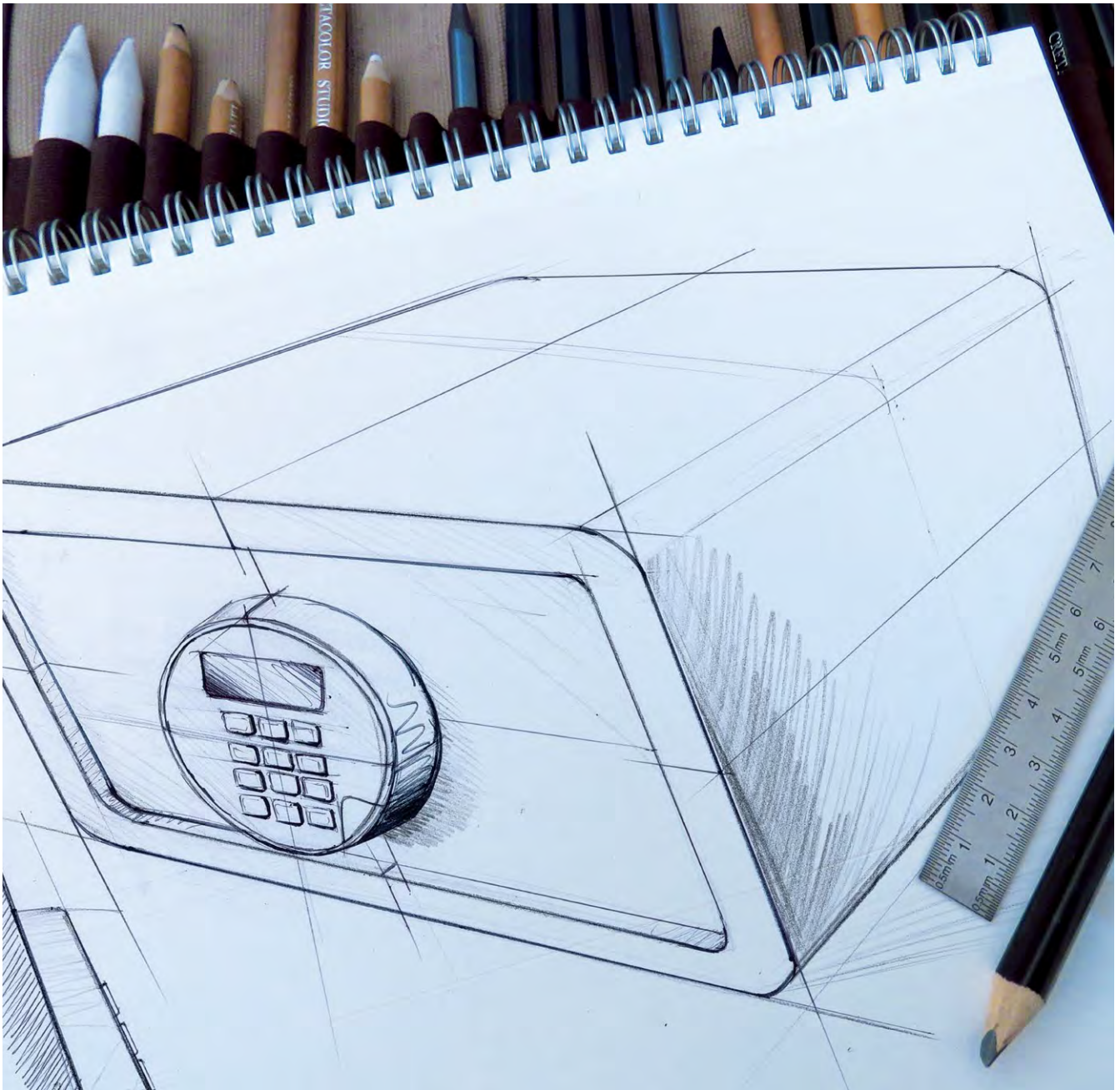

## SECURE

In-room security is serious business... You need a Serious Partner. JVD safes is a testimony of JVD continuous development in good technology and new techniques to enhance the pleasure and safety in in-room security.

## INTELLIGENT

JVD safes are powered by advance electronic system engineered to provide maximum security and convenience. They are equipped with anti-tamper labyrinth, security lock-out and audit trail features giving users peace of mind.

## LUXURIOUS

JVD safes offer impressive benefits and a better way to further extend your hospitality to your valued guests. It is a long term investment in quality. User-friendly functions, lighted keypad panel and internal light, etc make the JVD safes a luxurious amenity for guests.



## FORTRESS - Front Open



REF **FTS 195-LPT**  
Fortress 14" laptop  
H195/W355/  
D430mm  
UPC 1



REF **PSU**  
Service Unit  
UPC 1

### FORTRESS

- Code locking (4 to 6 digits)
- Power 4x1.5V AA cells
- 20mm diam. dual steel bolts
- Anti-tamper labyrinth
- Inside light and buzzer
- Lighted LED keypad buttons
- Non-volatile memory system
- Security lock-out 15 minutes
- Audit trail 200 past events
- Fastening at base and back
- Prolog electronic override
- Mechanical override

### DIMENSIONS

- **FTS 195-LPT 14"**  
- H195/W355/D430mm
- **FTS 205-LPT 15"**  
- H205/W435/D420mm

## ICONIC PLUS - Top Open



REF **ITO PLUS 130**  
Iconic Plus 15"  
laptop  
H130/W400/  
D350mm  
UPC 1



REF **ITO PLUS 130-SLPT**  
Iconic Plus 17"  
superlaptop  
H130/W460/  
D350mm  
UPC 1



### ICONIC PLUS

- Code locking (4 to 6 digits)
- Power 4x1.5V AA cells
- 20mm diam. dual steel bolts
- Anti-tamper labyrinth
- Inside light and buzzer
- Lighted LED keypad buttons
- Non-volatile memory system
- Security lock-out 15 minutes
- Audit trail 200 past events
- Fastening at base and back
- Prolog electronic override
- Mechanical override

### ITO Plus 130

- Dimensions H130/W400/D350mm
- Accomodate most 15" laptops

### ITO Plus 130-SLPT

- Dimensions H130/W460/D350mm
- Accomodate most 17" laptops

## CUSTODIAN - Drawer Open



REF **CDS 205**  
Custodian Drawer  
H205/W475/  
D370mm  
UPC 1



REF **CSU SERVICE UNIT**  
UPC 1

### CUSTODIAN

- Code locking (4 to 6 digits)
- Power 4x1.5V AA cells
- 20mm diam. dual steel bolts
- Anti-tamper labyrinth
- Inside light and buzzer
- Lighted LED keypad buttons
- Non-volatile memory system
- Security lock-out 15 minutes
- Audit trail
- Fastening at base and back
- Custodian electronic override
- Mechanical override

### CS 200-LPT

- Audit trail 100 past events
- Dimensions H200/W420/  
D370mm
- Accomodate most 15" laptops

### CDS 205

- Audit trail 200 past events
- Dimensions H205/W475/D370mm
- Accomodate most 15" laptops

MANAGEMENT AND  
UNLOCKING CONTROL



## Guest Room Equipment | Minibars

# MINIBARS

## THERMO-ABSORPTION

JVD minibars are completely silent during operation, offering maximum comfort to your staying guests. They are available in different capacities to suit your cabinet and come complete with LED interior lighting as well as quality lock. Purchasing a JVD silent minibar is a long-term investment in quality.

### FEATURES

1. **100%** Silent 24 hours a day
2. **100%** Ecological
3. **66%** Less Consumption
4. **100%** Reliable: no motor, no moving parts

### Ventilation Requirement

When integrating the minibar into your hotel room cabinet, it is crucial that the surrounding area of the minibar has unhindered airflow and good heat dissipation.

To get the best performance, the minibar needs at least 200cm<sup>2</sup> free air inlet. This space should be kept until the air outlet at the cabinet surface top. Rear of the minibar should be at least 50mm clear from the furniture wall.

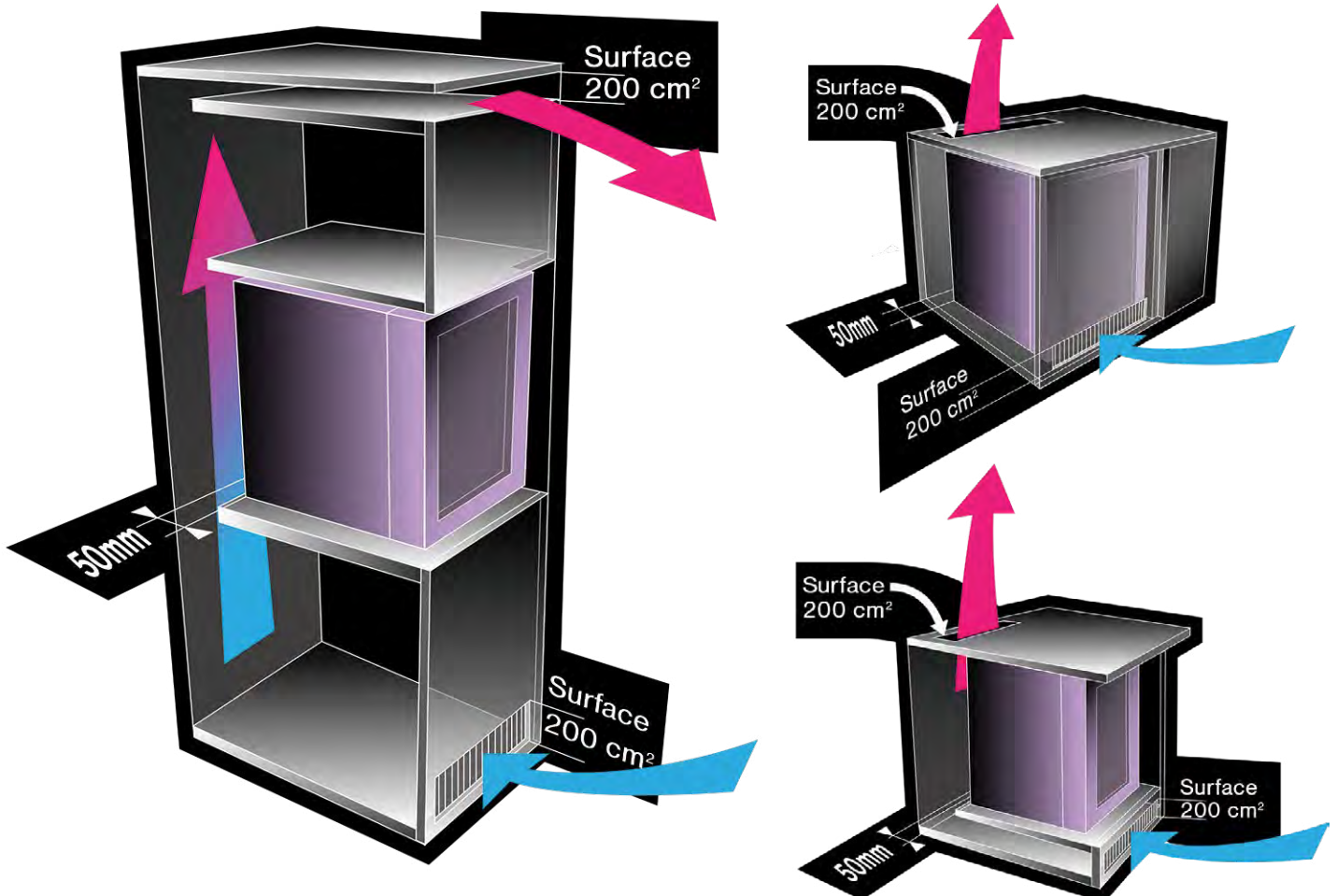



## THERMO-ABSORPTION - 30L



REF **EC 30**  
Solid door 30L  
H475/W385/D425mm  
UPC 1



REF **EC 30-GD**  
Glass door 30L  
H475/W385/D425mm  
UPC 1

### 30L THERMO-ABSORPTION

- 100% silent operation
- Low energy consumption
- Gross capacity 30 litre
- Thermo-absorption system
- Ozone friendly
- Non-toxic R600A refrigerant
- Automatic defrosting
- Interior LED lighting
- Tempered glass shelf
- Quality lock included
- Magnetic door insulation
- Reversible door option

### EC30 Solid Foam Door

- Dim. H475/W385/D425mm
- Power 220V-240V 63W
- Energy consumption 0.266 kWh/24hrs - Energy Class A+

### EC30-GD Glass Door

- Dim. H475/W385/D425mm
- 3-ply tempered glass door
- Power 220V-240V 63W
- Energy consumption 0.275 kWh/24hrs - Energy Class A+



## THERMO-ABSORPTION - 40L



REF **EC40**  
Solid door 40L  
H560/W400/D420mm  
UPC 1



### 40L THERMO-ABSORPTION

- 100% silent operation
- Low energy consumption
- Gross capacity 40 litre
- Thermo-absorption system
- Ozone friendly
- Non-toxic R600A refrigerant
- Automatic defrosting
- Interior LED lighting
- Tempered glass shelf
- Quality lock included
- Magnetic door insulation
- Reversible door option

### EC40 Solid Foam Door

- Dim. H560/W400/D420mm
- Power 220V-240V 63W
- Energy consumption 0.269 kWh/24hrs - Energy Class A+

### EC40 Glass Door

- Dim. H560/W400/D420mm
- 3-ply tempered glass door
- Power 220V-240V 63W
- Energy consumption 0.278 kWh/24hrs - Energy Class A+



REF **EC40-GD**  
Glass door 40L  
H560/W400/D420mm  
UPC 1

## DRAWER MINIBAR - 40L



REF **DM 40-BK**  
Drawer minibar 40L  
+ door handle  
UPC 1



REF **DM 40-BK-NH**  
Drawer minibar 40L  
UPC 1

### DRAWER MINIBAR THERMO-ELECTRIC

- Power 220V-240V 65W
- Energy consumpt. 0.37 kWh/24hrs
- Dimensions H412/W495/D455mm
- Low energy consumption
- Gross capacity 40 litre
- Thermo-electric system
- In-built fans included for heat dissipation
- Quiet operation
- Automatic defrosting
- Interior LED lighting
- Adjustable inner dividers
- Candy bar drawer included
- Magnetic door insulation

### DM 40-BK

- Stand-alone unit with handle

### DM 40-BK-NH

- For attachment to outer cabinet panel



# SMART COMPRESSOR MINIBAR

## A NEW GENERATION OF MINIBARS

**JVD SMART COMPRESSOR** minibars are with next-gen smart technologies. The control panel allows users to activate quick cooling when it matters most and silences the unit when needed.

JVD Smart CPE minibars operate on ultra-low energy consumption (energy class A+++).



REF **CPE 30/ CPE 40 -BK**  
Smart Compressor  
Minibar  
Solid Door 30L / 40L  
UPC 1



REF **CPE 30**  
Smart Compressor  
Minibar  
Solid door 30L  
UPC 1



REF **CPE 30-GD**  
Smart Compressor  
Minibar  
Glass door 30L  
UPC 1



REF **DM-CP50**  
Drawer Minibar 50L  
Smart-Compressor UPC 1



### JVD SMART minibars

- Quick cooling for new replenishment
- Completely silent when guest is resting
- No compromise on cooling performance
- Very low energy consumption
- Highest Class A+++ rating

- Solid foam door or 3-ply tempered glass door
- Smart compressor system
- Eutectic cold plate for enhanced cold preservation
- Refrigerant R600a, cyclopentane
- Power: 220V-240V 51W  
Consumption: 0.135 kWh/24hrs  
Class A+++
- Automatic defrosting
- Quality lock included
- Interior LED lighting
- Tempered glass shelve
- Magnetic door insulation
- Reversible door option
- CFC-free

### Dimensions

CPE 30/ CPE 30-GD  
- Dimensions H503/W402/D424mm

CPE 40/ CPE 40-GD  
- Dimensions H565/W402/D500mm

DM-CP50  
- Dimensions H420/W550/D490mm



**Guest Room Equipment** | Hair Dryers

# HAIR DRYERS

With a contemporary design and innovative technology our range of hair dryers is tailored to suit any style of bathroom.



## FEATURES

1. Choose between **cost effective DC engine** or **long-life AC motor**
2. Range of **surface finishes**
3. **Six air & heat settings** plus **ION technology** for superior hair care
4. **Ergonomic handles** and **weight balance**
5. **International standard curly power cord**
6. **Space-saving foldable handles**
7. **Hand-held and wall-mount options**
8. **Powerful air-flow** or **energy-saving models**

## CALISTO



**REF 8 22 1412**  
Calisto matt black  
2000W + curly cord  
& plug  
UPC 12

## IBIZA



**REF 8 22 919**  
Ibiza black 1875W  
+ straight cord &  
plug  
UPC 12



**REF 8 22 919-MB**  
Ibiza matt black  
1875W  
+ curly cord & plug  
UPC 12



**REF 8 22 1141-RM**  
Ibiza Plus soft-matt black  
2200W + curly cord & plug,  
UPC 12

### CALISTO - LUXURY HAIR DRYER

- Voltage 220-240V, 50/60Hz
- Power 2000W
- Long-life AC brushless motor
- Dimensions H266/L262/D89mm
- On/off switch system
- Ionic drying for protective drying & frizz free hair
- Spiral cord 40cm extendable
- 6 drying settings with cold shot
- Over-heating protection
- Removable nozzle & back filter
- Electrical insulation Class II

### IBIZA - A VERSATILE ALL-ROUNDER LONG-LIFE AC MOTOR

- Voltage 220-240V, 50/60Hz
- Power 1875W & 2200W
- Dimensions H205/L266/D90cm
- On/off switch system
- 6 drying settings with cold shot
- Ionic drying for protective drying & frizz free hair
- Spiral cord 40cm extendable
- Available with straight cord
- Over-heating protection
- Removable nozzle & back filter
- Electrical insulation Class II

## AMOR



REF **8 22 1564**  
Amor black 1800W  
+ straight cord &  
plug  
UPC 12

### **AMOR - THE ECONOMICAL LIGHT-WEIGHT DC MOTOR**

- Voltage 220-240V, 50/60Hz
- Power 1800W
- Dimensions H265/L219/D94cm
- DC motor
- Ionic drying for protective drying & frizz free hair
- Straight cord 2m
- 6 drying settings with cold shot
- Over-heating protection
- Removable nozzle & back filter
- Electrical insulation Class II

## KEOS - FOLDABLE



REF **8 22 1499**  
Keos foldable 1600W  
Black chrome filter  
+ curly cord & plug  
UPC 12

### **KEOS Foldable**

- Voltage 220-240V, 50/60Hz
- Power 1600W
- Folded H130/L180/D78mm
- Unfolded H253/L180/D78mm
- DC motor
- On/off switch system
- Spiral cord 40cm extendable
- 3 drying settings with cold shot
- Over-heating protection
- Removable back filter
- Electrical insulation Class II

## OCEANIS - DOUBLE CHROME



REF **8 22 414**  
Oceanis DC  
1600W  
Black + wall  
holder  
UPC 12

### OCEANIS DC

- Voltage 220-240V, 50/60Hz
- Power 1600W
- Dimension H200/L230/D120mm
- DC motor
- Double chrome design
- Hold button safety system
- Spiral cord 40cm extendable
- 3 drying settings with cold shot
- Over-heating protection
- Electrical insulation Class II

## PICCOLO - PRO



REF **8 22 1500**  
Piccolo Pro 1200W  
White + curly cord  
& plug  
UPC 16



REF **8 22 1502**  
Piccolo Pro 1200W  
White + wall-  
mounted holder  
UPC 16

### PICCOLO Pro

- Voltage 220-240V, 50/60Hz
- Power 1200W
- Dimension H220/L140/D70mm
- With holder H235/L162/D72mm
- DC motor
- On/off switch system
- Spiral cord 40cm extendable
- 3 drying settings with cold shot
- Over-heating protection
- Removable back filter

### PICCOLO Pro Holder

- With built-in power microswitch
- Automatic power off when placed back to holder



REF **8 22 1501**  
Piccolo Pro 1200W  
Black + curly cord  
& plug  
UPC 16



REF **8 22 1503**  
Piccolo Pro 1200W  
Black + wall-mounted  
holder  
UPC 16



## HOLD BUTTON RANGE

This range successfully combines a timeless design and absolute safety in mind with the hold-button function.



# HAIR DRYER ACCESSORIES

## WALL HOLDER



REF **8 66 1269**  
Alpino L holder  
Zinc alloy, chrome  
UPC 1



ANTI-THEFT  
Cable attached to wall

### ALPINO WALL-HOLDER

- With cable hook
- Anti-theft design
- Zinc alloy, rust resistance
- Chrome finishing

### REF 8661269

- for Alteo, Calisto, Ibiza models

## HAIR DRYER BAGS



REF **2 402 841**  
Dryer bag, black  
Velvet with print  
UPC 20



REF **2 402 835**  
Dryer bag, beige  
Velvet with print  
UPC 20

### HAIR DRYER BAGS

#### - Velvet

- 2402835, size 260/300mm, beige
- 2402841, size 310/310mm, black

#### - Non-woven

- 2402904, size 310/310mm, white
- 2402903, size 310/310mm, black



REF **2 402 903**  
Dryer bag, black  
Non-woven with  
print  
UPC 20



**SPECIAL  
+ ORDER +**

REF **2 402 902**  
Dryer bag, white  
Non-woven with  
print  
UPC 20





## **Guest Room Equipment**

| Kettles & Coffee Machines



# KETTLES & COFFEE MACHINES

Elegance, design and ergonomics: the threefold expectations which inspire our products. Over a cup of hot chocolate, tea or coffee, each moment becomes a time of comfort, relaxation and well-being.

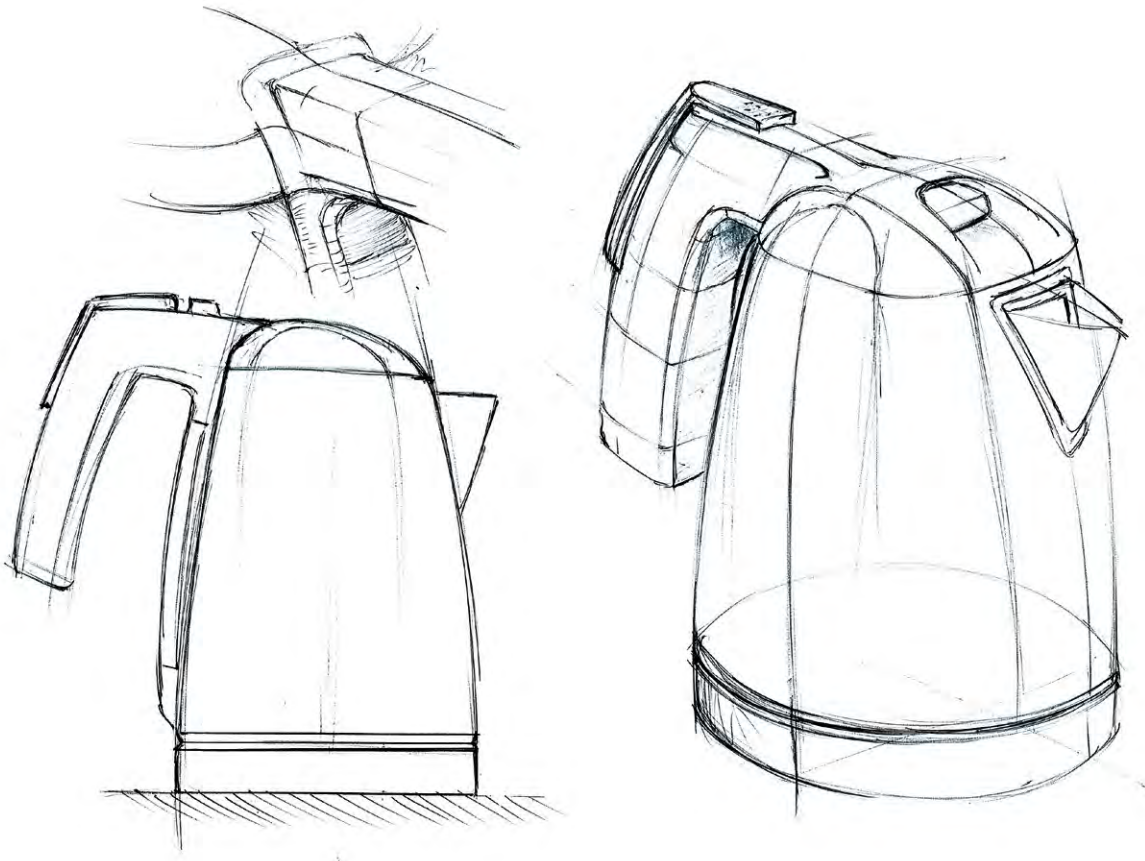

## KETTLES

Developed wholly in France by our Design Department in a combination of functionality, elegance and clever technology, our kettles accompany your guests' morning wake-up routines and moments of relaxation. Conceived specifically for hotels, they are also easy on your energy consumption

## COFFEE MACHINES

Our machines are designed to offer a simple solution which will make delicious espresso for your guests. No need for a dedicated space: thanks to their small size, they can fit anywhere.

## BREATHE COLORS

The Modus Vivendi Collection exemplifies harmony and diversity in guestroom living. The color range complement any designer's ideas and inspirations, making a stay away from home a colorful one.

## A word from the designer...

*In recent years, we have witnessed a profound change in hotel room design. We have shifted from often stereotypical settings to places for experiences. For guests, the time spent there should be atypical, personal and sometimes even surprising. Our products' design further contributes to this new trend. Arranged in increasingly varied environments, they add their own aesthetic touches whilst either fitting in seamlessly or boldly standing out. Naturally, in addition to their decorative aspects, each object must also offer services specific to a hotel room, in a way which is efficient, robust, safe and faithful to the hotel's philosophy. They should be simple, universal and ergonomic in their use. Our products are inspired by this twofold expectation of practicality and aesthetics.*

- Jean-Guy de Russé

## DIVA 1L



REF **8 66 1343**  
Diva 1L stainless steel  
+ double wall  
UPC 6



**SAFE**  
AUTOMATIC SHUT-OFF BY SIMPLY  
GRASPING THE SWITCHSAFE®  
SECURE HANDLE



**SAFETOUGH®**  
TRUE ANTI-SCALD WITH  
DOUBLE WALL USING STAINLESS  
STEEL AND THERMA-PLASTIC



**EASY OPENING**  
ONE-HAND OPENING WITH  
SPRING-ASSISTED LID



**TRAY FIXATION**  
DESIGNED FOR FIXATION TO JVD  
AMENITY TRAYS



Safe handling  
with JVD patented  
Switchsafe® handle

- DIVA**  
DOUBLE WALL. COOL TOUCH
- Voltage 220-240V, 50/60Hz
  - Power 1500W
  - Class 1
  - Capacity 1L
  - Switchsafe® handle
  - Interior 304 stainless steel
  - Auto off when boiled or empty
  - 360° rotation on the base
  - Concealed heating element
  - Water level indicator
  - Power light
  - Fixable to selected JVD trays
  - Dimensions H213/L145/D210mm

## SAISONS 1L



REF **8 66 1665**  
SAISONS 1L matt-black  
+ double wall  
UPC 6



**SPECIAL  
\*ORDER\***

REF **8 66 1693**  
SAISONS 1L sand gold  
+ double wall  
UPC 6

### SAISONS

DOUBLE WALL, COOL TOUCH

- Voltage 220-240V, 50/60Hz
- Power 800-950W, Class 1
- Capacity 1L
- Interior 304 stainless steel
- Exterior thermo-plastic housing
- Auto off when boiled or empty
- 360° rotation on the base
- Concealed heating element
- Water level indicator
- Power light
- Dimensions H230/L148/D200mm

## LUXE 1L



REF **8 66 1682**  
LUXE 1L  
Stainless steel matt  
UPC 8

### LUXE 1L

- Voltage 220-240V, 50/60Hz
- Power 1850-2200W, Class 1
- Capacity 1.0L
- Strix controller
- Auto off when boiled or empty
- 360° rotation on the base
- Concealed heating element
- Water level indicator
- Power light
- Dimensions H201/L126/D208mm



Safe handling  
with JVD patented  
Switchsafe® handle

## DUCHESSÉ 0.8L



REF **8 66 914**  
DUCHESSÉ 0.8L  
Stainless steel matt  
UPC 12

### DUCHESSÉ 0.8L

- Voltage 220-240V, 50/60Hz
- Power 1250W
- Class 1
- Capacity 0.8L
- Switchsafe® handle
- Auto off when boiled or empty
- 360° rotation on the base
- Concealed heating element
- Power light
- Dimensions H197/L128/D209mm

## DUCHESSÉ 0.6L



REF 8 66 759  
DUCHESSÉ 0.6L  
black  
UPC 12

## MARQUISE 0.6L



REF 8 66 1664  
MARQUISE 0.6L  
Stainless steel matt  
black  
UPC 12

### DUCHESSÉ 0.6L

- Voltage 220-240V, 50/60Hz
- Power 800W, Class 1
- Capacity 0.6L
- Switchsafe® handle
- Auto off when boiled or empty
- 360° rotation on the base
- Concealed heating element
- Power light
- Dimensions H190/L127/D206mm

### MARQUISE 0.6L

- Voltage 220-240V, 50/60Hz
- Power 1000W
- Class 1
- Capacity 0.6L
- 304 stainless steel
- Auto off when boiled or empty
- 360° rotation on the base
- Concealed heating element
- Power light
- Dimensions H178/L121/D182mm

## DUCHESSÉ - 0.8L



REF 8 66 1010  
DUCHESSÉ 0.8L  
white UPC 12



REF 8 66 1011  
DUCHESSÉ 0.8L  
black  
UPC 12



REF 8 66 1014  
DUCHESSÉ 1L black  
UPC 12

### DUCHESSÉ 0.8L

- Voltage 220-240V, 50/60Hz
- Power 1250W, Class 1
- Capacity 0.8L
- Auto off when boiled or empty
- 360° rotation on the base
- Concealed heating element
- Power light
- Dimensions H205/L135/D223mm

### DUCHESSÉ 1L

- Voltage 220-240V, 50/60Hz
- Power 1250W, Class 1
- Capacity 1L
- Auto off when boiled or empty
- 360° rotation on the base
- Concealed heating element
- Power light
- Dimensions H205/L135/D223mm

## ZENITH - 0.8L



REF 8 66 375  
ZENITH 0.8L white  
UPC 12



REF 8 66 377  
ZENITH 0.8L black  
UPC 12

### ZENITH 0.8L

- Voltage 220-240V, 50/60Hz
- Power 1250W
- Class 1
- Capacity 0.8L
- Water level indicator
- Auto off when boiled or empty
- 360° rotation on the base
- Concealed heating element
- Power light
- Fixable to selected JVD trays
- Dimensions H190/L125/D200mm

# Pod&Parcel

Specialty Biodegradable  
Coffee Pods



Biodegradable Coffee Pods

# We're an Australian, family-owned brand who strive for high quality in everything we do.

That's why we source the best goods from top producers in Australia and around the world. Our coffees are expertly tried and tasted for quality, and curated to deliver an exceptional guest experience without impacting our world.



# We're serious about quality.

## Coffee Pod Product Specifications

- All our coffee is specialty-grade.
- The pod capsule and sleeve are biodegradable and compostable, breaking down within 90 days in a commercial composting facility.
- Compatible with Nespresso Original Coffee Machines.

## Certifications and Ratings

- Our specialty-grade coffee is equal to or above 80 points on a 100-point scale, in accordance with the Specialty Coffee Association of America (SCAA) guidelines.
- Our biodegradability and compostability claims are in accordance with the EN13432 standard.
- Our capsule packing production facility is food safe and HACCP Certified.
- Our coffee roasting facility is food safe and HACCP Certified.







## FASOLI



**Pods 'Fasoli'**  
PP-CPSI-20-FAS  
Plum, dark berries and caramel  
Intensity 8/13 - Milk or Espresso  
UPC 200

## FLORENTINO



**Pods 'Florentino'**  
PP-CPSL-20-FLO  
Roasted walnut, cocoa and blackcurrant  
Intensity 12/13 - Milk  
UPC 200

## SIDAMO



**Pods 'Sidamo'**  
PP-CPSL-20-SID  
Sweet lemon, candied orange and fig  
Intensity 8/13 - Milk or Espresso  
UPC 200

## RUSIZI



**Pods 'Rusizi' Single Origin**  
PP-CPSL-20-RUS  
Raspberry, Stone Fruit and Syrup  
Intensity 11/13 - Milk or Espresso  
UPC 200

## MUNRO



**Pods 'Munro'**  
PP-CPSL-20-MUN  
Chocolate, Hazelnut and Fruit  
Intensity 9/13 - Milk  
UPC 200

## BANCROFT



**Pods 'Bancroft'**  
REF PP-CPSL-20-BAN  
Cocoa, Nougat and Molasses  
Intensity 9/13 - Milk  
UPC 200

\*Nespresso Compatible



## Tea Bags & Accessories



## T2 The Australian Tea Experience

Our service teabags come in bulk packs of 200 and are ready to dunk and go. Our individually wrapped teabags are designed for self-service and each teabag comes in its own black foil pouch.



**T2 Earl Grey Tea in Sachet**  
T2-B125AG046  
UPC 800 (4 x 200)



**T2 English Breakfast Tea in Sachet**  
T2-B120AG011  
UPC 800 (4 x 200)



**T2 Chamomile Tea in Sachet**  
T2-B140AG036  
UPC 800 (4 x 200)



**T2 Peppermint Tea in Sachet**  
T2-B140AG034  
UPC 800 (4 x 200)



**T2 Sencha Tea in Sachet**  
T2-B110AG009  
UPC 800 (4 x 200)



**T2 Takeaway Cup, 330ml**  
T2-C41000018  
UPC 100



**T2 Takeaway Cup Lid**  
T2-C41000019  
UPC 100



**T2 Wooden Presentation Caddy**  
T2-P99900051  
UPC 12



**T2 Wooden Presentation Tray**  
T2-P99900049  
UPC 12



**T2 Wooden Presentation Box with Lid**  
T2-P99900050  
UPC 6



**Guest Room Equipment** | Toasters

## SAHARA



REF **8 66 1350**  
Sahara  
UPC 6



REF **8 66 1350-BK**  
Sahara black  
UPC 6

### SAHARA

- Voltage 220V-240V 50/60Hz
- Power 780-930W
- Stainless steel housing
- 2 bread slices capacity
- Reheat/defrost/cancel function
- Removable crumb tray
- High lift to remove crumbs
- Size H188/W265/D156mm
- Available in stainless steel finish and stainless steel black color

## SAHARA COVER



REF **8 66 1575**  
Sahara cover  
UPC 20



### SAHARA Cover

- Polyester quilted fabric
- Classic diamond shaped stitching
- Heat resistant aluminium foam inner liner
- Oversized to fit most toasters
- Size H200/L290/D200



**Guest Room Equipment** | Irons & Boards



## LUXURY & PREMIUM STEAM IRONS



REF 8 66 1115-CM  
Vinci, 2200W,  
300ml  
Ceramic soleplate  
UPC 10



Safety : Irons come with auto shut-off after 30 seconds in a horizontal position or 8 minutes in a vertical position if there is no 'movement'



JVD irons come with 'smart-wrap' velcro to the power cord, making it neater and more durable



REF 8 66 923-CM (2000W)  
Vivo II 2000W, 300ml  
Cerami soleplate  
UPC 10



### VINCI / VIVO II (2000)

- Voltage 220V-240V, 50/60Hz

- Dry & steam iron
- Automatic power off system;
- Horizontal position 30 seconds
- Vertical position 8 minutes
- Dry/steam/spray/burst
- Anti-drip, anti-calc
- Self-cleaning function
- Fabric guide indicator
- Water capacity 300ml
- With 'smart-wrap' velcro



REF 8 66 923-CM  
Vivo II, 1600W,  
300ml  
Ceramic  
soleplate  
UPC 10



REF 8 66 1518  
Vienna, 1400W,  
200ml  
Ceramic  
soleplate  
UPC 12



Safety : Irons come with auto shut-off after 30 seconds in a horizontal position or 8 minutes in a vertical position if there is no 'movement'



JVD irons come with 'smart-wrap' velcro to the power cord, making it neater and more durable

**VIVO II/ VIENA/ VENUS**  
(VARY FOR DIFFERENT MODELS)

- Automatic power off system;
- Horizontal position 30 seconds
- Vertical position 8 minutes
- Dry/steam/spray/burst
- Anti-drip, anti-calc
- Self-cleaning function
- Fabric guide indicator
- Soleplate: stainless steel or ceramic
- With 'smart-wrap' velcro



## PRESTIGE BOARDS



REF **8 77 552-EB**

Prestige Off-white  
Silver cover, UPC 2



Bungee cover &  
padding in one-piece



REF **8 77 557-EB**

Prestige black  
Black cover, UPC 2

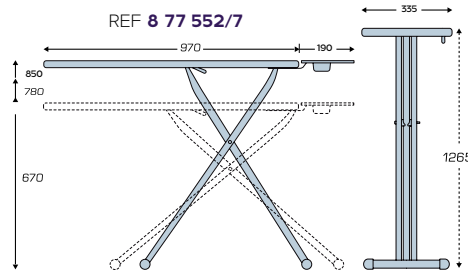

Board cover tested  
for heat resistance  
310° C

### PRESTIGE BOARDS

- Engineered for hotel use
- Heavy-duty, multi-welded
- Steel mesh top for good heat flow
- Complete with iron rest
- Automatic locking when folded
- Adjustable height
- Non-slip end caps

Model 877552-EB / 877557-EB

- Folded H1265/W335mm
- Iron surface 968/330mm

## IRONING BOARD COVERS



REF **8 88 517**

Black for Prestige  
877557



REF **8 88 512**

Silver for Prestige  
877552



### BOARD COVERS

- Bungee cover with padding
- Sewn together as one-piece
- Lrious 10mm thick
- Tested for heat up to 310° C
- One-piece bungee + padding
- No strings, easy and quick to install
- Fire-rated
- Luxurious 10mm thick

- 888 512 Silver for Prestige 877552
- 888 517 Black for Prestige 877557

## IRONGUARD



REF **8 66 1117 / 8 661519**  
 Ironguard black  
 Iron holder + board  
 hanger  
 UPC 12



REF **8 66 1116 / 8 66 1535**  
 Ironguard off-white  
 Iron holder + board  
 hanger  
 UPC 12

## IRON CADDY



REF **8 66 1022**  
 Iron caddy, beige  
 UPC 12



REF **8 66 1074**  
 Iron caddy, black  
 UPC 12



Heat  
 resistant

### IRONGUARD

Iron holder + board hanger

- Space saving system
- Engineered for hotel use
- Made of heavy-duty ABS plastic
- With heat-resistant buttons
- Hold iron securely
- With handy cord wrap

REF: 866 1116 (White)  
 REF: 866 1117 (Black)  
 - For Vinci & Vivo irons  
 - H365mm/W141/D170mm

REF: 866 1535 (White)  
 REF: 866 1519 (Black)  
 - For Viena, Venus & Vino irons  
 - H325/W125/D155mm

### IRON CADDY

- Designed to store iron
- Oversized to fit most irons
- Internal heat resistant
- Tested to 310° C
- With heavy-duty zip
- Dimensions H160/W300/D150mm



## Guest Room Equipment

# BLUETOOTH SPEAKER ALARM CLOCKS

## MUSE





**8 66 1610**  
MUSE, grey or black  
Alarm + 2 USB +  
bluetooth  
UPC 12



REF **9 03 204-ATL**  
Anti-theft cable  
Stainless steel  
UPC 20

### GENTLE WAKE UP TO ....

 SOUNDS OF NATURE

 BE GREETED BY SUNRISE

### MUSE BLUETOOTH CONNECTIVITY + IN-BUILT CHARGING CABLES

- Input: 110V-240V 50/60Hz
- Output: 12V 3A
- Adaptor included
- Back-up battery for auto power cutover
- Dimensions H180/W180/D40mm
- 3 levels of light dimming
- Wake up warm light
- 2 USB charging ports
- Built-in charging cables  
Android and Apple device 2.1A
- Bluetooth connectivity
- Hotel mode one-off alarm
- Snooze function
- Daylight saving feature

### Option

- Anti-theft cable



## HOMETIME ALARM CLOCK



REF HT HC2 PRO BK



### HOMETIME ALARM CLOCK

#### HT-HC2-PRO-BK

- Homtime Alarm Clock with dual charge function
- Black
- Dimmable LCD screen
- Auto-adjusting LCD by light sensor
- Gesture-control night light
- 2 front USB ports
- Easy alarm setting
- Back-up power 3xAAA rechargeable batteries (included)

## HOMTIME BLUETOOTH RADIO ALARM CLOCK



REF HT D8



### HOMTIME BLUETOOTH RADIO ALARM CLOCK

#### HT-D8

- Homtime Bluetooth Radio Alarm Clock
- Wireless & dual USB charging
- Black, dimmable LCD screen
- 2 back USB ports
- Easy alarm setting
- Music player
- Premium bass speaker
- IR remote controller (optional)
- Back-up power 3xAAA batteries (not included)

## HOMETIME WIRELESS MOBILE CHARGE PAD



REF HT Q1 BK

### HOMETIME WIRELESS MOBILE CHARGING PAD

#### HT-Q1-BK

- Black
- 2 front USB ports for smart charging

# DESK LIGHTING

## BEACON DESK LAMP



REF 8 66 1574-SIL  
BEACON Silver  
USB + Wireless  
Charging UPC 12



### PRODUCT HIGHLIGHTS

- Energy-saving LED
- With various lighting options • Wireless charging
- USB port

### SPECIFICATIONS

- Input: 100V-240V
- Output: 5V/2.4A, 7W
- Adaptor 5V included
- 1.0A USB port for charging
- 5W Wireless charging
- Energy saving 32 LEDs
- Lumens 500LM
- 35,000 hour LED lifespan
- Touch control
- Various lighting options: Cool White/ Warm White/ Warm light
- Brightness control
- Adjustable arm & lamp
- Non-slip base
- Aluminium alloy and ABS
- Weight 1Kg
- Dim. H450/W120/D200mm
- Arm dim. H420mm
- Lamp dim. L380mm



# EMERGENCY TORCHES

## BRILLIANCE



REF **8 66 1227**  
Brilliance torch  
Black with chrome  
UPC 20



AUTO ON AND OFF

### BRILLIANCE

- JVD proprietary design
- Specifically designed for hotels
- Size H190/W50/D60mm
- Smart switch system:
  - Lift torch from cradle to auto turn on
  - Drop into cradle and auto turn off
- Powerful 13 LED white light
- Energy saving LED
- Non-slip handle
- Operates on 3 x AA batteries

### Flashing night light

- Built-in option
- Load 2 x AAA to activate

# LUGGAGE RACKS

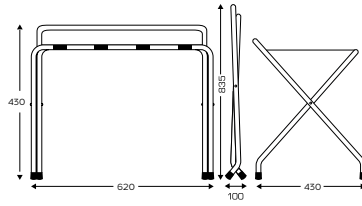

REF **TO-04507-C & TO-04507-BK**

Luggage rack with back bar  
 C: Chrome finish  
 Bk: Black finish  
 UPC 1

## SPECIFICATIONS

- Steel luggage rack
- Chrome or black finish
- Foldable
- With backbar
- 4 strengthening straps

## PREMIUM LUGGAGE RACK

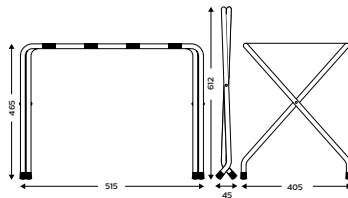

REF **8 66 1530**  
 Luggage rack  
 Steel, powder-coated black  
 UPC 4

## PREMIUM LUGGAGE RACK

### SPECIFICATIONS

- Steel luggage rack
- Powder-coated in black
- Foldable
- 4 brown leatherette straps





## Bathroom Fixtures & Accessories

# MIRRORS

Our mirrors are the result of a special alchemy melding innovation, performance and design. They invite guests to enjoy a unique experience with complete simplicity. The range of battery-operated mirrors are developed by our Design Department, specifically for use in hotel bathrooms.

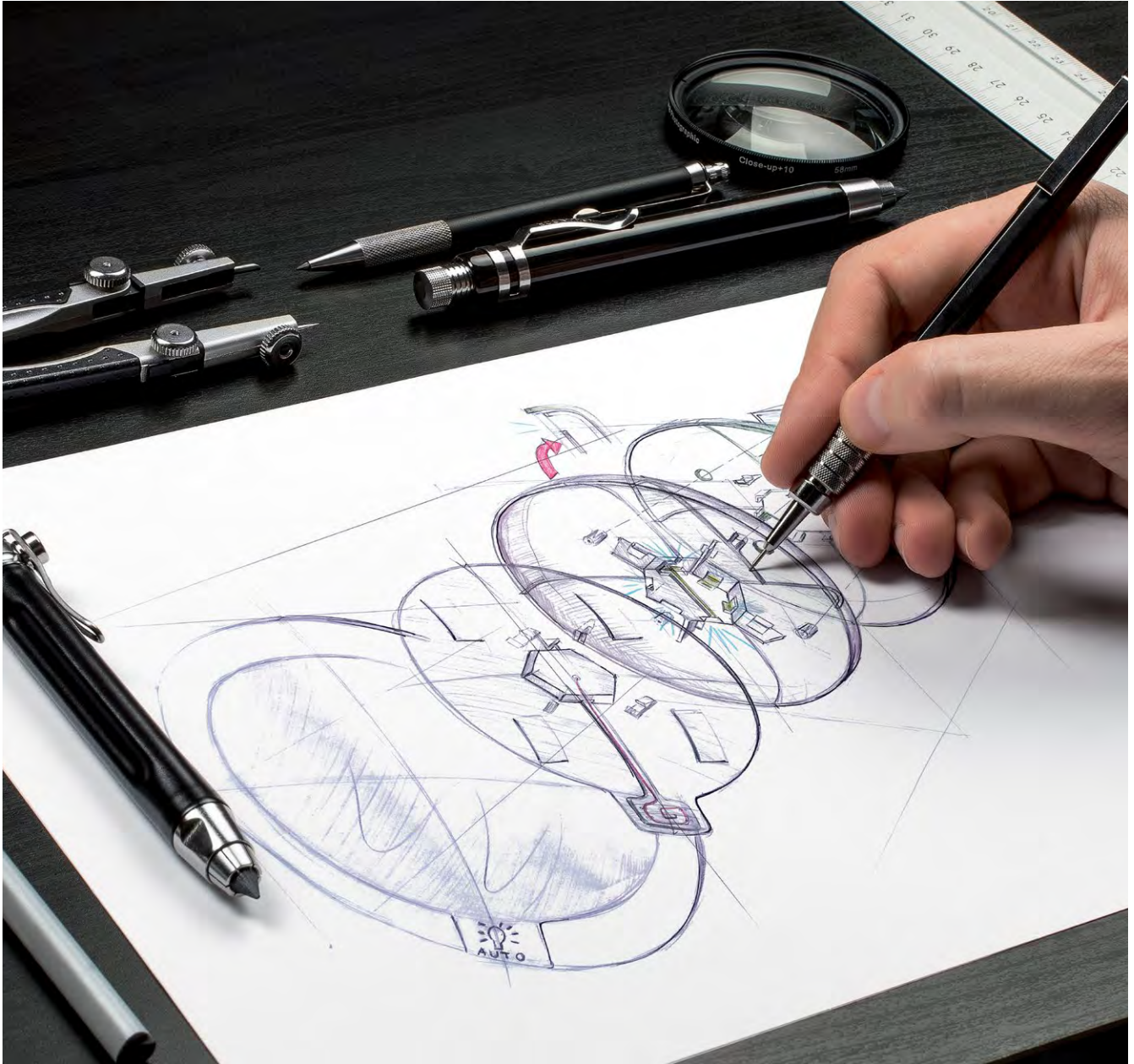

## NO ELECTRICAL CONNECTION REQUIRED

Our Cosmos mirrors run on a lithium battery and a 3 minute auto-off system ensuring longevity of 3 to 5 years.

Offering complete electrical safety, they can be installed in any area of the bathroom.

## TILTABLE TO ANY ANGLE

Thanks to their double or triple rotational axis, our mirrors offer your guests the best possible reflection.

## ECO-RESPONSIBLE

Our illuminated mirrors are fitted with LED lighting to maximize their lifespan without having to change the bulbs and to reduce their energy consumption.



# COSMOS ILLUMINATED MIRROR



REF **8 66 1136**  
Cosmos wall-mounted  
Brass chrome  
UPC 12



REF **8 66 1136-DT**  
Cosmos Desktop  
Brass chrome  
UPC 12



REF **8 66 1136-BK**  
Cosmos wall-mounted  
Brass, matt-black  
UPC 12



REF **8 66 1136-DT-BK**  
Cosmos desktop  
Brass, matt-black  
UPC 12

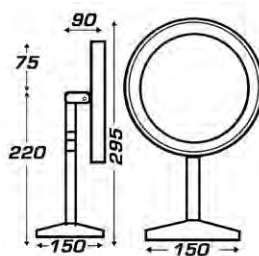
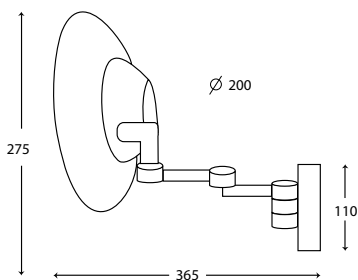

LED lighting all round the mirror



Magnifying reflection x5



No electrical connection required

### COSMOS

- Mirror size 200mm
- Magnification 5X
- Touch activation
- Cool white LED light
- Works on 3.6V lithium
- Battery life 3+ years
- 3 minutes auto-off
- Brass material
- Excellent rust resistant
- In chrome & matt-black



## FIESTA - WALL MOUNTED



REF **8 66 1510**  
Fiesta chrome  
UPC 12

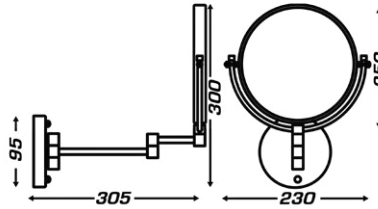

**SPECIAL  
\*ORDER\***

REF **8 66 1687**  
Fiesta Matt black  
UPC 12

## FIESTA - DESKTOP



REF **8 66 1514**  
Fiesta chrome  
UPC 12

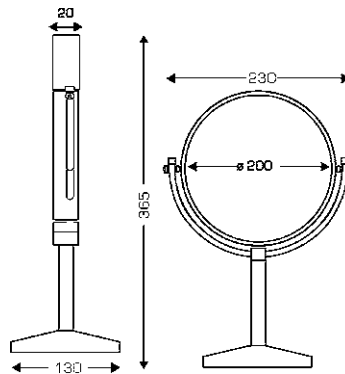

**SPECIAL  
\*ORDER\***

REF **8 66 1688**  
Fiesta Matt black  
UPC 12

### FIESTA WALL MOUNTED

- Wall-mounted
- Double side mirror
- Mirror size 200mm
- Normal & 3X magnification
- Brass arm & SS304 bracket
- Excellent rust resistant

### FIESTA DESKTOP

- Desktop
- Double side mirror
- Mirror size 200mm
- Normal & 3X magnification
- Brass arm & SS304 bracket
- Excellent rust resistant



## ARGO BLACK



REF **BFAB-3 00 861**  
Argo single towel  
rail UPC 24



REF **BFAB-3 00 862**  
Argo double towel  
rail UPC 21



REF **BFAB-3 00 863**  
Argo towel rack with  
rail UPC 10



REF **BFAB-3 00 864**  
Argo towel ring  
UPC 20



REF **BFAB-3 00 865**  
Argo single hook  
UPC 100



REF **BFAB-3 00 866**  
Argo double hook  
UP 100



REF **BFAB-3 00 867**  
Argo paper holder  
UPC 24



REF **BFAB-3 00 868**  
Argo brush holder  
UPC 10

### BFAB-300861

- Single towel rail
- SS304, powder-coated
- Matt black finishing
- H60/L577/D80mm

### BFAB-300862

- Double towel rail
- SS304, powder-coated
- Matt black finishing
- H60/L577/D120mm

### BFAB-300863

- Towel rack with rail
- SS304, powder-coated
- Matt black finishing
- H140/L577/D232mm

### BFAB-300864

- Towel ring
- SS304, powder-coated
- Matt black finishing
- H185/L180/D85mm

### BFAB-300865

- Single hook
- SS304, powder-coated
- Matt black finishing
- H50/L50/D80mm

### BFAB-3 00 866

- Double hook
- SS304, powder-coated
- Matt black finishing
- H50/L50/D80mm

### BFAB-300867

- Paper holder
- SS304, powder-coated
- Matt black finishing
- H125/L145/D85mm

### BFAB-300868

- Toilet brush holder
- SS304, powder-coated
- Matt black finishing
- H365/L160/D125mm



## BAMBOO STYLE COLLECTION



REF **RBS-300 721**  
Amenity Tray  
Bamboo finish  
UPC 10



REF **RBS-300 722**  
Tissue Box  
Bamboo finish  
UPC 10



REF **RBS-300 723**  
Soap Dish  
Bamboo finish  
UPC 40



REF **RBS-300 724**  
Amenity Drawer Box  
Bamboo finish  
UPC 4

### BATHROOM AMENITIES BAMBOO STYLE COLLECTION

- Resin material
- Water and rust resistant
- Bamboo style finishing
- RBS-300 721
- Amenity Tray
- Dimensions H20/L314/D133mm
- RBS-300 722
- Tissue Box
- Magnetic base cover
- Dimensions H150/L140/D140mm
- RBS-300 723
- Soap Dish
- Dimensions H25/L113/D113mm
- RBS-300 724
- Amenity Box
- With 3 compartments
- Dimensions H90/L275/D155mm



**WHITE MARBLE COLLECTION**



REF **RWM-300 706**  
Amenity Box, UPC 4

**BATHROOM AMENITIES RESIN, WHITE MARBLE**

- **RWM-3 00 706**
- Amenity Box
- With 3 compartments
- H90/L275/D155mm



REF **RWM-300 701**  
Amenity Tray, UPC 10

- **RWM-3 00 701**
- Amenity Tray
- H20/L310/D133mm



REF **RWM-300 703**  
Soap Dish, UPC 40

- **RWM-300 703**
- Soap Dish
- H22/L117/D83mm



REF **RWM-300 705**  
Condiment Holder, UPC 40

- **RWM-300 705**
- Condiment Holder
- H105/L80/D80mm



REF **RWM-300 702**  
Tissue Box, UPC 8

- **RWM-300 702**
- Tissue Box
- Magnetic top cover
- H150/L140/D140mm

**MATT BLACK COLLECTION**



REF **RMB-300 716**  
Amenity Box, UPC 4

**BATHROOM AMENITIES RESIN - MATT BLACK**

- **RMB-300 716**
- Amenity Box
- With 3 compartments
- H90/L275/D155mm



REF **RMB-300 711**  
Amenity Tray, UPC 10

- **RMB-300 711**
- Amenity Tray
- H20/L310/D134mm



REF **RMB-300 713**  
Soap Dish, UPC 40

- **RMB-300 713**
- Soap Dish
- H22/L117/D83mm



REF **RMB-300 715**  
Condiment Holder, UPC 40

- **RMB-300 715**
- Condiment Holder
- H105/L80/D80mm



REF **RMB-300 712**  
Tissue Box, UPC 8

- **RMB-300 712**
- Tissue Box
- Magnetic top cover
- H150/L140/D140mm

# SCALES

## ENVIE DIGITAL



REF **8 66 1525**  
ENVIE digital  
Non-slip platform  
UPC 8



REF **8 66 1526**  
ENVIE digital  
Non-slip platform  
UPC 8

### ENVIE DIGITAL

- Slim H16/275/275mm
- Non-slip platform
- 5mm thick
- KG/LB selector
- LCD display
- Capacity 180KG/396 LB
- Operates on 1 lithium
- Truffle Black or Pepper White

## ELCAT DIGITAL



REF **8 66 754**  
ECLAT digital  
UPC 5



REF **8 66 753**  
ECLAT digital  
UPC 5

### ELCAT DIGITAL

- Dim. H22/300/300mm
- KG/LB selector
- LCD display
- With backlight
- 8mm tempered glass
- Capacity 150KG/330 LB
- Operates on 2AAA

## DYNA BATTERY-FREE



REF **8 66 1527**  
DYNA digital  
Battery-free  
Black, UPC 5



REF **8 66 1563**  
DYNA digital  
Battery-free  
White, UPC 5



Battery-free  
One simple  
step  
Generate  
power  
Precision



### DYNA BATTERY-FREE

- Dim. H25/300/300 mm
- KG/LB selector
- LCD display
- Reinforced tempered glass
- 5mm thick
- Capacity 180KG/396 LB
- Battery-free system





## Guest Room Accessories

## ZEN LINE II



### ZEN LINE II

- High quality melamine trays
- Certified food grade
- Heat and stain resistant
- Fixable to JVD kettles
- 3 colors available

#### Dimensions:

Main Tray H25/W298/L377mm  
 Service Tray H10/W155/L295mm  
 Sachet Tray H49/W144/L215mm  
 Small Sachet H49/W115/L152mm

#### Compact Square Main Tray:

H25/W302/L302mm  
 Available only in Black color

White ○      Black ●

Zen Main Tray	4	REF 8 66 885	REF 8 66 891
Zen Main Tray with kettle fixation	4	REF 8 66 886	REF 8 66 892
Zen Service Tray	12	REF 8 66 887	REF 8 66 893
Zen Sachet Tray	6	REF 8 66 383	REF 8 66 393
Zen Small Sachet Tray	6	REF 8 66 384	REF 8 66 394
Zen Square Main Tray with kettle	4	NA	REF 8 66 892-M1



REF 8 66 892-M1



#### Kettle Fixation

Designed for fixation with JVD kettles; for aesthetics, convenience and anti-theft



## VOYAGER



White ○ Black ●

Voyager Main Tray	16	REF 8 66 163	REF 8 66 074
Voyager Service Tray	72	REF 8 66 164	REF 8 66 075
Voyager Sachet Tray	72	REF 8 66 165	REF 8 66 076

### VOYAGER

- High quality melamine trays
- Certified food grade
- Heat and stain resistant
- 3 colors available

### Dimensions:

Main Tray H25/W330/L400mm  
 Service Tray H17/W145/L315mm  
 Sachet Tray H50/W100/L100mm

## CHARME LEATHERETTE ACCESSORIES



REF 8 66 1018  
 Charme main tray  
 Black, UPC 12

REF 8 66 1020  
 Charme sachet tray  
 Black, UPC 54

### CHARME TRAYS

- Quality PU leatherette
- Main 8661018 : H32/L400/D290mm
- Sachet 8661020 : H63/L161/D83mm



## TISSUE BOXES



REF **8 99 960**  
Tissue box, black  
Melamine, UPC 24



REF **8 99 961**  
Tissue box, Ivory  
Melamine, UPC 24



REF **8 99 1035**  
Tissue box, black  
Leatherette, UPC 24



 REF **8 99 1037**  
Tissue box, black  
Leatherette, UPC 36

### TISSUE BOXES

- Ref: 899 960
- Square, melamine black
- H150/L138/D138mm
- Ref: 899 961
- Square, melamine ivory
- H150/L138/D138mm
- Ref: 899 1035
- Square, leatherette black
- H140/L128/D128mm
- Ref: 899 1037
- Rectangle, leatherette black
- H70/L128/D250mm

## ICE BUCKET



**SPECIAL  
\*ORDER\***

REF **8 99 1028**  
Ice bucket, single  
layer  
Letherette black,  
UPC 18

### ICE BUCKET

- Capacity 1 litre
- Internal stainless steel
- Include ice tong

Single Layer

- Ref: 8991028 : H180/  
W140mm
- Ref: 8991029 : H180/  
W140mm

## WARDROBE HANGERS



**"Timber Coat Hanger Male with notches & trouser rail  
Walnut - 440mm width x 14mm thick"  
S4S-H2630WE, UPC 100**



**"Timber Coat Hanger Female with notches & adjustable garment clips  
Walnut - 440mm width x 14mm thick"  
S4S-H2631WE, UPC 100**



**"Timber Coat Hanger Male with notches & trouser rail  
Beech - 440mm width x 14mm thick"  
S4S-H2630BH, UPC 100**



**"Timber Coat Hanger Female with notches & adjustable garment clips  
Beech - 440mm width x 14mm thick"  
S4S-H2631BH, UPC 100**



**"Timber Coat Hanger Female with notches & adjustable garment clips  
Black - 440mm width x 14mm thick"  
S4S-H2631BK, UPC 100**



**"Timber Coat Hanger Male with notches & trouser rail  
Black - 440mm width x 14mm thick"  
S4S-H2630BK, UPC 100**

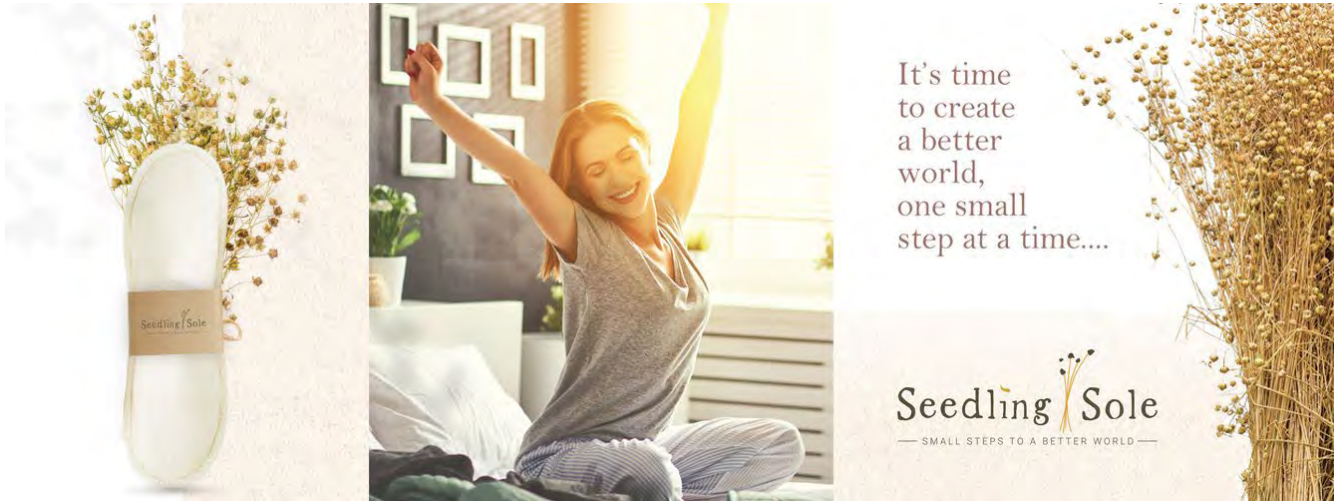

## Bio Slippers 'Seedling Sole'

Seedling Sole Biodegradable Hotel Slippers with Cork or Flax sole and unbleached linen upper material. 100% plastic-free, naturally compostable, 29cm, wheat colour, in environmental craft paper wrapper or envelope



**Seedling Sole Hotel Slippers, Open-Toe**  
with Cork sole, 29cm, in craft WRAPPER  
SSL-OTCS-WPR, UPC 100



**Seedling Sole Hotel Slippers, Closed-Toe**  
with double-Flax sole, 29cm, in craft ENVELOPE  
SSL-CTDF-ENV, UPC 100



**Seedling Sole Hotel Slippers, Closed-Toe**  
with double-Flax sole, 29cm, in WRAPPER  
SSL-CTDF-WPR, UPC 100

## Economy Slippers 'Slimline'



**Economy Hotel Slippers in Terry Cotton**  
**Towelling 'Slimline' - Open-toe.**  
3mm EVA sole, 28cm.  
SWS-STC-SLM-OT, UPC 100

## SINGLE LAYER & SWING TOP



REF **WBU-300 514**  
Swing-top, 8 litre  
Black, UPC 6

## FIRE RETARDANT BINS



REF **WBR-300 537**  
Fire-rated bin, 10  
litre  
Black, UPC 6

## ROUND - DOUBLE LAYER



REF **WBU-300 515**  
Round 10L Black  
PU leatherette,  
UPC 6

## RECTANGULAR DOUBLE LAYER



REF **WBU-300 523**  
Rectangle 7.6L  
Black, UPC 6



REF **WBU-300 524**  
Rectangle 7.6L  
Beige, UPC 6

### SWING-TOP

- Bin with swing top lid
- Anti-slip rubber lining at base
- 8L, H260/W200mm
- Powder coated black & SS finishing

### FR BINS

- 10 litre capacity
- Certified fire rated material
- Rust and scratch resistant
- Easy to wash and clean
- Black color
- Ref: **WBR-300 537**
- Anti-slip rubber lining at base
- 10L, H270/W225mm
- Ref: **WBR-300 539**
- 10L, H300/W228/D175mm

### ROUND DOUBLE LAYER

- Round metal bin
- 10 litre, with Inner metal bin liner
- With anti-slip rubber base
- Dimensions H270/W225mm
- Ref: **WBU-300 516**
- Powder-coated black
- Ref: **WBU-300 515**
- PU leatherette black

### RECTANGLE DOUBLE LAYER

- Rectangle metal bin
- 7.6 litre, with inner metal liner
- With anti-slip rubber base
- Powder-coated finishing
- Dimensions H275/L225/D165mm

## PLASTIC BINS



REF **WBU-300 526**  
Plastic bin, 10 litre  
Black, UPC 6

### PLASTIC BINS

- Durable plastic bin
- Impact and rust resistant
- With PVC wrap-around
- 10L, H285/W235/D155mm

## PEDAL BINS



PEDAL BIN  
SS MATT FINISH  
**WBF-300 332 /3L**  
**WBF-300 333 /5L**  
UPC 6

**WBF-300 335 /12L**  
UPC 4



Pedal bin  
SS matt black  
**WBF-300 332-MB/ 3L**  
**WBF-300 333-MB/ 5L**  
UPC 6

### PEDAL BINS SOFT-CLOSE

- Stainless steel material
- With soft-close lid
- Anti-slip rubber base
- Plastic liner included
- WBF-300 332/ 332-MB  
3L, H262/W171mm
- WBF-300 333/333-MB  
5L, H280/W205mm





## RECYCLE BINS - 10L/14L



REF **8 99 1229-ML-RCL**  
Recycle bin, 10 litre  
Metal + 2 plastic  
liners  
Black, UPC 6



REF **8 99 1261-ML-RCL**  
Recycle bin, 14 litre  
Metal + 2 plastic  
liners  
Black, UPC 6



### RECYCLE BINS

- Outer bin in steel
- Powder-coated in black
- Includes 2 inner plastic bins
- Easy to remove and clean
- Ref: 899 1229
- Round, 10 litre
- With anti-slip rubber base
- Dimensions H270/W225mm
- Ref: 899 1261
- Rectangle, 14 litre
- Dimensions H296/L270/D210mm

## COMMUNCAL BINS



REF **PB-3 00 420**  
COMMUNCAL  
Dustbin 30L, Nickel  
Black finish, UPC 1



REF **PB-3 00 423**  
COMMUNCAL  
Dustbin 28L, Matte  
S/S finish, UPC 2

### SPECIFICATIONS

- Decorative in-door use
- S/S bins with finger-print resistance
- Inner liner included
- Ref: **PB-300 420**  
Dim. H700/W320/D260mm
- Ref: **PB-300 423**  
Dim. H670/305mm Ø



**Lobby & Housekeeping**



## LUGGAGE CARTS



REF LCU-3 00 506  
LUGGAGE Truck  
Silver Chrome  
UPC 1



REF LCU-3 00 507  
LUGGAGE Truck  
Gold Chrome  
UPC 1



REF LCU-3 00 505  
LUGGAGE Cart  
Gold Chrome  
UPC 1



REF LCU-3 00 504  
LUGGAGE Cart  
Silver Chrome  
UPC 1

### SPECIFICATIONS

- Luggage Trucks
- Stainless steel 38mmØ tubing
- Durable double chroming
- Deck carpeted
- Rubber bumper all-round
- 8" solid cushion wheels
- 2 fixed & 2 swivel
- 250mm ground clearance
- Weight 34 Kg
- Maximum load 250Kg
- Dim. H900/L1050/W610mm
- Assembly required

### SPECIFICATIONS

- Luggage Carts
- Stainless steel titanium
- Strong 38mmØ tubing
- Durable double chroming
- Deck carpeted
- Rubber bumper all-round
- 8" pneumatic wheels
- 2 fixed & 2 swivel
- 250mm ground clearance
- Weight 40 Kg
- Maximum load 250Kg
- Dim. H1900/L1140/W670mm
- Assembly required

## HAND TRUCK



REF HTU-3 00 508  
HAND Truck  
Silver Chrome  
UPC 1



### SPECIFICATIONS

- Hand Truck
- Stainless steel 38mmØ tubing
- Durable double chroming
- Silver chroming with black carpet
- Foldable platform
- Carpet can be easily replaced
- Hanging hook
- 10" pneumatic wheels
- Weight 16.5 Kg
- Maximum load 200Kg
- Dim. H1220/L400/W500mm
- Assembly required



## BIRDCAGE TROLLEYS



REF **LCU-3 00 502**  
CLASSIC Birdcage  
Silver Chrome  
UPC 1



REF **LCU-3 00 503**  
CLASSIC Birdcage  
Gold Chrome  
UPC 1

### SPECIFICATIONS

- Classic Birdcage
- Stainless steel
- Strong 38mmØ tubing
- Durable double chroming
- Deck carpeted
- Rubber bumper all-round
- 8" solid wheels
- 2 fixed & 2 swivel
- 250mm ground clearance
- Weight 38 Kg
- Maximum load 250Kg
- Dim. H1860/L1050/W610mm
- Assembly required

## HOUSEKEEPING CARTS



REF **HCP-3 00 251-DR-BK**  
HOUSEKEEPING Cart  
Doors + Top Organizer  
+ Base Drawer  
UPC 1

### SPECIFICATIONS

- Made of strong polypropylene material (PP)
- Bags with carriers for easy lifting
- 8" special PP wheels, 2 fixed and 2 swivel
- 4 revolving corner bumper wheels
- Approx. Weight 60 Kgs
- Load capacity up to 150 Kg
- Black color
- Dim. H1280 /L1560/ W540mm
- Assembly required

### FITTED WITH

- Removable metal top organizer
- 2 full bags with high quality zippers
- Lockable metal base drawer
- 1 fixed shelf as standard

Optional :  
- Lockable double-leaf doors (HCP-300251-DR-BK)

## MINIBAR RESTOCKING CART



REF **MRC-3 00 252-AG**  
Minibar Refill Cart  
UPC 1

### SPECIFICATIONS

- Minibar Refill Cart
- Metal construction
- Epoxy power-coated
- With lockable top organizer
- 2 handles for easy manoeuvrability
- 3 adjustable pull-out roller shelves
- 8" solid wheels:
- 2 fixed and 2 swivel with brakes
- 4 x 4" revolving corner bumper wheels
- Weight approx. 85 Kg
- Load capacity 54 cans per shelf
- Anthracite grey finishing
- Dim. H1310/L940/W535mm
- Assembly required

### FITTED WITH

- Lockable top organizer with handle
- 3 adjustable pull-out roller shelves
- Lockable double-leaf doors
- \* All locks are with key-alike system



## LINEN & LAUNDRY TROLLEYS



REF LTW-3 00 549  
LINEN Trolley,  
UPC 1



REF LTW-3 00 545  
LINEN Trolley,  
UPC 1



REF LTW-3 00 546  
X'cart, UPC 1



REF LTW-3 00 544  
X'cart, UPC 1



REF LT-3 00 236  
LAUNDRY Trolley,  
UPC 1



REF LT-3 00 237  
LAUNDRY Trolley,  
UPC 1

### SPECIFICATIONS

- Strong metal tube 25mm Ø
- Rust resistant
- 4" solid swivel wheels
- 4 revolving corner wheels
- Bag included
- Assembly required

- REF: **LTW-300 549**  
Black tubing with Black bag  
Overall Dim. H930/L940/W685mm  
Approx. weight 14.4 Kg

- REF: **LTW-300 545**  
Black tubing with Khaki bag  
Overall Dim. H930/L1005/W640mm  
Approx. weight 13.8 Kg

- REF: **LTW-300 546**  
Chrome tubing with Black bag  
Overall Dim. H980/L890/W670mm  
Approx. weight 11 Kg

- REF: **LTW-300 544**  
Black tubing with Khaki bag  
Overall Dim. H980/L890/W670mm  
Approx. weight 11 Kg

### SPECIFICATIONS

- Stainless steel 201 grade
- Rust resistant
- 4" swivel wheels with brakes
- Assembly required

- REF: **LT-300 236**  
Overall Dim. H1710/L1200/D580mm  
Approx. Weight 7.8 Kgs

- REF: **LT-300 237**  
Overall Dim. H1510/L1090/D500mm  
Approx. Weight 27.7 Kgs

## MULTIPURPOSE HOUSEKEEPING & CLEANING TROLLEY



REF LT-3 00 220  
MULTI-purpose  
Trolley, UPC 1



REF LT-3 00 229  
ORGANISER, UPC 1

### SPECIFICATIONS

- Multi-purpose Trolley
- Lightweight
- Strong polypropylene material
- Resists rust, chips and dents
- Multi-purpose usage
- Quiet, non-marking wheels
- Vinyl bag included
- Dim. H990/L1110/W505mm
- Approx. Weight 12 Kgs
- Assembly required



# Hotel Project Services

Whether you are looking to renovate, update or build from scratch, our experienced project team can assist you in the planning of your project - large or small.

Operating Equipment, Fixtures and Fittings are now an integral part of the guest experience you offer, so best to plan in advance and let one of our experts assist you in the process.

Here is how we can help:



## Project Planning

Understanding our clients' expectations is key to success, hence we spend much time understanding your vision and objectives before we start.



## Costing

Together, we tailor a commercial framework to accommodate your budget. Generally speaking, we can offer a 'good, better, best' option in every category for you to choose from.



## Product Scheduling

We take the administrative hassle out of your day, so you can focus on what you are good at - planning the opening of your new hotel or motel in the near future.



## Guest Experience

In everything we do, we place your guest at the centre of all our actions and decisions, to deliver the best possible experience they could imagine.



## Industry Expertise

Based on over 20 years of experience, we have an abundance of experience to share, helping you prevent the pitfalls and maximising your dollar in the interest of your guest.



## Operator Reality

Like you, we are hoteliers and hosts at heart. Understanding the operational challenges you face, puts us in the best position to ensure these are dealt with at the outset.



## Design

With a keen eye for detail, we ensure your new operating equipment ties in beautifully with the overall design intent without compromise of functionality.



## The Edge

With an abundance of choice, we tailor your fit-out to give you a competitive edge in a crowded market.



## After Sales

Replacements are unavoidable in a busy environment, hence all our products and brands come with a piece-of-mind replacement warranty.



## Customer Service

During and after our collaboration, we ensure seamless dialogue and transparency and guarantee we will see you through to the date of delivery.

# Let's Talk

## 02 9979 1500

If you are planning a renovation or a new-build, we are here to help. Contact us today for an obligation-free discussion of your plans and requirements.



# Your 360° Hospitality Lifestyle Professionals

## Sales Office

Swisstrade Pty Ltd  
PO Box 553  
Newport Beach NSW 2016

T: 02 9979 1500  
F: 02 9979 2555  
E: [enquiries@swisstrade.com.au](mailto:enquiries@swisstrade.com.au)  
W: [swisstrade.com.au](http://swisstrade.com.au)



That's our hospitality, that's Swisstrade..

**At your advantage**