

Repair/Parts



MODEL MVP-150XL VAPOR RECOVERY PUMP

3A7034A
EN

Designed for hydrocarbon extraction processing.

For LP-Gas Recovery

Electric-Powered

Dual-Diaphragm

Hazardous Location Motor

Stainless Steel Wetted Parts

Rated MAWP: LPG-375-PSI

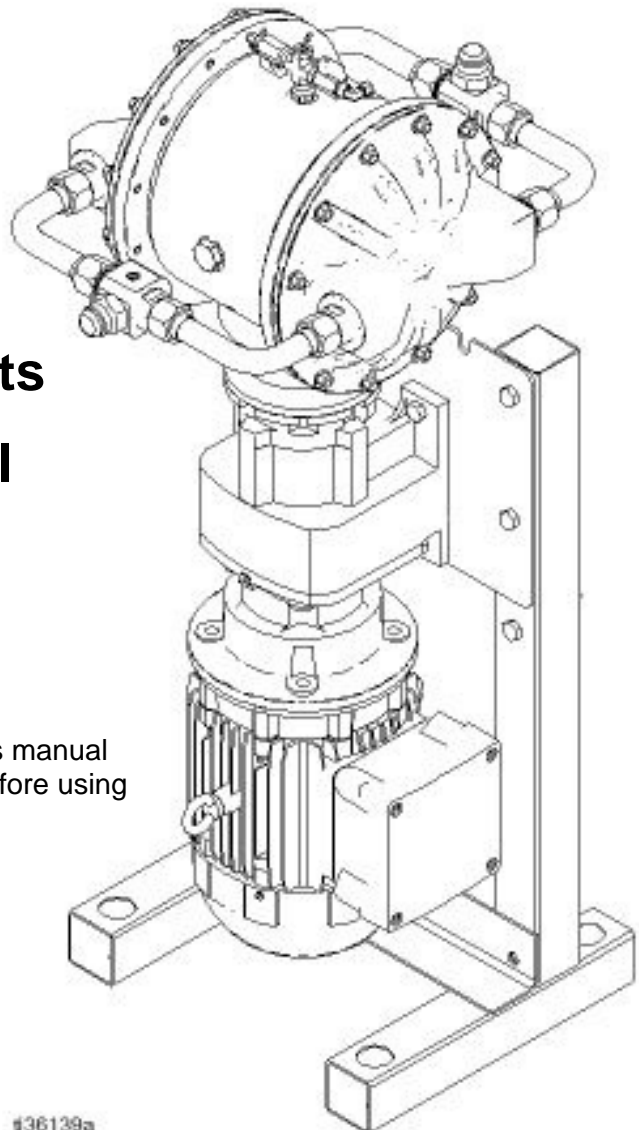

For professional use only.



Important Safety Instructions

Read all warnings and instructions in this manual and in the pump Repair/Parts manual before using the equipment.

Save these instructions.

Contents

Models.....	2	Check Valve Repair	8
Related Manuals	2	Diaphragm Repair.....	9
Approvals.....	2	Center Section Repair	11
Warnings	3	Torque Instructions	15
Troubleshooting.....	6	Parts.....	17
Repair.....	7	Technical Data	21
Pressure Relief Procedure.....	7	MVP Standard Warranty	22



Models

Part Number	Model	Includes:		
		Motor	Pump	CO ₂ Cylinder
25M869	MVP-150XL	5 HP	yes	no

Related Manuals







Manual Number	Title
3A6887	Model MVP-150XL Vapor Recovery Pump, Operation









Approvals





Approvals	
Motors on pump model 25M869 certified to:	 Class I – Div. I – Group C and D, T3C
	 Class I – Div. I – Group C and D, T3C Class II – Div. I – Group F and G, T3C

Warnings

The following warnings are for the setup, use, grounding, maintenance, and repair of this equipment. The exclamation point symbol alerts you to a general warning and the hazard symbols refer to procedure-specific risks. When these symbols appear in the body of this manual or on warning labels, refer back to these Warnings. Product-specific hazard symbols and warnings not covered in this section may appear throughout the body of this manual where applicable.

 DANGER	
	<p>SEVERE ELECTRIC SHOCK HAZARD</p> <p>This equipment can be powered by more than 240 V. Contact with this voltage will cause death or serious injury.</p> <ul style="list-style-type: none"> • Turn off and disconnect power at main switch before disconnecting any cables and before servicing equipment. • This equipment must be grounded. Connect only to grounded power source. • All electrical wiring must be done by a qualified electrician and comply with all local codes and regulations.
 WARNING	
   	<p>FIRE AND EXPLOSION HAZARD</p> <p>Flammable fumes in work area can ignite or explode. Vapor or solvent flowing through the equipment can cause static sparking. To help prevent fire and explosion:</p> <ul style="list-style-type: none"> • Use equipment only in well ventilated area. • Eliminate all ignition sources; such as pilot lights, cigarettes, portable electric lamps, and plastic drop cloths (potential static arc). • Ground all equipment in the work area. See Grounding instructions. • Keep work area free of debris, including solvent, rags and gasoline. • Do not plug or unplug power cords, or turn power or light switches on or off when flammable fumes are present. • Stop operation immediately if static sparking occurs or you feel a shock. Do not use equipment until you identify and correct the problem. • Keep a working fire extinguisher in the work area.

 <h1 style="margin: 0;">WARNING</h1>	
  	<p>PRESSURIZED EQUIPMENT HAZARD</p> <p>Vapor or solvent from the equipment, leaks, or ruptured components can splash in the eyes or on skin and cause serious injury.</p> <ul style="list-style-type: none"> • Follow the Pressure Relief Procedure when you stop operation and before cleaning, checking, or servicing equipment. • Tighten all hose and pressure connections before operating the equipment. • Check hoses, tubes, and couplings daily. Replace worn or damaged parts immediately.
 	<p>EQUIPMENT MISUSE HAZARD</p> <p>Misuse can cause death or serious injury.</p> <ul style="list-style-type: none"> • Do not operate the unit when fatigued or under the influence of drugs or alcohol. • Do not exceed the maximum working pressure or temperature rating of the lowest rated system component. See Technical Data in all equipment manuals. • Use solvents that are compatible with equipment wetted parts. See Technical Data in all equipment manuals. Read solvent manufacturer's warnings. For complete information about your material, request Safety Data Sheet (SDS) from distributor or retailer. • Turn off all equipment and follow the Pressure Relief Procedure when equipment is not in use. • Check equipment daily. Repair or replace worn or damaged parts immediately with genuine manufacturer's replacement parts only. • Do not alter or modify equipment. Alterations or modifications may void agency approvals and create safety hazards. • Make sure all equipment is rated and approved for the environment in which you are using it. • Use equipment only for its intended purpose. Call your distributor for information. • Route hoses and cables away from traffic areas, sharp edges, moving parts, and hot surfaces. • Do not kink or over bend hoses or use hoses to pull equipment. • Keep children and animals away from work area. • Comply with all applicable safety regulations.
  	<p>THERMAL EXPANSION HAZARD</p> <p>Liquids subjected to heat in confined spaces, especially in hoses and pipes, can create a rapid rise in pressure due to the thermal expansion. Over-pressurization can result in equipment rupture and serious injury.</p> <ul style="list-style-type: none"> • All hoses and pipes possibly exposed to liquid LP-Gas must be fitted with proper hydrostatic relief valves to prevent over-pressurization. • Replace hoses proactively at regular intervals based on your operating conditions.

 WARNING	
	<p>LP-GAS HAZARD</p> <p>LP-Gas can cause serious injury or death if splashed in the eyes or on skin, inhaled, or ignited.</p> <ul style="list-style-type: none">• Read Safety Data Sheet (SDS) to know the specific hazards of the solvents you are using.• Store hazardous solvent in approved containers, and dispose of it according to applicable guidelines.
	<p>BURN HAZARD</p> <p>Equipment surfaces can become very hot during operation. To avoid severe burns:</p> <ul style="list-style-type: none">• Do not touch hot equipment.
	<p>PERSONAL PROTECTIVE EQUIPMENT</p> <p>Wear appropriate protective equipment when in the work area to help prevent serious injury, including eye injury, hearing loss, inhalation of fumes, and burns. This protective equipment includes but is not limited to:</p> <ul style="list-style-type: none">• Protective eyewear, and hearing protection.• Respirators, protective clothing, and gloves as recommended by the solvent manufacturer.



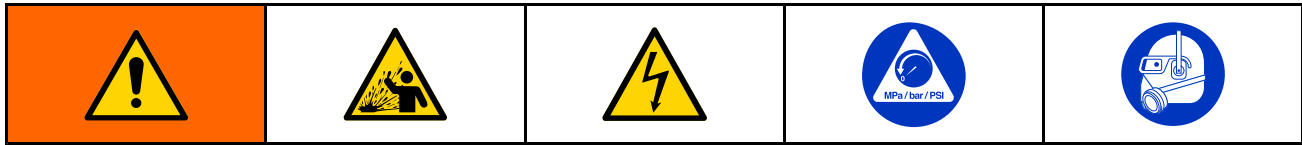

Troubleshooting



- Follow the [Pressure Relief Procedure, page 7](#) , before checking or servicing the equipment.
- Check all possible problems and causes before disassembly.

Problem	Cause	Solution
Pump cycles but will not prime and/or pump.	Pump head center section has no CO ₂ pressure, or CO ₂ pressure is too low.	Check CO ₂ supply, adjust CO ₂ to 150 psi.
	Check valves are worn or damaged.	Replace the check valves.
	Inlet or outlet hose is shut off.	Remove the restriction.
The center section is excessively hot.	The drive shaft is broken.	Replace.
Motor will not run.	Motor or controller is wired improperly.	Wire per manual.
	No power to motor.	Check electrical circuit.
The motor is operating, but the pump will not cycle.	The jaw coupling between the motor and gearbox is not connected properly.	Check the motor coupling.
Pump flow rate is erratic.	Inlet or outlet hose is pinched.	Inspect hoses.
	Check valves are sticky or bent.	Clean or replace check valves.
	Diaphragm ruptured.	Replace diaphragms.
CO ₂ consumption is higher than expected.	CO ₂ fitting is loose or hose damaged.	Inspect CO ₂ fittings and hoses.
	Loose or damaged o-rings or shaft seal in center section.	Rebuild center section.
	Diaphragm ruptured.	Replace diaphragms.
Pump leaks externally from joints.	Loose diaphragm cover screws or fittings.	Check screws and fittings for tightness.





Repair

				
<p>To avoid serious injury or death from fumes or fluids, never move or lift a pump under pressure. If dropped, the center section may rupture. Always follow the Pressure Relief Procedure, page 7, before moving or lifting the pump.</p>				

Pressure Relief Procedure



Follow the Pressure Relief Procedure whenever you see this symbol.





				
<p>This equipment stays pressurized until pressure is relieved manually. To help prevent serious injury from pressurized vapor, follow the Pressure Relief Procedure when you stop pumping for an extended period of time, and before you clean, check, or service the equipment.</p>				

1. Remove electric power from the system.
2. Vent all LP-Gas vapor from the pump and hoses according to extractor system instructions.
3. Close the shutoff valve on the CO₂ cylinder.
4. On CO₂ port (E), open the pump CO₂ bleed valve and CO₂ supply valve.

NOTE: In the event of a diaphragm rupture, LP-Gas may be present in the pump center section. Always vent all LP-Gas according to extractor system instructions.

5. If performing repairs, remove CO₂ regulator and tank from the pump prior to performing the work.

Check Valve Repair

				
<p>Manifold tubing may become hot during operation. Prior to removal, ensure that tubing has cooled enough to handle safely.</p>				

1. Follow the [Pressure Relief Procedure, page 7](#). Remove power from the motor. Disconnect all hoses.
2. Remove manifold tubing (14).

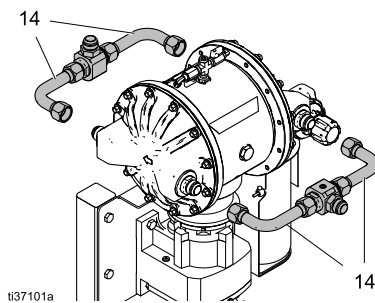



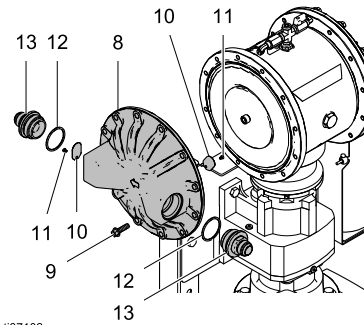

3. Remove outlet fitting from the diaphragm cover. Inspect the o-ring on the fitting for damage. Replace if needed.

4. Use a screwdriver to remove the outlet check valve screw.



5. Inspect the valve screw for damage. Replace if needed. Clean the outlet valve area and install the new check valve.
6. To repair the inlet check valve, the diaphragm cover must be removed. Use a 13 mm socket wrench to remove the 12 diaphragm cover screws and the diaphragm cover.
7. Use a screwdriver to remove the inlet check valve screw.
8. Inspect the valve screw for damage. Replace if needed. Clean the inlet valve area and install the new check valve.
9. Install the diaphragm cover and loosely install the 12 screws (9).
10. Torque the diaphragm cover screws as described in [Torque Instructions, page 15](#)
11. Repeat steps 2-10 for other side of the pump.
12. Restore all manifold tubing.

Diaphragm Repair

				
<p>Manifold tubing may become hot during operation. Prior to removal, ensure that tubing has cooled enough to handle safely.</p>				

Disassemble the Diaphragms

NOTE: Diaphragm kit is available. See Parts section.

1. Follow the [Pressure Relief Procedure, page 7](#). Remove power from the motor. Disconnect all hoses.
2. Remove the manifold tubing (14).
3. Use a 13 mm socket wrench to remove the 12 screws (9) from the diaphragm covers (8), then pull the covers off of the pump.
4. To remove the diaphragms, the piston must be moved fully to the side toward the diaphragm to be removed. If the pump is not attached to the motor, turn the shaft by hand to move the piston. If the pump is still attached to the motor, loosen the screws and remove the motor fan cover. Turn the fan by hand in one direction to rotate the shaft to shift the piston to one side.
5. Hold a 28 mm wrench on the wrench flats of the exposed piston shaft. Use another wrench (10 mm hex key) on the shaft bolt to remove it. Then remove all parts of the diaphragm assembly.
6. Rotate the drive shaft to move the piston fully to the opposite side, as described in step 4. Then remove the other diaphragm assembly.
7. To continue with disassembly, see [Disassemble the Center Section, page 11](#).

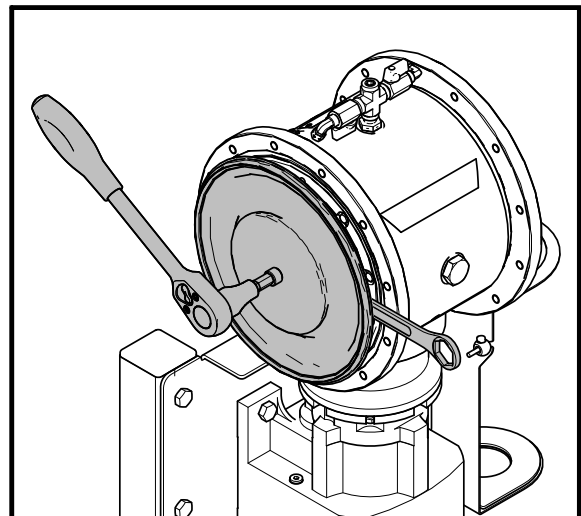
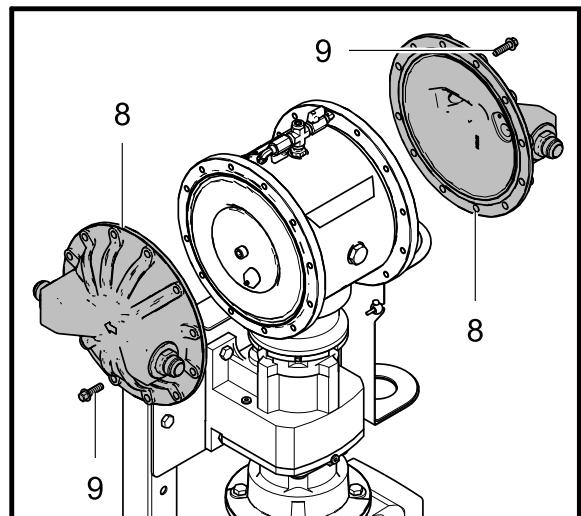
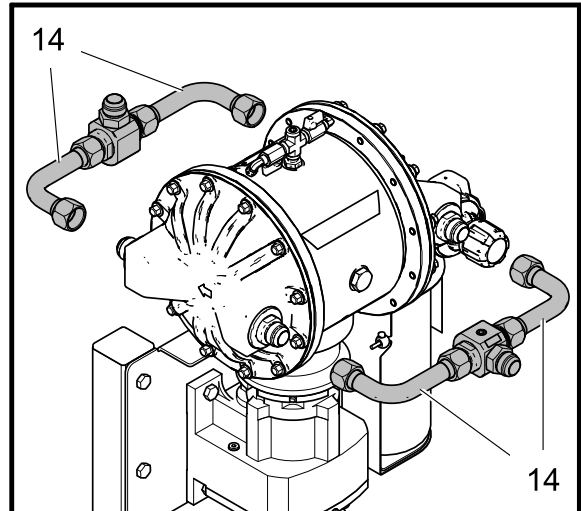

ti37103a

Reassemble the Diaphragms

TIP: If you are also repairing or servicing the center section (drive shaft, piston, etc.), see [Center Section Repair, page 11](#), before you put the diaphragms back on.

1. Clean all parts and inspect for wear or damage. Replace parts as needed. Be sure the center section is clean and dry.
2. Thoroughly clean or replace the piston shaft bolt (7). Install the o-ring (6).
3. Assemble the vapor side plate (5), the diaphragms (3, 4), and the CO₂ side diaphragm plate (2) on the bolt exactly as shown.
4. Clean the female threads of the piston shaft with a wire brush dipped in solvent to remove any residual thread locker. Apply thread-locking primer and allow it to dry.
5. Apply medium-strength (blue) thread locker to the threads of the bolt.
6. Rotate the drive shaft to move the piston fully to one side. See instructions in step 4 of [Disassemble the Diaphragms, page 9](#).
7. On the side where the shaft extends outward the farthest from the center section, hold a 28 mm wrench on the wrench flats of the piston shaft. Screw the bolt onto the shaft and torque to 100 ft-lb (135 N•m).
8. Repeat to install the other diaphragm assembly.

9. Attach the diaphragm covers and vapor caps. Apply medium-strength (blue) thread locker to the screw threads. See [Torque Instructions, page 15](#), to tighten.

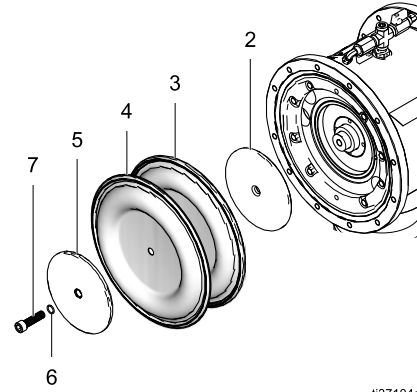

t137104a

NOTICE

- After reassembly, allow the thread locker to cure for 12 hours, or according to manufacturer's instructions, prior to operating the pump. Damage to the pump will occur if the diaphragm shaft bolt loosens.
- Apply anti-seize to threads on stainless steel fittings used on the manifold tubes.

10. Attach all manifold tubing.

Center Section Repair

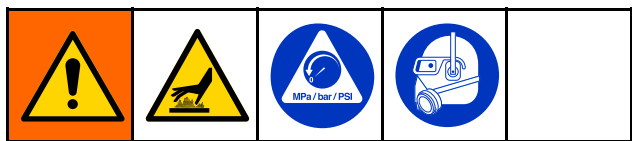

Disassemble the Center Section

See the illustrations on page 18.

1. Follow the [Pressure Relief Procedure, page 7](#) . Remove power from the motor. Disconnect all hoses.
2. Remove the manifolds.
3. Remove the covers and diaphragms as directed in [Disassemble the Diaphragms, page 9](#) .

TIP: Remove pump from stand and secure gearbox to bench. Leave the pump connected to the motor.

4. Remove the drive shaft:
 - a. Use a 10 mm (M8) hex wrench to remove 4 bolts (117). Pull the pump off of the alignment housing (116).

TIP: It may be necessary to tap the pump with a rubber mallet to disengage the coupler.

 - b. Remove CO₂ inlet fittings. Use a 30 mm socket wrench to remove the bearing bolt (106) and the o-ring (108).
 - c. Turn the shaft so the groove on the shaft is in line with the alignment markings on the center section.
 - d. Use a 3/4–16 bolt to push out the drive shaft assembly (112). You can also use the bearing bolt (106), but remove the bearing (107) first. Be sure that the groove on the drive shaft remains aligned with the markings in the center section.

NOTICE

Proper alignment is essential. Do not apply more than about 10 in-lb (1.1 N•m) of torque. Excessive torque could strip the housing thread. If you encounter resistance, check alignment or contact your distributor.

- e. The shaft coupler (113) might come out with the drive shaft assembly. If not, reach into the alignment housing (116) and remove the shaft coupler (113).
 - f. Remove the seal cartridge, o-ring (109) and the radial seal (111) with o-ring (111a) from the drive shaft assembly.
5. Slide the piston assembly (102) out of the center.

Reassemble the Center Section

1. Clean and dry the center housing (101), the center of the piston (105) and the drive shaft (109).
2. Inspect the piston for excessive wear and replace if needed. Grease the piston as shown and install it in the center section with the groove in line with the alignment markings on the center section.
3. Install the o-ring (113) and the bearing bolt (114). Apply medium-strength (blue) thread locker and torque the bolt to 15–25 ft-lb (20–34 N•m). Be sure that the bearing (112) is in the groove on the piston, as shown. Be sure that the piston moves freely.

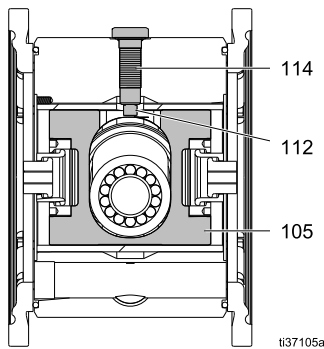

4. Install the drive shaft:
 - a. Be sure the sealing surface of the drive shaft (109) is clean. Install the seal cartridge and radial seal (107) on the drive shaft. The lips on the radial seal (107) must face **IN** toward the center.

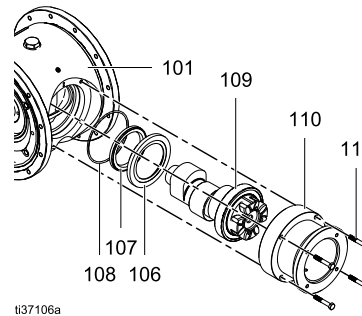

- b. Install o-ring (108) to the center housing (101).
 - c. Apply anti-seize lubricant on the mating edges of the drive shaft, as shown in the illustration, page 18.
 - d. Center the piston in the housing and install the drive shaft assembly (109) into the center housing (101) with the groove facing up.
 - e. Inspect the shaft coupler (115) for wear and replace if needed. Install on the drive shaft.
5. Be sure the gearbox coupler (11x) is aligned properly. Turn by hand if needed. Connect the pump to the gearbox assembly, engaging the couplers.
6. Apply medium-strength (blue) thread locker and install the housing screws (111). Tighten about 5 turns at a time, in a crisscross pattern, to fully engage the coupler. Torque to 130–160 in-lb (15–18 N•m).
7. Install CO₂ inlet fittings.
8. See [Reassemble the Diaphragms, page 10](#), and [Check Valve Repair, page 8](#).

- 1 Apply medium-strength (blue) thread locker to threads.
- 2 Torque to 15–25 ft-lb (20–34 N•m).
- 3 Lips must face **IN** toward the center.
- 4 Apply anti-seize lubricant liberally on the radial surfaces of the drive shaft assembly.
- 5 Install the drive shaft assembly with the groove facing up.
- 6 Tighten screws in a crisscross pattern, 5 turns at a time, to engage the coupler evenly. Torque to 130–160 in-lb (15–18 N•m).
- 7 Apply lubricant to inner mating surface.

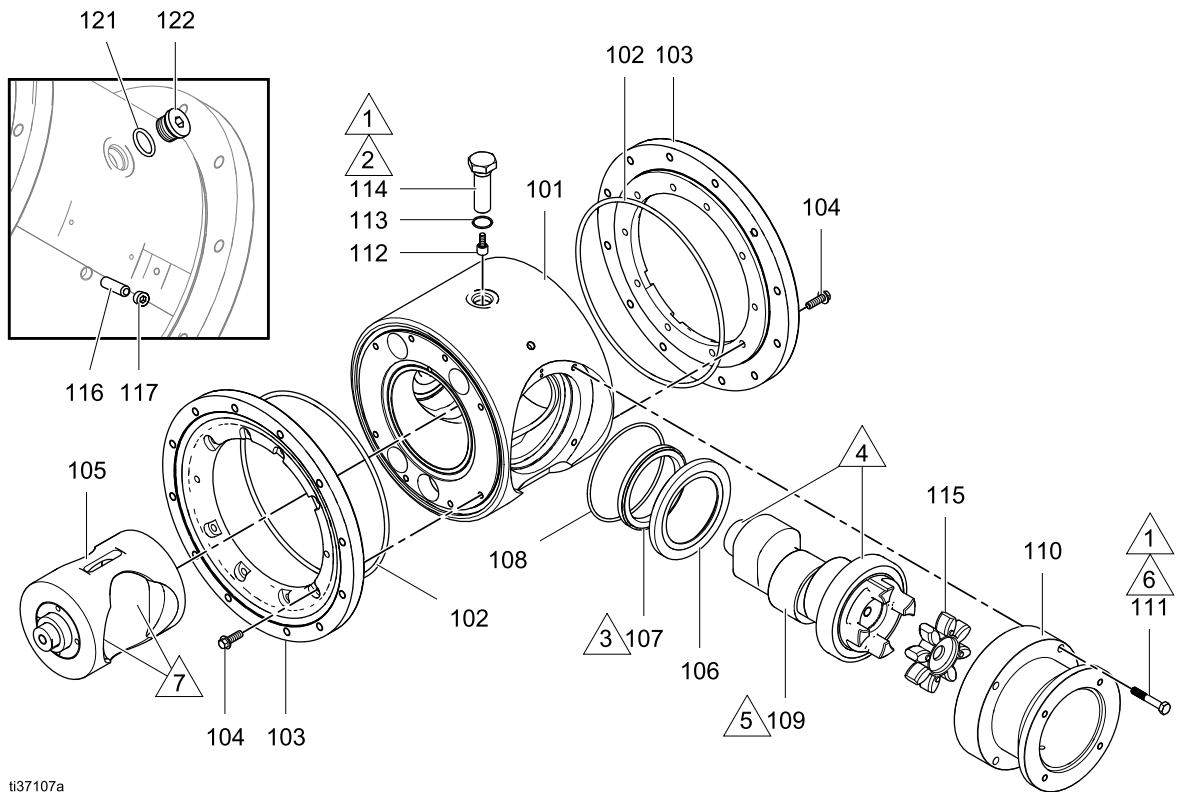

ti37107a

Disconnect the Motor and Gearbox

NOTE: Normally, the motor remains connected to the gearbox. Disconnect the motor only if you suspect that the motor or gearbox must be replaced.

1. Remove the pump from the stand.
2. Use a 3/4 in. socket wrench to remove 4 screws (130b).
3. Pull the motor (130d) straight off of the gearbox (130a).
4. Use a 3/4 in. socket wrench to remove 4 screws (116). Pull the gearbox off of the alignment housing.

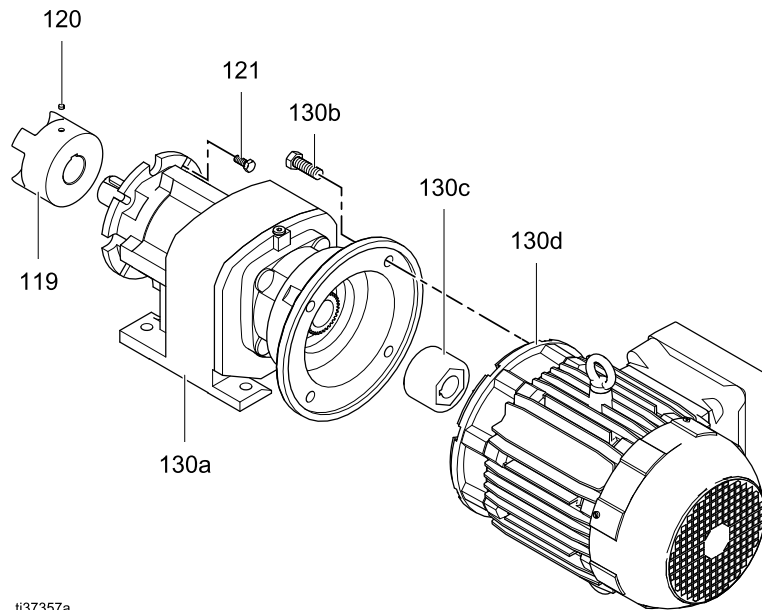

Torque Instructions

If diaphragm cover or vapor cap fasteners have been loosened, it is important to torque them using the following procedure to improve sealing.

NOTE: Cover and cap screws have a thread-locking adhesive patch applied to the threads. If this patch is excessively worn, the screws may loosen during operation. Replace screws with new ones or apply medium-strength (blue) thread locker to the threads.

NOTE: Always completely torque covers and caps before tightening manifolds.

1. Start all screws a few turns. Then, turn down each screw just until head contacts cover.
2. Turn each screw by 1/2 turn or less working in a crisscross pattern in the order shown to specified torque.

Diaphragm covers and vapor cap screws: 90 in-lb (10.2 N•m)

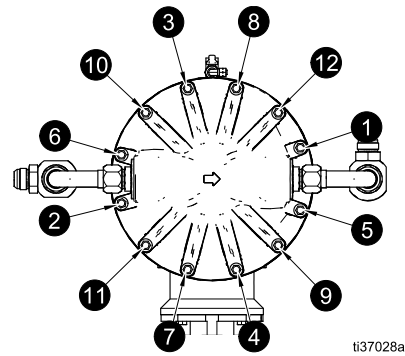

Parts

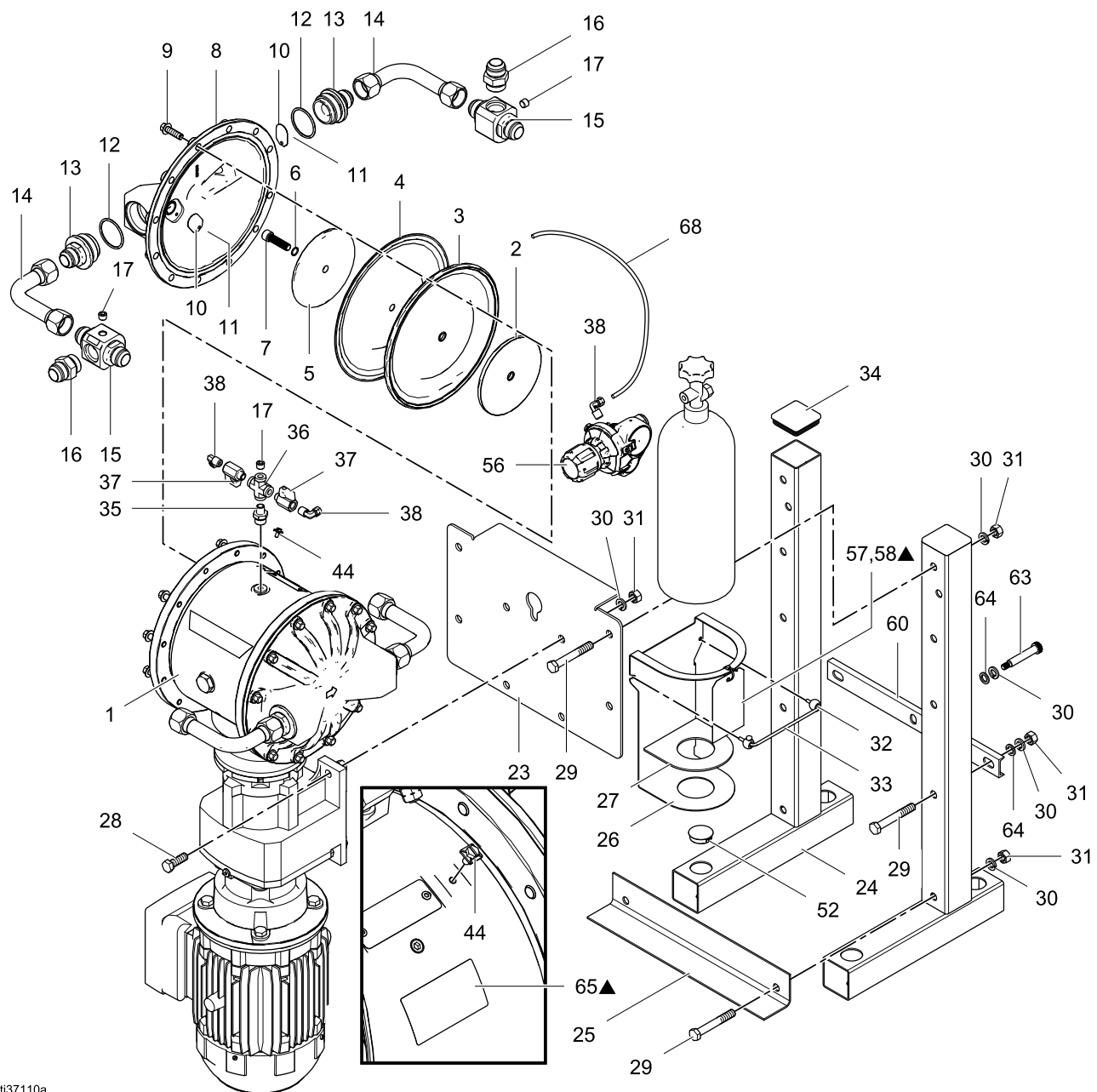

t37110a

Parts/Kits Quick Reference

Use this table as a quick reference for kits. Go to the kit table on page 20 for a full description of kit contents.

Ref.	Kit Ref	Description	Qty.
1	— — —	MODULE, drive; <i>See page 19.</i>	1
2	— — —	PLATE, CO ₂ side	2
3	207 208	DIAPHRAGM	2
4	207	DIAPHRAGM, backer	2
5	— — —	PLATE, vapor side	2
6	207 208	O-RING, for diaphragm shaft bolt	2
7	207 208	BOLT, shaft	2
8	217	DIAPHRAGM COVER, SST	2
9	217	SCREWS, cover, M8 x 1.25 x 25 mm	24
10	216 217	CHECK VALVE, reed	4
11	216 217	SCREW	4
12	216 217	O-RING	4
13	215	FITTING, adapter	4
14	215	TUBE, manifold	4
15	215	FITTING, JIC x 3/4	2
16	215	FITTING, adapter	2
17	215 221	PLUG	3
23	220	BRACKET	1
24	219	FRAME, leg	2
25	219	BRACE, frame	1
26	223	BRACKET, cylinder	1
27	223	PAD, cylinder (not shown)	1
28	214	BOLT, 1/2 x 1.5	4

Ref.	Kit Ref	Description	Qty.
29	219 220	SCREW	9
30	219 220	WASHER, lock	13
31	219	NUT	13
32	— — —	CLAMP, ball, cord lock	2
33	— — —	CORD	1
34	219 220	PLUG	6
35	221	FITTING, adapter	1
36	221	CROSS, pipe	1
37	221	VALVE, ball	2
38	218 221	FITTING, elbow, 1/4 tee x 1/4 npt	3
44	— — —	SCREW, ground, M5 x 0.8	1
52	219	PLUG	4
56	218	REGULATOR, CO ₂	1
58▲		LABEL, notice	1
60		BRACE	1
61		WASHER, flat, 5/16	1
62		WASHER, lock	1
63		SCREW, cap, 3/8-16	1
64		WASHER	2
65▲		LABEL, safety	1
68		HOSE, air	AR

— — — *Not sold separately.*

▲ Replacement safety labels, signs, tags, and cards are available at no cost.

Drive Section

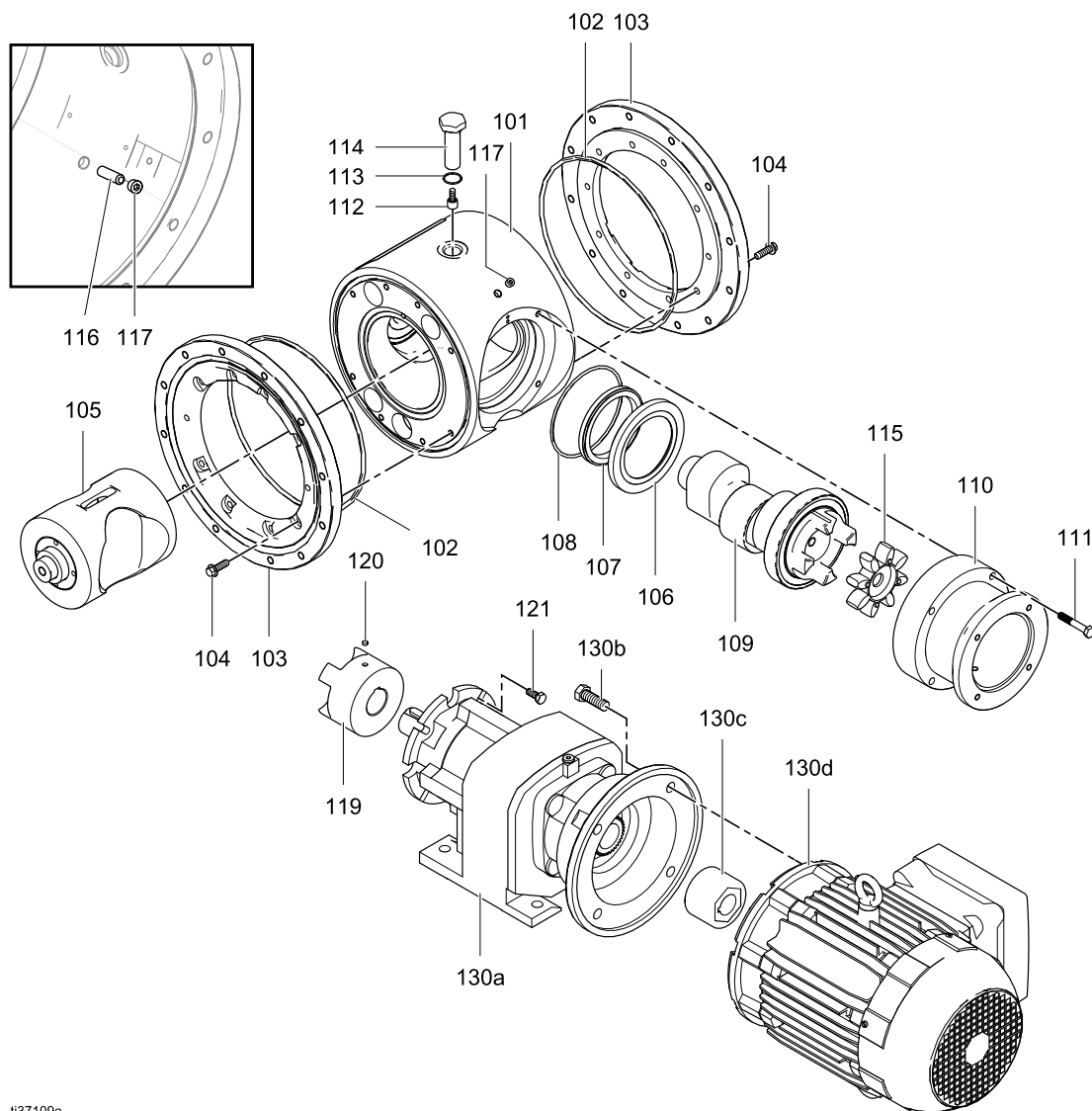

t137109a

Parts

Ref	Kit Ref	Description	Qty
101	209	HOUSING, center, assembly; <i>includes plugs</i>	1
102		O-RING, 374, Buna-N	2
103		RING, chamber	2
104		SCREW, hex washer head	16
105	— — —	PISTON, assembly	1
106		CARTRIDGE, seal	1
107	204 205	SEAL, radial	1
107a	204 205	O-RING, seal	1
108	204 205	O-RING	1
109	204	SHAFT, drive	1
110	210	HOUSING, alignment	1
111	— — —	SCREW	4
112	— — —	BEARING, cam follower	1
113	— — —	O-RING, Size 019, Fluoroelastomer	1
114	— — —	BOLT, bearing	1
115	203	COUPLER, shaft	1
116		PIN, pump	1
117	209	PLUG, pipe, headless	2
119	— — —	COUPLER, gearbox	1
120	— — —	MAGNET	1
121	214	SCREW, cap, hex head, M8 x 20 mm	4
130a	214	GEARBOX	1
130c	— — —	COUPLER	
130d	212	MOTOR	1
116	— — —	SCREW, socket head, M10 x 30 mm	1
117	210	SCREW, socket head, M6 x 40 mm	4

— — — *Not sold separately.*

Kit Table

Ref.	Kit	Description	Qty.
203	25R035	Kit, coupler, includes: Ref 115	1
204	25R036	Kit, shaft assembly, includes: Ref 107, 107a, 108, 109	1 ea
205	25R066	Kit, radial seal, includes: 106, 107, 107a, 108	1 ea
206	25r037	Kit, piston, includes Ref 105	1
207	25r038	Kit, diaphragm, 2-piece PTFE, includes: Ref 3, 4	1 ea
209	25r039	Kit, center section, includes: Ref 101	1
210	25r040	Kit, alignment housing, includes: Ref 110 Ref 111	1 4 ea
212	25r041	Kit, motor, 5 HP, flameproof, includes: Ref 130d	1
214	25r042	Kit, gear reducer, includes: Ref 130a Ref 130b	1 ea 4 ea
215	25R043	Kit, manifold assembly, includes: Ref 14 Ref 15, 17	2 ea 1 ea
216	25R044	Kit, check valves, includes Ref 10, 11	4 ea
217	25R045	Kit, diaphragm cover, includes: Ref 8 Ref 9 Ref 12, 13	1 ea 12 ea 2 ea
218	25D049	Kit, CO ₂ regulator, includes: Ref 38, 56	1 ea
219	25D050	Kit, stand legs, includes: Ref 25 Ref 24 Ref 52 Ref 29 Ref 30, 31 Ref 34	1 ea 2 ea 4 ea 9 ea 13 ea 6 ea
220	25R046	Kit, stand bracket, includes: Ref 23 Ref 29-31	1 ea 4 ea
221	25D052	Kit, fill/vent fittings, includes: Ref 17, 35, 36 Ref 37, 38	1 ea 2 ea
222	25R047	Kit, fitting, includes Ref 16	2
223	25R067	Kit, CO ₂ holder, includes: Ref 26, 27	1 ea

Technical Data

	US	Metric
Model MVP-150 Vapor Recovery Pump		
LP-Gas vapor recovery rate	18 cfm	5 m ³ /min
Butane recovery rate	3-4.5 lb/min	1.3-2 kg/min
Butane recovery and re-condense rate	35-50 GPH	135-200 L/hour
Propane recovery rate	4-6 lb/min	1.8-2.5 kg/min
Propane recovery and re-condense rate	50-70 GPH	180-270 L/hour
Maximum pumping outlet pressure	150 psi	1.03 MPa, 10.3 bar
Maximum pumping inlet vacuum produced	27 inHg	91 kPa, 0.91 bar
Maximum center section CO ₂ charge	150 psi	1.03 MPa, 10.3 bar
Equipment Withstand Pressure	375 psi	2.59 MPa, 25.9 bar
Maximum CO ₂ consumption	<0.2 scfh	<0.006 cubic meters/hour
CO ₂ inlet size	1/4 in. npt(f)	
Maximum pump speed	174 cpm	
Process Inlet and Outlet Size	1 in. JIC male	
Optional pressure gauge ports: inlet and outlet	1/4 in. npt(f)	
Weight	360.5 lb	163 kg
Electric Motor: Explosionproof for hazardous areas (see approvals page)		
Model MVP-150-3PH, inverter rated		
Power	5 Hp	3.7 kW
Speed	1800 rpm (30 Hz)	
Gear Ratio	100.4:1	
Voltage	3-phase 208-230/460V	
Maximum Amperage Load	13.1 A (716V) / 6.6 A (565V)	
Noise Data		
Sound Power (measured per ISO-9614-2)	88.5 dBa	
Sound Pressure [tested 3.28 ft (1 m) from equipment]	80.5 dBa	
Materials		
Process Pressure Section and Reed Valves	stainless steel	
Diaphragms	PTFE	
Process Vapor Temperature Range	-40°F to 220°F (-40°C to 104°C)	

MVP Standard Warranty

MVP warrants all equipment referenced in this document which is manufactured by MVP and bearing its name to be free from defects in material and workmanship on the date of sale to the original purchaser for use. With the exception of any special, extended, or limited warranty published by MVP, MVP will, for a period of twelve months from the date of sale, repair or replace any part of the equipment determined by MVP to be defective. This warranty applies only when the equipment is installed, operated and maintained in accordance with MVP's written recommendations.

This warranty does not cover, and MVP shall not be liable for general wear and tear, or any malfunction, damage or wear caused by faulty installation, misapplication, abrasion, corrosion, inadequate or improper maintenance, negligence, accident, tampering, or substitution of non-MVP component parts. Nor shall MVP be liable for malfunction, damage or wear caused by the incompatibility of MVP equipment with structures, accessories, equipment or materials not supplied by MVP, or the improper design, manufacture, installation, operation or maintenance of structures, accessories, equipment or materials not supplied by MVP.

This warranty is conditioned upon the prepaid return of the equipment claimed to be defective to an authorized MVP distributor for verification of the claimed defect. If the claimed defect is verified, MVP will repair or replace free of charge any defective parts. The equipment will be returned to the original purchaser transportation prepaid. If inspection of the equipment does not disclose any defect in material or workmanship, repairs will be made at a reasonable charge, which charges may include the costs of parts, labor, and transportation.

THIS WARRANTY IS EXCLUSIVE, AND IS IN LIEU OF ANY OTHER WARRANTIES, EXPRESS OR IMPLIED, INCLUDING BUT NOT LIMITED TO WARRANTY OF MERCHANTABILITY OR WARRANTY OF FITNESS FOR A PARTICULAR PURPOSE.

MVP's sole obligation and buyer's sole remedy for any breach of warranty shall be as set forth above. The buyer agrees that no other remedy (including, but not limited to, incidental or consequential damages for lost profits, lost sales, injury to person or property, or any other incidental or consequential loss) shall be available. Any action for breach of warranty must be brought within two (2) years of the date of sale.

MVP MAKES NO WARRANTY, AND DISCLAIMS ALL IMPLIED WARRANTIES OF MERCHANTABILITY AND FITNESS FOR A PARTICULAR PURPOSE, IN CONNECTION WITH ACCESSORIES, EQUIPMENT, MATERIALS OR COMPONENTS SOLD BUT NOT MANUFACTURED BY MVP. These items sold, but not manufactured by MVP (such as electric motors, switches, hose, etc.), are subject to the warranty, if any, of their manufacturer. MVP will provide purchaser with reasonable assistance in making any claim for breach of these warranties.

In no event will MVP be liable for indirect, incidental, special or consequential damages resulting from MVP supplying equipment hereunder, or the furnishing, performance, or use of any products or other goods sold hereto, whether due to a breach of contract, breach of warranty, the negligence of MVP, or otherwise.

FOR MVP CANADA CUSTOMERS

The Parties acknowledge that they have required that the present document, as well as all documents, notices and legal proceedings entered into, given or instituted pursuant hereto or relating directly or indirectly hereto, be drawn up in English. Les parties reconnaissent avoir convenu que la rédaction du présente document sera en Anglais, ainsi que tous documents, avis et procédures judiciaires exécutés, donnés ou intentés, à la suite de ou en rapport, directement ou indirectement, avec les procédures concernées.

MVP Information

For the latest information about MVP products, visit MasterVaporPumps.com.

Protected as patented technology.

To place an order, contact your MVP Distributor or call to identify the nearest distributor.

Toll Free: 1-888-502-3303

Email: info@MasterVaporPumps.com

All written and visual data contained in this document reflects the latest product information available at the time of publication.

MVP reserves the right to make changes at any time without notice.

Original Instructions. This manual contains English. MM 3A7034

MVP Headquarters: Santa Cruz

**Master Vapor Pumps LLC • 849 Almar Ave., Suite C, #209 • Santa Cruz CA 95060• USA
Copyright 2018, Master Vapor Pumps LLC.**

MasterVaporPumps.com
Revision A, November 2019