



NLDC-25
DC-DC CHARGER
Dual Battery System & Solar Charger



25A

OWNERS MANUAL

Index

Introduction	1
Safety Information	1
External features	2
Preparing for Installation	3
Fitting the NLDC-25	3
Universal Mounting Fixture	4
Typical Installation diagram	6
Installation steps	7
Selecting battery type	7
Ignition over-ride	8
Temperature compensation	8
Remote monitor	9
Remote monitor operation	10
Remote monitor warning messages	11
Application examples	12
Specifications	15

NLDC-25 Dual Battery Isolator and Charger

The NLDC-25 from National Luna is a DC to DC battery charger and isolator for a dual-battery system. It will charge an auxiliary or service battery from a vehicle alternator or Solar panel up to 25A output current. Traditional 12V and 24V vehicle alternators as well as variable voltage alternators are supported.

The integrated MPPT solar regulator provides a maximum output power of 375W but can support solar panels higher than this. Solar panel voltages up to 42V can be connected.

The NLDC-25 features a 6-stage charge algorithm that is suitable for any Lead-Acid battery type as well as automotive Lithium-Ion batteries. 3 safety stages analyse the battery and can detect batteries that are damaged and unable to accept charge. Temperature compensation is used to optimise the output voltage, ensuring safe and full battery charging under various conditions.

The NLDC-25 supports the connection of a remote monitor that displays information about the system and battery levels to the user on a high-contrast LCD screen.

The NLDC-25 has a IP67 rating for harsh environments and is protected against reverse-polarity, over-voltage, over-temperature and over-current conditions.

SAFETY INFORMATION :

- Before installation, read the instructions carefully.
- Before installation, disconnect any existing batteries.
- The NLDC-25 is used for charging 12V lead-acid and automotive Lithium batteries only.
- Do not use for any purpose other than battery charging.
- Do not attempt to power any devices or instruments directly using the output of NLDC-25.
- Do not attempt to charge a non-rechargeable or battery other than 12V.
- Never attempt to charge a damaged battery or leaking battery.
- Avoid open flames in the vicinity of the battery.
- Battery acid is highly corrosive. If your skin or eyes come into contact with acid, immediately rinse the affected area with water and seek medical advice.
- Do not alter or disassemble the NLDC-25 under any circumstances.
- Unauthorized disassembly, repairs or modifications will void any warranty.
- Attempts to use the NLDC-25 for purposes other than indicated in this manual will void the warranty.
- Ensure all connections are secure and cables are installed in a safe manner.
- Use the correct cabling size and fuses in accordance with the installation instructions.

NLDC-25 Features

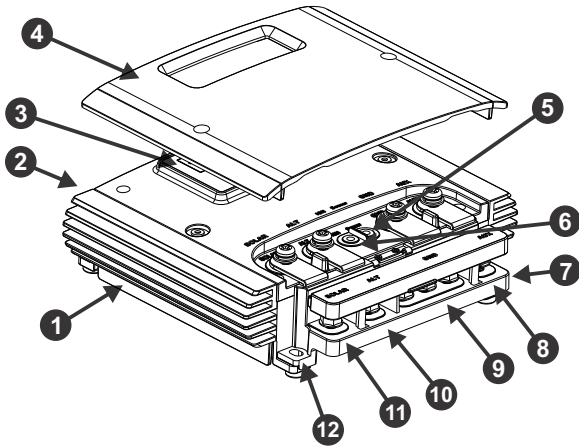

NLDC-25 External features

- 1 - NL-DC25 Metal Base
- 2 - Remote monitor connecting port
- 3 - Status display
- 4 - Removable top cover
- 5 - Temperature compensation input
- 6 - Ignition over-ride input
- 7 - Removable terminal block
- 8 - Terminal block - Auxiliary battery output
- 9 - Terminal block - Common ground connections
- 10 - Terminal block - Alternator input
- 11 - Terminal block - SOLAR panel input
- 12 - Mounting feet

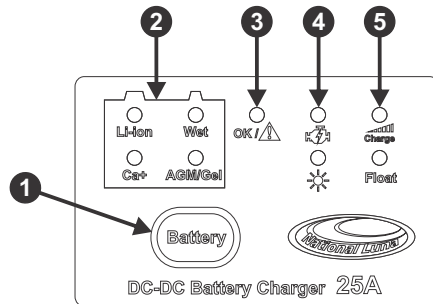

Status Display

- 1 - Battery type selection button
- 2 - Battery type indicator
- 3 - OK / Fault indicator : Green = OK, Red = Fault
- 4 - Input source indicator (ALT or SOLAR)
- 5 - Charge stage indicator

Preparing for Installation

- The NLDC-25 should be located close to the auxiliary battery for best voltage regulation.
- The NLDC-25 can operate in harsh environments but it is best installed in a location that is cooler with adequate ventilation.
- Avoid areas exposed to harsh or corrosive chemicals, excessive dust, extreme heat or mechanical movement.
- The NLDC-25 can be installed vertically or horizontally.
- Do not block or obstruct the cooling fins on the NLDC-25.
- Allow clearance around the NLDC-25 for cables and ventilation.
- It is normal for the NLDC-25 to get hot during operation, keep any objects that are heat-sensitive away from the NLDC-25.
- If the temperature compensation probe is used, it must be able to reach the auxiliary battery.
- It is recommended to use 16mm² cables for connections to the main and auxiliary batteries. Smaller gauge cables can be used for short distances.
- In-line fuses must be fitted in the positive cables close to the respective main and auxiliary batteries.
- Use the common ground connections on the terminal block for all negative cable connections.
- Use appropriate cable lugs for the cable size used.

Removing the top cover

In order to select the battery type and to install the temperature compensation & ignition over-ride wires, the top cover will need to be removed.

Loosen the two screws as indicated in order to release the cover.

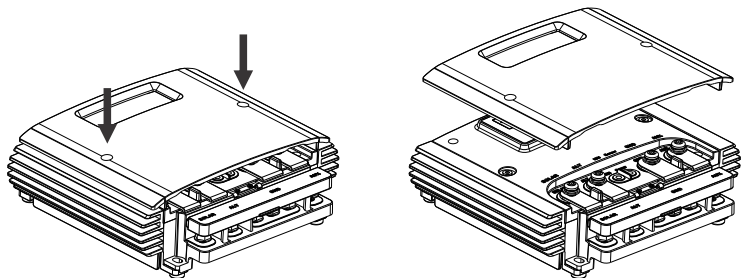

Fitting the NLDC-25

The NLDC-25 has 4 mounting feet, use these to attach the NLDC-25 to a secure, flat surface.

Use appropriate screws or bolts to attach the NLDC-25 securely, M4 machine bolts are recommended.

DO NOT drill into or modify the NLDC-25 housing.

Allow enough clearance for power cables to connect to the terminal block. 50mm or more is recommended.

It is recommended to secure cables together and prevent excessive movement in the final application.

If the remote monitor is fitted, allow clearance for the plug and cable.

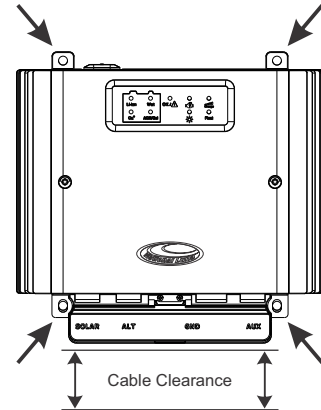

Universal mounting fixture

The NLDC-25 is supplied with a universal mounting fixture and fasteners that can be used to aid installation in a variety of applications.

This fixture allows the NLDC-25 to be attached in several ways depending on the application requirements.

Use the supplied screws and washers to secure the NLDC-25 to the plate in the chosen orientation.

Secure the fixture in the final application with appropriate fasteners.

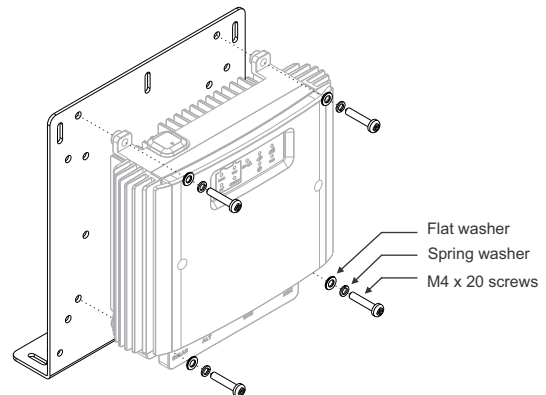

Step plates

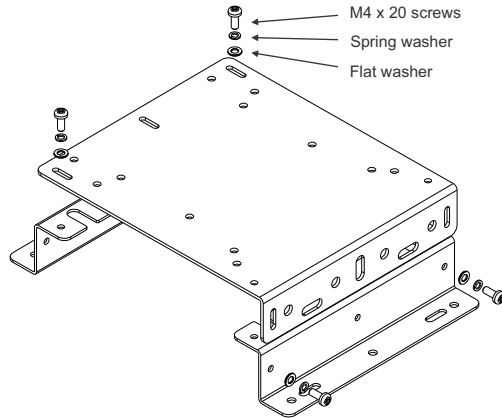

The supplied step-plates can be used to raise the NLDC-25 above obstructions such as pipes or cables if necessary.

Use the supplied screws and washers to assemble the fixture as shown in the diagram.

Use appropriate fasteners to secure the assembled plate to the application.

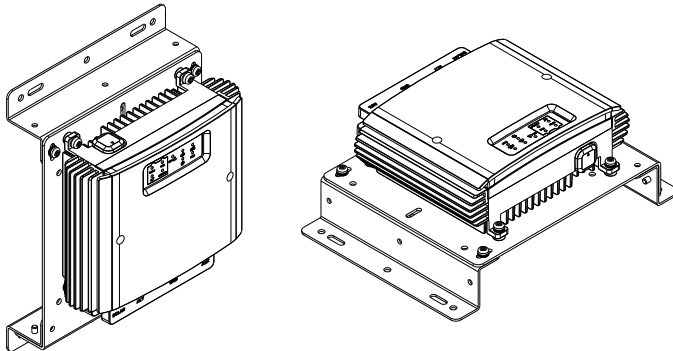

The NLDC-25 can be rotated on the plate by 90° to suite the application.

Vertical or horizontal installation is supported.

Typical Installation

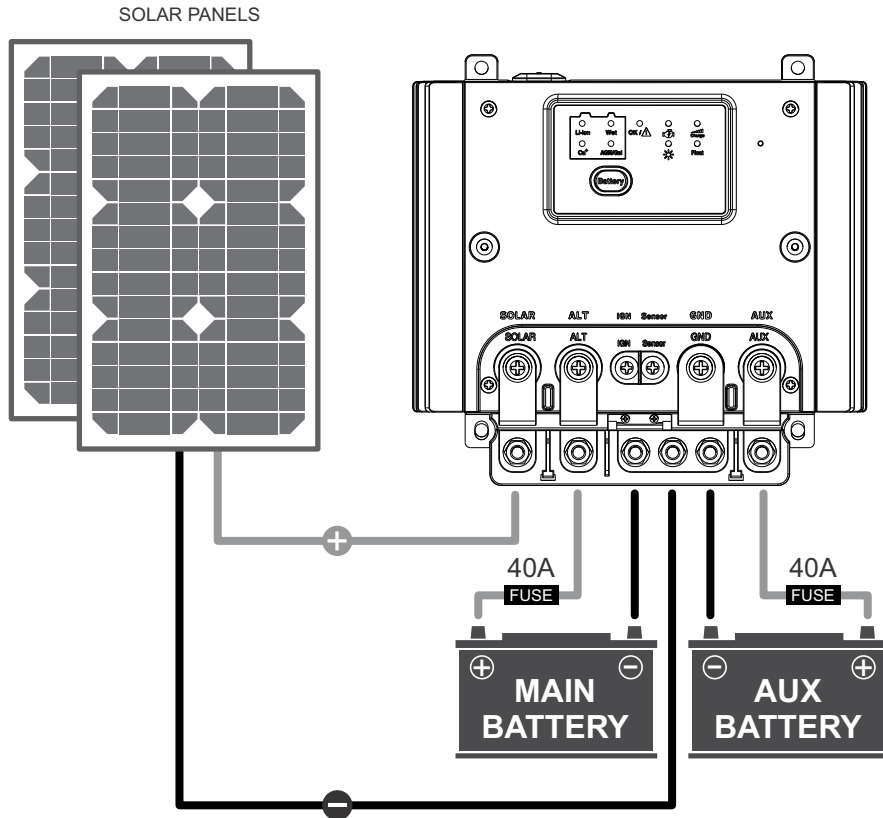

Installation Steps

- Disconnect the main battery before starting installation.
- Install the NLDC-25 using the mounting feet. (*Described on page 4*).
- Install positive and negative cables from the Auxiliary battery to the NLDC-25. Connect to the AUX and GND terminals respectively.
- Install one in-line fuse on the positive cable near to the Auxiliary battery. Do not connect the battery yet.
- Install positive and negative cables from the NLDC-25 to the Main battery. Connect to the ALT and GND terminals respectively.
- Install one in-line fuse on the positive cable near to the Main battery.
- If a solar panel is used, connect the positive and negative cables from the solar panel to the SOLAR and GND terminals respectively.
- Connect the temperature compensation probe and IGN over-ride cable if used. (*See page 8*).
- Install the remote monitor (if used) and run its cable to the remote monitor port on the NLDC-25. (*See page 9*).
- Double check all cables and connections for correct installation.
- Re-connect the Main battery. The NLDC-25 should now be powered and will show status on the status display.
- Select the Auxiliary battery type. See “Selecting Battery Type” below.
- Connect the Auxiliary battery.
- If the remote monitor is installed, the voltages of the Main and Auxiliary batteries will now be displayed.
- The system is now ready.

Selecting Battery Type

The NLDC-25 will optimise charge voltage based on the selected battery type.

For safety reasons, the battery type cannot be changed if the AUX battery is already connected.

Remove the NLDC-25 top cover to access the battery select button.

The battery type can be selected by pressing the “Battery” button on the NLDC-25 control panel. The chosen battery type is displayed.

Li-ion	Used for automotive Lithium-ion or LiFe batteries.
Wet	Used for regular automotive starting and flooded high-cycle batteries.
Ca+	Used for flooded deep-cycle, calcium and maintenance-free batteries.
AGM / Gel	Used for all types of AGM and Gel batteries.

IGN over-ride

The ignition (IGN) over-ride input can be used in vehicles that have variable alternator output. This is common with “Smart” alternators.

Connect the IGN terminal using a small gauge wire to a 12V ignition lead or source in the vehicle. This source must be switched to a positive voltage when the vehicle is started and switched off when the vehicle is turned off.

If the IGN feature is used, the Turn-ON and Turn-OFF voltages of the NLDC-25 are adjusted (*See specifications on page 15*).

CAUTION - DO NOT connect the IGN over-ride permanently to a non-switched positive source. Doing so may result in excessive drain on the Main battery.

Temperature sensor

The NLDC-25 is supplied with a temperature compensation probe. For best performance, connect the probe end to one of the AUX battery terminals or to the battery casing.

Connect the smaller ring on the sensor cable to the “sensor” terminal on the NLDC-25. Connect the larger ring to one of the GND terminals.

With the probe fitted, the NLDC-25 will optimise final charge voltage based on the measured temperature. This prevents over-charge at higher temperatures and increases charge performance at lower temperatures.

For safety, charge is stopped if the battery temperature increases above 60°C.

Fitting the temperature probe in a location other than on the AUX battery can increase the risk of battery over or under-charging.

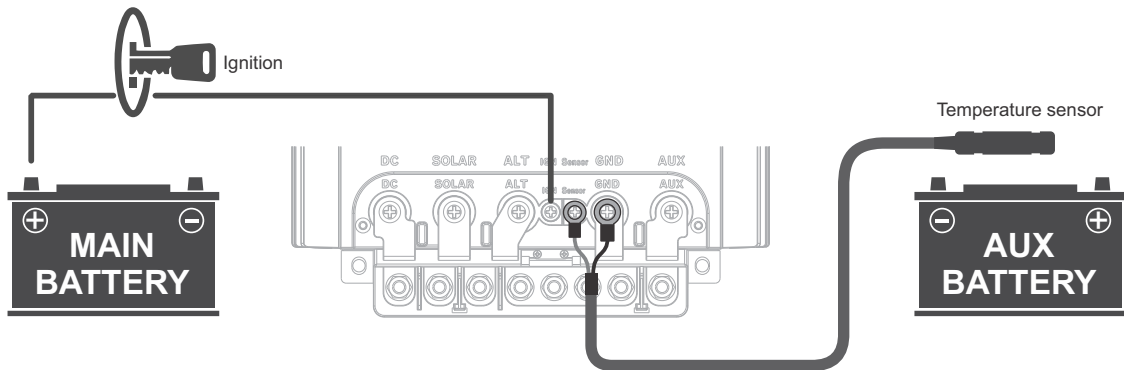

Remote monitor - (Optional accessory)

The Remote Monitor for the NLDC-25 provides status information about the system and batteries on a high-contrast LCD screen.

Information such as Main and Auxiliary battery voltages, charge mode, charge current, battery type, battery temperature and error conditions are displayed on a choice of 3 user-selectable display modes.

In addition to the selectable screen modes, the user is able to increase or decrease the screen brightness and choose to turn the display on or off.

The screen will turn off automatically when the system is idle. It will turn on automatically when the next charge cycle starts.

Connecting the Remote monitor

The Remote Monitor is supplied with a mounting bracket that allows the viewing angle to be adjusted.

Attach the bracket to a flat surface using appropriate screws or adhesive. Slide the Remote Monitor onto the mounting bracket until it clicks securely.

Connect the square end of the supplied data cable to the NLDC-25 remote port, it can fit in one direction only (*fig 1*). Press the plug until it clicks securely and forms a waterproof seal.

Connect the flat end of the data cable to the Remote Monitor. (*fig 2*). This connector can fit both ways.

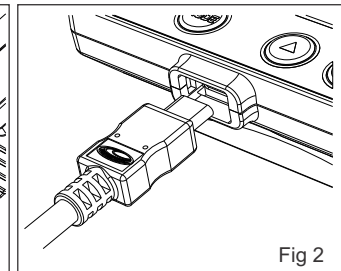
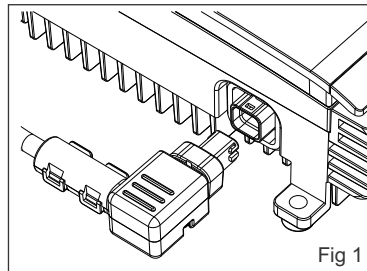
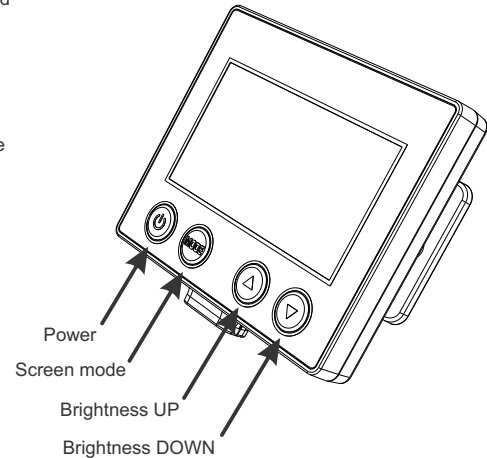

Remote display operation

The remote monitor can be turned ON or OFF by pressing the **POWER** button.
The display will turn off automatically after a short delay if there is no active charge cycle.
The display brightness can be increased or decreased by pressing the **UP** or **DOWN** buttons.

The remote monitor has 3 display modes that represent the status of the charging system in different ways.
Press the **MODE** button to cycle through the different display options.

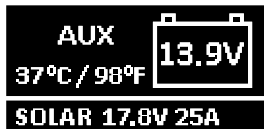

Display mode 1 - This mode focuses on the auxiliary battery with the majority of the screen used to show the auxiliary battery voltage and temperature (if probe is installed).

The input source (ALT or SOLAR) as well as charge current is displayed during a charge cycle.
If SOLAR is the active charge source, the solar panel voltage is displayed.
If there are no active charge cycles, "STBY" is displayed.

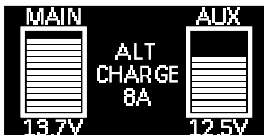

Display mode 2 - In this mode, the status of the main and auxiliary batteries are represented as graphical bar-graphs. The actual voltages are shown for the respective batteries.

During a charge cycle, the input source (ALT or SOLAR) is displayed with the actual charge current.
If there is no active charge cycle, "STANDBY" is displayed.
The AUX graph is animated during charge and represents the battery state of charge.



Display mode 3 - This mode shows voltages of the respective main and auxiliary batteries as well as charger mode, charge current, battery type and battery temperature (if probe is installed).

If there are no active charge cycles, "STBY" is displayed.

Charge Status

The remote monitor will show the charge status during an active charge cycle.

During the normal bulk and absorption charge stage, the charge current will be shown as well as the input source. During the Analysis stage, "TEST" will be shown. This stage helps to detect a defective battery. During the Float stage, "FLOAT" is shown.

Warning Messages

The remote monitor will respond and indicate various error conditions that may occur under normal operation. These warnings should be investigated to prevent damage to the batteries or the NLDC-25 system.

The following symbols or messages may appear on any of the 3 display modes :



LOW BATTERY or NO BATTERY - This symbol is displayed when either the Main or Auxiliary battery voltage is lower than 11.4V or there is no connection to one of the batteries. Check fuses and connections to both batteries.
If this symbol and voltage display are flashing, the battery is not holding charge and should be tested.

OVP - OVER VOLTAGE PROTECTION - The voltage applied to the SOLAR, ALT or AUX terminals is too high. Ensure the applied voltages are within specification. *Refer to specifications on page 15.*

OTP - OVER TEMPERATURE PROTECTION - The detected auxiliary battery temperature is above 60°C. Charging is stopped to prevent damage to the battery. It is possible that the battery is damaged or is located in an area that is too hot. This error will also be displayed if the NLDC-25 temperature is above 115°C. Charge will stop until the system temperature drops to a safe level.

OCP - OVER CURRENT PROTECTION - The detected charge current is higher than specification. Inspect the installation for cable faults or short-circuits.

REV - REVERSE POLARITY - The connections to the auxiliary battery have been reversed. Check the battery connections.

BAD - BAD BATTERY - The NLDC-25 has detected that the AUX battery is not able to be charged safely. Test the battery and replace if necessary.

Please check cable The plug to the remote monitor may not be inserted correctly. Ensure it is fully inserted.

Application examples

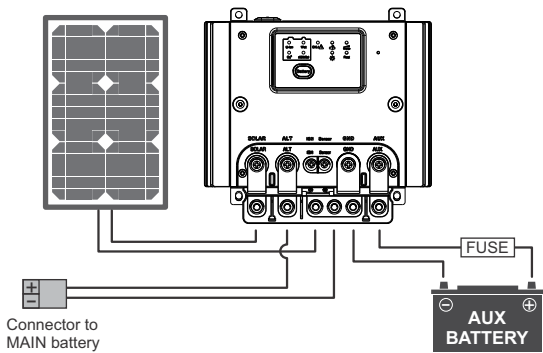

Installation in a Trailer or Caravan

The NLDC-25 can be installed in a Trailer or Caravan that is equipped with batteries. In this application, the NLDC-25 supports a stand-alone application with solar input as well as a removable connection to the towing vehicle's main battery.

More than one solar panel can be connected.
(See specifications on page 15).

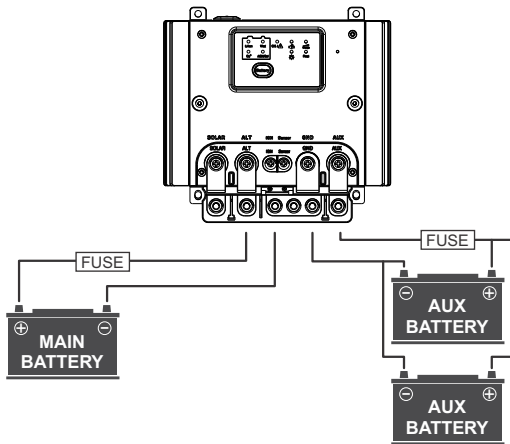

Multiple Auxiliary batteries

The NLDC-25 will support multiple auxiliary batteries connected in parallel to form a large 12V bank. This is a common configuration in trailers or caravans with large service battery banks.

Care should be taken to ensure that the parallel batteries are matched in type, capacity and age.

Application examples

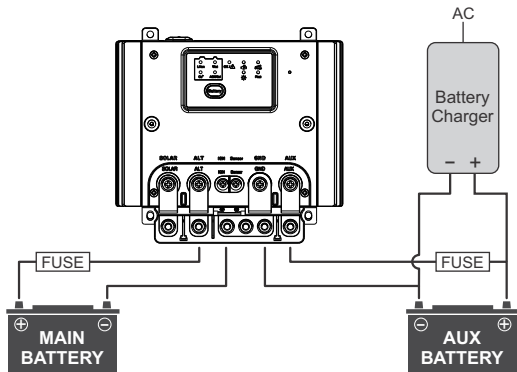

Connecting an external battery charger.

In cases where the auxiliary battery has had insufficient charging time, a mains-powered battery charger can be connected to the auxiliary battery.

It is not necessary to disconnect the NLDC-25, provided that there is no active charge cycle and the NLDC-25 is in standby mode.

Do not connect an external battery charger if power is being delivered from a solar panel or the vehicle alternator is running.

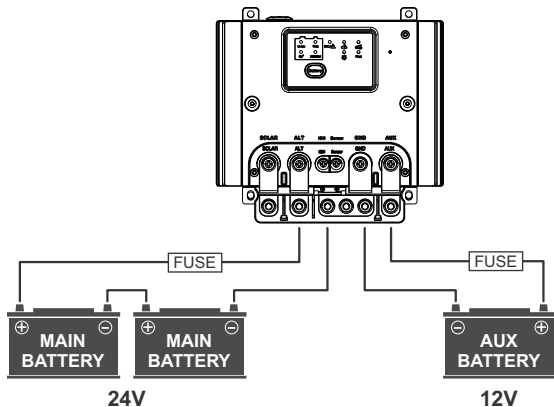

24V vehicles.

The NLDC-25 directly supports vehicles with 24V alternators. Usually these vehicles have two 12V main batteries connected in series.

The output of the NLDC-25 will charge a 12V battery or battery bank.

This is useful when 12V accessories are used in a vehicle with a 24V electrical system.

Application examples

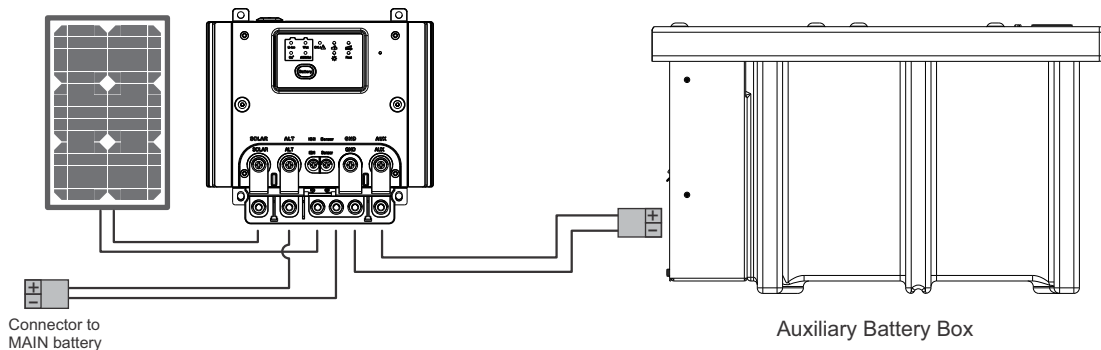

Connecting an external battery pack

The NLDC-25 can be directly connected to the input of a National Luna Auxiliary Battery Box or other 12V battery pack. Any loads connected to the battery will be powered by the NLDC-25 when a charge cycle is active.

If the Auxiliary Battery Box is disconnected, the NLDC-25 will automatically revert to a safe mode. An error will appear on the remote monitor, if installed (see page 11).

Technical Specifications

Voltage Range		
Alternator	11V - 32V	
Solar	9V - 42V	
Solar Regulator		
Type	MPPT	
Output Current	25A	
Output Power	375W	
12V Alternator Input		
Turn ON	13.2V	
Turn OFF	12.6V	
Over-Voltage	14.8V - 16V	
24V Alternator Input		
Turn ON	26.4V	
Turn OFF	23.2V	
Over-Voltage	29.6V - 31V	
Ignition Over-ride (12V / 24V)		
Turn ON	12.0V	24.0V
Turn OFF	11.5V	23V
Over-Voltage	15.5V - 16V	31V - 32V
Output		
Voltage	3V -14.8V	
Current	25A	
Power	375W	
Operating Temperature	-20°C to 85°C	
Standby Current	< 10mA	
Ingress Protection	IP67	
Standards	EN55011, AS/NZS CISPR11	
Dimensions	158mm x 115mm x 53mm	
Remote Display	Optional	
Battery Types	Bulk Voltage	Float Voltage
AGM / Gel	14.4V	13.6V
Standard Wet	14.6V	13.6V
Calcium	14.8V	13.6V
Lithium Ion	14.4V	13.6V

Battery Temperature Compensation	
High temperature	-17mV per °C above 30°C
Low Temperature	+17mV per °C below 21°C
Battery over-temperature protection	60°C
Device Protection	
Reverse Polarity	
Over Voltage	
Over Current	
Over Temperature	
Bad Battery Detect	

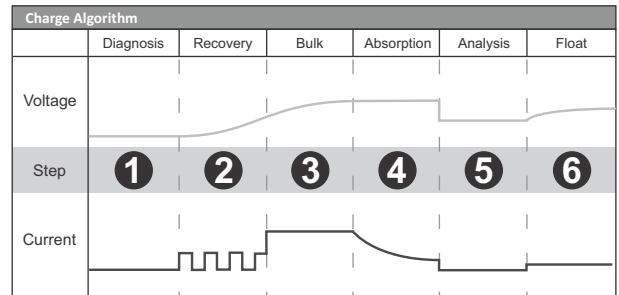

Technical Specifications - continued

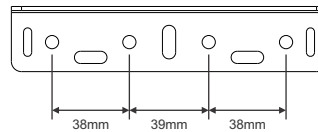
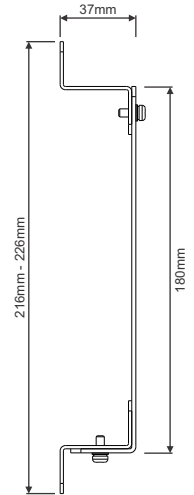
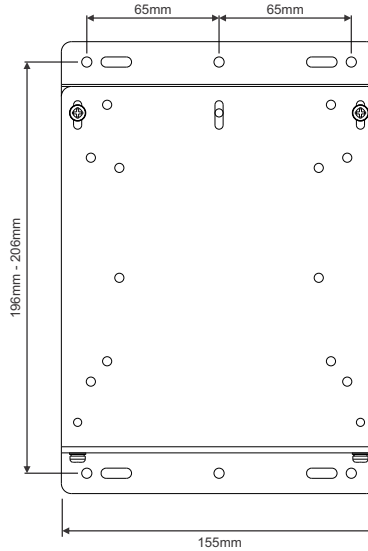
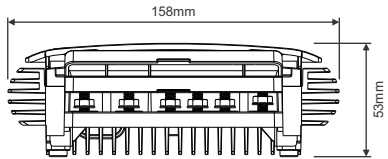
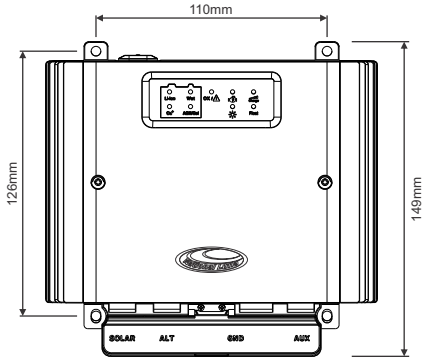

National Luna Limited Warranty - South Africa Only

This National Luna Warranty supersedes any other advertised Guarantee or Warranty provided with this appliance by any wholesaler or retailer.

National Luna warrants this product to be free from defects in materials and / or workmanship under normal use and service to the original purchaser subject to the following :

1. At any time within FIVE YEARS from the date of purchase by the original purchaser, National Luna will at its discretion replace or repair without cost to the owner, through an authorised service agent, any part found to be defective by National Luna.
2. Where parts are replaced by an authorised service agent, the labour account for the work done will be for the owner's account.
3. This warranty does not apply to accessories or items where the length of life depends on the amount of use and care given.
4. This warranty is valid in South Africa only.
5. National Luna may consider a warranty void if modifications have been made to this product which may cause undesirable or hazardous operation or may be the cause of the malfunction of this product.
6. National Luna shall not be responsible for any damages of any kind resulting from incorrect voltages or faults with regards to power supply which fall outside of the appliance operating specifications.
7. National Luna shall not be responsible for damage to the product caused by negligent use, storage of hazardous chemicals, use of corrosive substances, fire, flood, civil-disturbances, lightning or any other natural phenomenon.
8. Warranty returns to the factory for repairs - in the event where the unit has been shipped to the factory for repairs, transport costs will be for the owners account.
9. National Luna will not accept any responsibility for the consequential loss or damage caused by, or due to the malfunctioning of this appliance.
10. National Luna shall not be held responsible for any injuries to persons caused by the incorrect or negligent usage of this appliance.
11. Repair work to be done in terms of this warranty must be referred to National Luna for written authorisation before any work is carried out.
12. National Luna reserves the right to refuse repair or service under warranty if the original proof of purchase cannot be produced.
13. Proof of purchase and purchase date must be presented with submission of a warranty claim. All units have a unique serial number. (Removal of the serial number on the appliance will render this warranty void).

National Luna sales and support :
www.nationalluna.com