



8 Step Fully Automatic

Intelligent

BATTERY CHARGER

»» 12V 5A ««

USER'S MANUAL

Charges & Maintains

Flooded (WET), MF, VRLA, AGM, GEL & Calcium batteries



User's Manual And Guide To Professional Battery Charging

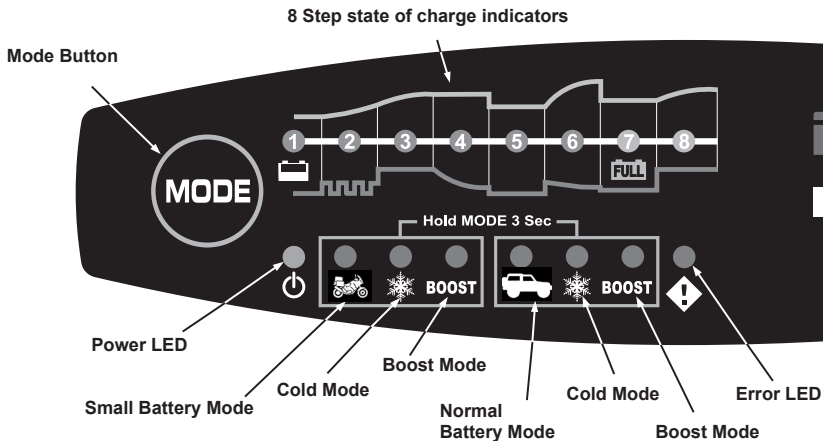

For Your Safety

This manual contains important safety and operating instructions. Read this manual carefully before using the charger for the first time and keep the manual in a safe place for future reference.

Kit Includes / Contents of Package

- 1) **NL 5Amp 8 Step Intelligent Battery Charger**
- 2) Quick contact battery leads with clamps
- 3) Quick contact battery leads with eyelet terminals (Ø 6.5mm) with in-line battery protection fuse (10A) for permanent attachment to the battery posts to allow quick connection/disconnection using a snap-connector.

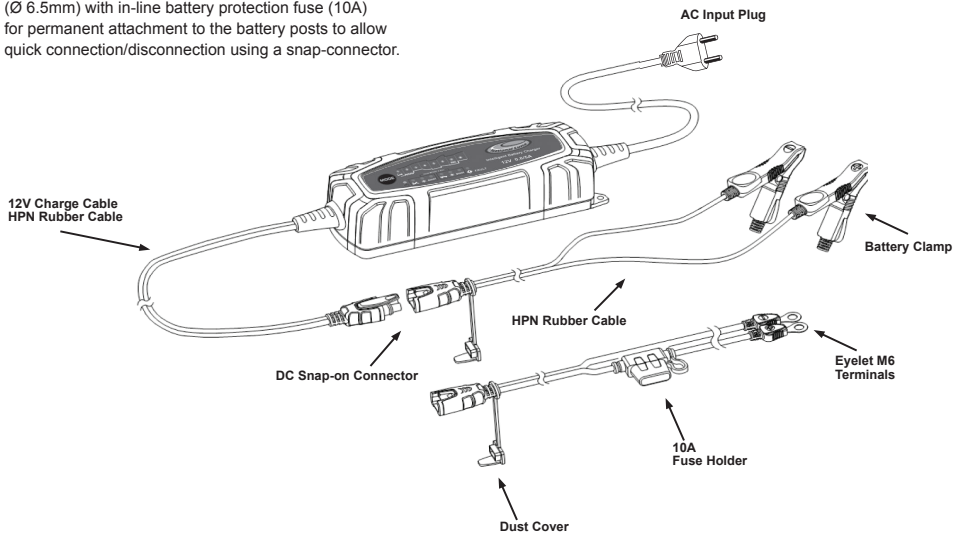

SAFETY INFORMATION





NL 5Amp 8 Step Intelligent Battery Charger is designed for charging 12V 1.2-160Ah Lead-Acid rechargeable batteries. Flooded (WET), MF,VRLA,AGM,GEL & Calcium.







WARNING! DO NOT ATTEMPT TO CHARGE A NON-RECHARGEABLE BATTERY (PRIMARY CELLS)

- Before charging make sure the AC input power is as per rated specifications.
- **Do not** use the charger with a damaged cable. It must be replaced by the manufacturer, its service agent or similarly qualified technician in order to ensure safety.
- Never charge a damaged battery.
- Never charge a frozen battery.
- Never place charger above the battery being charged. (Gasses from the battery will corrode and damage the charger).
- Do not cover the charger while charging.
- During charging the battery must be placed in a well ventilated area.
- While charging always use safety glasses, gloves, protective clothing and keep your face away from the battery.
- **Explosion hazard!** A battery being charged could emit explosive gasses. Avoid smoking or open sparks or flames in the vicinity of the battery. Explosive and flammable substances such as fuel or solvents should not be kept in the vicinity of the charger or the battery.
- **Danger of chemical burns!** Battery acid is highly corrosive. If your skin or eyes come into contact with acid, immediately rinse the affected part of the body with water and seek medical advice.
- Ensure that charger switches to maintenance charge mode, (i.e. Stage 7) before it is left unattended and connected for a long time.
- All batteries eventually fail. If that happens during charging, the charger's advance control system will detect it. There be may be some rare errors that still exist in the battery, so do not leave charging unattended for a long period of time.
- Normally, a battery is grounded either on negative or positive terminal to the vehicle's chassis. The charger's DC battery clamps are to be connected to the battery terminal **not connected to the chassis first**. The other connection is to be made to the battery terminal **connected to the chassis**, far from the battery and fuel line. The battery charger is then to be connected to the AC power supply.
- After charging, first disconnect the battery charger from the AC mains supply. **Then remove the chassis connection and the battery connection**, respectively. This will reduce back drain current.
- **Children should not play with this appliance.** Cleaning and user maintenance should not be made by minors without supervision.

CHARGING MODES

	<p>Mode 14.4V/0.8A This mode is suitable for batteries less than 12Ah.</p>
	<p>Mode 14.7V/0.8A This mode is recommended for AGM batteries less than 12Ah. This mode is also suitable for charging batteries in sub-zero temperatures.</p>
	<p>Mode 14.4V/0.8A + 16.0V/0.3A This mode is suitable to recover severely discharged batteries smaller than 12Ah. <i>(Recommended to boost at least once a year).</i></p>
	<p>Mode 14.7V/0.8A + 16.0V/0.3A This mode is suitable to recover severely discharged AGM batteries smaller than 12Ah or charging in sub-zero temperatures.</p>

	<p>Mode 14.4V/5.0A This mode is used for Flooded (WET), MF, VRLA, AGM, GEL and Calcium batteries.</p>
	<p>Mode 14.7V/5.0A This mode is recommended for AGM batteries. This mode is also suitable for charging batteries in sub-zero temperatures.</p>
	<p>Mode 14.4V/5.0A + 16.0V/1.5A This mode is suitable to recover severely discharged batteries. <i>(Recommended to boost at least once a year).</i></p>
	<p>Mode 14.7V/5.0A + 16.0V/1.5A This mode is suitable to recover severely discharged AGM batteries or charging in sub-zero temperatures.</p>

CHARGING SET-UP

Charging using battery clamps

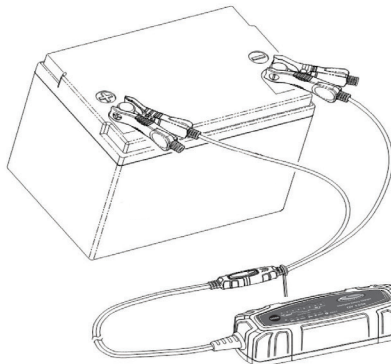

Charging using M6 eyelets

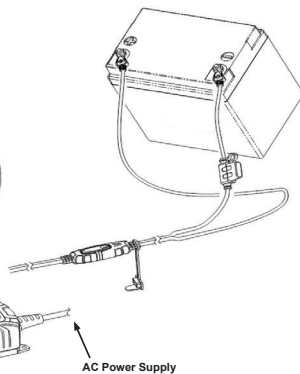

OPERATION

1) Charging of a permanently installed battery in a vehicle.

- Before connecting or disconnecting the battery leads, the AC power cord should be removed from the mains.
- Check polarity of the battery terminals. A positive battery terminal (+) usually has a larger diameter than a negative (-) battery terminal.
- Identify the terminal of the battery which is connected to the chassis (earth). Normally the negative terminal is connected to the chassis.
- In some cases the battery is installed in a vehicle in such a manner as to be inaccessible. The user would then have to use the vehicle chassis as a connection point. The positive charge point is normally clearly identified with a red protection cap.

Charging of a negatively earthed battery:

- Connect the red clamp or eyelet terminal (+) to the identified positive (+) terminal of the battery and the black clamp or eyelet terminal (-) to the vehicle chassis.
- Make sure the black clamp or eyelet terminal connection has no contact with the fuel line.

Charging of a positively earthed battery:

- Connect the black clamp or eyelet terminal (-) to the negative (-) pole of the battery and the red clamp or eyelet terminal (+) to the vehicle chassis.
- Make sure the red clamp or terminal (+) pole connection has no contact with the fuel line or the battery.

2) Charging of a battery not connected to a vehicle.

- Before connecting or disconnecting the battery leads, the AC power cord should be removed from the mains.
- Connect the red clamp or M6 eyelet terminal to the positive (+) terminal of the battery and the black clamp or eyelet terminal to the negative (-) terminal.
- Connect charger to the mains.

Select charging mode.



For Small batteries less than 12Ah





Press MODE button for 3 seconds to select charge mode.





For batteries larger than 12Ah up to 160Ah.

By pressing the MODE button several times a combination of COLD charge ❄️ and BOOST charge options can be selected.

Technical Data

Type of Charger	8 Step, fully automatic, switch mode with maintenance charging		
Type of Batteries	12V Lead acid rechargeable batteries (WET, MF, VRLA, AGM, GEL & Calcium)		
Input Voltage AC	220V-240VAC, 50/60Hz		
Output Voltage	Nominal : 12V		
Input Current	0.65A RMS Max.		
Minimum Battery Voltage	2.0V		
Output Power	60W		
Charging Voltage	 14.4V ± 0.25V	 14.7V ± 0.25V	BOOST 16.0V
Efficiency	80%		
Charging Current	 0.8A	 5A Max.	
Ambient Temperature	-30°C to 50°C, reduced output power at higher temperatures		
Battery Capacity	1.2-120Ah (charging) up to 160 Ah for maintenance		
Housing Protection	IP65 (dust and splash proof) outdoor		
Ripple Voltage	< 2%		
Back Current Drain*	5mA		
Noise Level	< 50dB (Tested from a distance of 50cm)		
Dimensions (LxWxH)	187x63x48mm		
Weight	0.75kg		

Bulk Charging Times

Battery Size (Ah)	MODE	For ± 80% charge (hours)
6	 0.8A	7
8		9
12		14
20	 5.0A	4
60		12
80		16
120		24

* Back current drain is the amount of current drawn by the charger from the battery, when the charger is connected to the battery without the AC power cord connected.



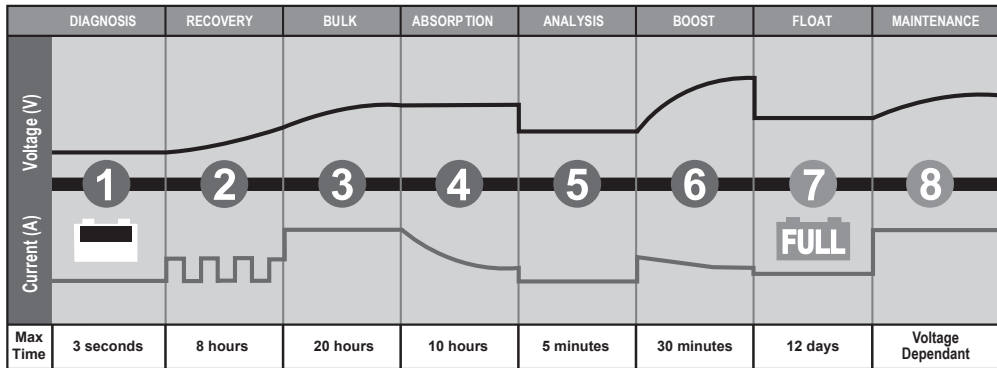

Batteries below 12Ah should not be charged with 5A current

THE NATIONAL LUNA NL 5Amp charger performs an 8-step fully automatic charging cycle.



- 1) Diagnosis :** This unique diagnostic function checks the status of a battery and ascertains if the battery can accept charging.
- 2) Recovery :** A deeply discharged battery of over 2.0V can be recovered and charged with pulse charging of a small current.
- 3) Bulk :** 80% of energy is returned in this phase with maximum charging current.
- 4) Absorption :** With use of declining current technology charging up to almost 100% is achieved.
- 5) Analysis :** Checks status of charge. If battery does not retain energy, it must be replaced.
- 6) Boost :** Recovers severely discharged batteries under high voltage charge.
(Recommended to apply it at least once a year.)
- 7) Float :** Battery is fully charged and ready to use.
The battery is maintained at maximum level by applying low current charge.
- 8) Maintenance Charge :** The charger continuously monitors the terminal voltage in order to determine if a maintenance charging should be initiated to keep battery fully charged. (i.e. When the charger is permanently connected).

Trouble Shooting

Problem	Indication	Possible Cause	Solution
Charger does not work	Indicator lights are not on	<ul style="list-style-type: none"> a) Charger is not plugged in b) Poor electrical connection c) AC outlet is dead 	<ul style="list-style-type: none"> a) Plug in b) Check AC connections and make sure mains is switched on c) Check receptacle
Charger has no DC output	 Flashing 	<ul style="list-style-type: none"> a) Battery is connected with reverse polarity poles b) Poor contact from charger to battery c) MODE button is not pressed d) Charging is interrupted in Phase 1 e) Charging is interrupted in Phase 2 f) Charging is interrupted in Phase 5 	<ul style="list-style-type: none"> a) Check DC connection between charger and battery and make sure they are not short circuited b) Check if connectors are not greasy or corroded and making a clean connection and there are no loose or damaged connection c) Select MODE d) Battery is extremely sulphated, it must be replaced e) Battery cannot accept charge, it must be replaced f) Battery cannot retain charge, it must be replaced
No charging current		<ul style="list-style-type: none"> a) Battery may be defective / excessive current draw b) Battery may be severely sulphated 	<ul style="list-style-type: none"> a) Dead battery, it should be replaced b) If battery cannot be de-sulphated, it must be replaced
No charging Phases	 Flashing	<ul style="list-style-type: none"> Charger is not connected to the battery for over 2 mins Charger is in energy save mode 	Switch off mains, connect battery and then switch on mains

FCC Statement:

This equipment has been tested and found to comply with the limits for a Class B digital device, pursuant to Part 15 of the FCC Rules. These limits are designed to provide reasonable protection against harmful interference in a residential installation. This equipment can radiate radio frequency energy and, if not installed and used in accordance with the instructions, may cause harmful interference to radio communications. However, there is no guarantee that interference will not occur in a particular installation. If this equipment does cause harmful interference to radio or television reception, which can be determined by turning the equipment off and on, the user is encouraged to try to correct the interference by one or more of the following measures:

- Reorient or relocate the receiving antenna.
- Increase the separation between the equipment and receiver.
- Connect the equipment into an outlet on a circuit different from that to which the receiver is connected.
- Consult the dealer or an experienced radio/TV technician for help.

This device complies with part 15 of the FCC Rules. Operation is subject to the following two conditions:

- (1) This device may not cause harmful interference, and
- (2) this device must accept any interference received, including interference that may cause undesired operation.

Changes or modifications not expressly approved by the party responsible for compliance could void the user's authority to operate the equipment.

Declaration of Compliance

Tested and approved by



and conforms to:

EN 60335-1	EN 61000-3-2
EN 60335-2-29	EN 61000-3-3
EN 55014-1	EN 62233
EN 55014-2	

CONTACT | +27 (0)11 452-5438 (tel) | +27 (0)11 452-5263 (fax) | info@nationalluna.com | www.nationalluna.com

STREET ADDRESS | 34 Plantation Road | Eastleigh, Edenvale | 1609 Johannesburg | South Africa

POSTAL ADDRESS | PO Box 8899 | Edenglen 1613 | Johannesburg | South Africa

Data Log Graph illustrating the recharge characteristics of the National Luna 5Amp Intelligent Charger applied to a 105 A/H deep cycle battery after it was subjected to a 70% depth of discharge. (i.e. 73.5 A/H was removed from the battery and then recharged over a 24hr period).

