

# POWERSMART<sup>®</sup>

## INSTRUCTION MANUAL

Pneumatic 21° Round Head Framing Nailer

Model # PS6120



Have product questions or need technical support? Please feel free to contact us!

Website: [www.Amerisuninc.com](http://www.Amerisuninc.com)

Toll free: 1-800-791-9458 M-F 9-5 EST

Email: [support@amerisuninc.com](mailto:support@amerisuninc.com)



# **CONTENTS**

Technical data.....	3
General safety rules.....	4
Knowing your framing nailer .....	8
Assembly .....	9
Operating instruction.....	9
Maintenance.....	12
Troubleshooting.....	13
Exploded view & parts list.....	14
Warranty.....	16

# **TECHNICAL DATA**

Pneumatic 21° Round Head Framing Nailer	Model # PS6120
Fastener angle:	21°
Fastener length :	2" – 3 1/2"
Fastener:	0.113"-0.130" diameter
Magazine capacity:	60
Air inlet (NPT):	1/4"
Operating pressure:	80-120 PSI
Package dimensions (L x W x H):	23.6 x 5.9 x 16.5 inches
Weight:	8.36 lb.

Thank you for purchasing PowerSmart products. Please register online at **www. Amerisuninc.com**.  
The information will allow us to track your warranty and update on your unit.

Important: Our company does not provide email or personal information to any third party for any reason. For any questions check our website or call customer service at (800)791 9458.

**Warning!** We strongly recommend that this item not be modified and/or used for any application other than that for which it was designed. If you have any questions relative to its application, do not use the equipment until you have consulted us and we have advised you.  
**Contact PowerSmart at (800)791-9458 M-F 9am-5pm EST**

## **GENERAL SAFETY RULES**

Safety is a combination of common sense, staying alert, and knowing how your framing nailer works. **SAVE THESE SAFETY INSTRUCTIONS.**



**WARNING:** Do not operate this unit until you read this instruction manual for safety, operation and maintenance instructions.



**WARNING:** This product contains chemicals known to the State of California to cause cancer, and birth defects or other reproductive harm. **Wash hands after handling.**



**WARNING:** Some dust contains chemicals known to the State of California to cause cancer, birth defects or other reproductive harm such as asbestos and lead in lead based paint.

**Actuating tool may result in flying debris, collation material, or dust which could harm operator's eyes.**

The operator and all those persons in the general area should wear safety glasses with permanently attached side shields. Approved safety glasses are imprinted with the characters "Z87.1". It is the employer's responsibility to enforce the use of eye protection equipment by the tool operator and other people in the work area.

**Always wear appropriate personal hearing and other protection during use.** Under some conditions and duration of use, noise from this product may contribute to hearing loss.

**Use only clean, dry, regulated air.** Condensation from an air compressor can rust and damage the internal workings of the tool.

**Regulate air pressure. Use air pressure compatible with ratings on the nameplate of the tool.** (Not to exceed 120 psi, 8.3 bar) Do not connect the tool to a compressor rated at over 200 psi. The tool operating pressure must never exceed 200 psi even in the event of regulator failure.

**Only use air hose that is rated for a maximum working pressure of at least 150 PSI (10.3 BAR) or 150% of the maximum system pressure, which ever is greater.**

**Do not use bottled gases to power this tool.** Bottled compressed gases such as oxygen, carbon dioxide, nitrogen, hydrogen, propane, acetylene or air are not for use with pneumatic tools. Never use combustible gases or any other reactive gas as a power source for this tool. Danger of explosion and/or serious personal injury may result.

**Use couplings that relieve all pressure from the tool when it is disconnected from the power supply.** Use hose connectors that shut off air supply from compressor when the tool is disconnected.

**Disconnect tool from air supply when not in use. Always disconnect tool from air supply and remove fasteners from magazine before leaving the area or passing the tool to another operator. Do not carry tool to another work area in which changing location involves the use of scaffoldings, stairs, ladders, and the like, with air supply connected. Do not make adjustments, remove magazine, perform maintenance or clear jammed fasteners while connected to the air supply.** If the

contact trip is adjusted when the tool is connected to the air supply and nails are loaded, accidental discharge may occur.

**Connect tool to air supply before loading fasteners, to prevent a fastener from being fired during connection.** The tool driving mechanism may cycle when tool is connected to the air supply. Do not load fasteners with trigger or contact trip depressed, to prevent unintentional firing of a fastener.

**Do not remove, tamper with, or otherwise cause the tool, trigger, or contact trip to become inoperable.** Do not tape or tie trigger or contact trip in the ON position. Do not remove spring from contact trip. Make daily inspections for free movement of trigger and contact trip. Uncontrolled discharge could result.

**Inspect tool before use. Do not operate a tool if any portion of the tool, trigger, or contact trip is inoperable, disconnected, altered, or not working properly.** A tool that is not in proper working order must not be used. Tags and physical segregation shall be used for control. Leaking air, damaged parts or missing parts should be repaired or replaced before use.

**Do not alter or modify the tool in any way.**

**Always assume that the tool contains fasteners.**

**Do not point the tool at co-workers or yourself at any time.** No horseplay! Work safe! Respect the tool as a working implement.

**Keep bystanders, children, and visitors away while operating a power tool.** Distractions can cause you to lose control. When tool is not in use, it should be locked in a safe place, out of the reach of children.

**Remove finger from trigger when not driving fasteners. Never carry tool with finger on trigger.** Accidental discharge could result.

**Do not lift, pull or lower tool by the hose.**

**Do not overreach.** Maintain proper footing and balance at all times. Loss of balance may cause personal injury.

**Make sure hose is free of obstructions or snags.** Entangled or snarled hoses can cause loss of balance or footing.

**Use the tool only for its intended use. Do not discharge fasteners into open air, concrete, stone, extremely hard woods, knots or any material too hard for the fastener to penetrate. Do not use the body of the tool or top cap as a hammer.** Discharged fasteners may follow unexpected path and cause injury.

**Always keep fingers clear of contact trip to prevent injury from inadvertent release of nails.**

**Refer to the Maintenance and Repairs sections for detailed information on the proper maintenance of the tool.**

**Always operate the tool in a clean, lighted area.** Be sure the work surface is clear of any debris and be careful not to lose footing when working in elevated environments such as rooftops.

**Do not drive fasteners near edge of material.** The workpiece may split causing the fastener to ricochet, injuring you or a co-worker. Be aware that the nail may follow the grain of the wood (shiner), causing it to protrude unexpectedly from the side of the work material. Drive the nail perpendicular to the grain to reduce risk of injury.

**Do not drive nails onto the heads of other fasteners or with the tool at too steep an angle.** Personal injury from strong recoil, jammed fasteners, or ricocheted nails may result.

**Be aware of material thickness when using the nailer.** A protruding nail may cause injury.

**Be aware that when the tool is being utilized at pressures on the high end of its operating range, nails can be driven completely through thin or very soft work material.** Make sure the pressure in the compressor is set so that nails are set into the material and not pushed completely through.

**Keep hands and body parts clear of immediate work area.** Hold workpiece with clamps when necessary to keep hands and body out of potential harm. Be sure the workpiece is properly secured before pressing the nailer against the material. The contact trip may cause the work material to shift unexpectedly.

**Do not use tool in the presence of flammable dust, gases or fumes.** The tool may produce a spark that could ignite gases causing a fire. Driving a nail into another nail may also cause a spark.

**Keep face and body parts away from back of the tool cap when working in restricted areas.** Sudden recoil can result in impact to the body, especially when nailing into hard or dense material.

**Grip tool firmly to maintain control while allowing tool to recoil away from work surface as fastener is driven.** With the contact trip (black) trigger assembled, if contact trip is allowed to recontact work surface before trigger is released an unwanted fastener will be driven.

**Choice of triggering is important.** Check the manual for triggering options. Refer to Trigger Operation under the Operation section.

**DEPTH ADJUSTMENT: To reduce risk of serious injury from accidental actuation when attempting to adjust depth, ALWAYS:**

- Disconnect air supply.
- Avoid contact with trigger during adjustments.



**WARNING:** Some dust created by power sanding, sawing, grinding, drilling, and other construction activities contains chemicals known to the State of California to cause cancer, birth defects or other reproductive harm. Some examples of these chemicals are:

- Lead from lead-based paints,
- Crystalline silica from bricks and cement and other masonry products, and
- Arsenic and chromium from chemically-treated lumber.

Your risk from these exposures varies, depending on how often you do this type of work. To reduce your exposure to these chemicals: work in a well-ventilated area, and work with approved safety equipment, such as those dust masks that are specially designed to filter out microscopic particles.



**WARNING: ALWAYS USE SAFETY GLASSES.** Everyday eyeglasses are NOT safety glasses. Also use face or dust mask if operation is dusty. **ALWAYS WEAR CERTIFIED SAFETY EQUIPMENT:**

- ANSI Z87.1 eye protection (CAN/CSA/Z94.3),
- ANSI S12.6 (S3.19) hearing protection,
- NIOSH/OSHA/MSHA respiratory protection.

# KNOWING YOUR FRAMING NAILER

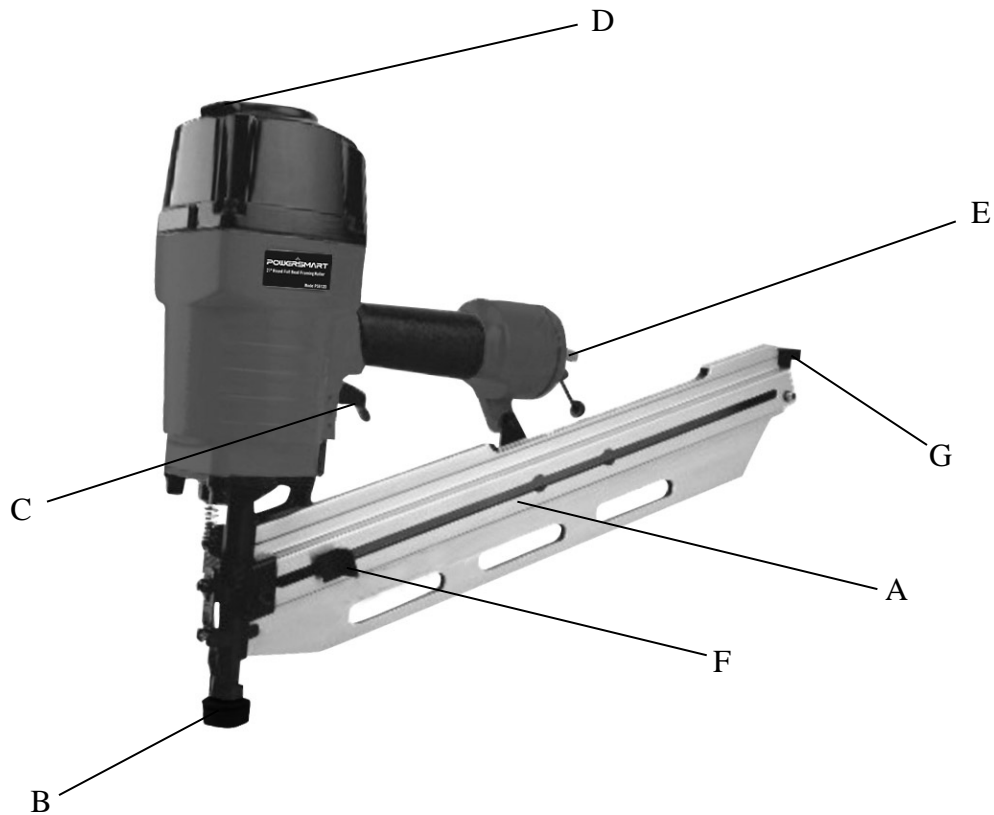

A	Magazine	C	Trigger
B	Safety contact trip	D	Exhaust deflector
E	1/4" Air quick coupler	F	Magazine handle
G	Magazine latch		

## **Unpacking**

Unpack the framing nailer and all its parts, and compare against the list below. Do not discard the carton or any packaging materials. Please call 1-800-791-91458 or E-mail us at [support@amerisuninc.com](mailto:support@amerisuninc.com) if any parts are damaged or missing.

### **Including:**

1 – Framing nailer, one of Hex wrenches 2mm, 3mm,4mm,5mm, 1 - Safety glasses, 1 - User manual, 1 - bottle of oil, 1 - 1/4 Air inlet (assembled on product) and 1 - Carrying case.



## ASSEMBLY



**WARNING:** Disconnect air line from tool and remove fasteners from magazine before making adjustments or personal injury may result.

### **AIR FITTING**

This tool uses a 1/4" N.P.T. male plug. The inside diameter should be 0.180" (4.6 mm) or larger. The fitting must be capable of discharging tool air pressure when disconnected from the air supply.



**WARNING:** Always use couplings that relieve all pressure from the tool when it is disconnected from the power supply. Always use hose connectors that shut off air supply from compressor when the tool is disconnected.

### **TO INSTALL AN AIR FITTING**

1. Wrap the male end of the fitting with thread seal tape prior to assembly to eliminate air leaks.
2. To install a 1/4" (6.4 mm) fitting: screw it directly into the air inlet and tighten firmly. **NOTE:** If an adapter is in the air inlet, remove it prior to inserting the fitting.

## OPERATING INSTRUCTION



**WARNING:** Read and thoroughly understand all instructions and safety information before operating this framing nailer. Failure to do so may cause serious injury or death. Do not allow anyone to operate this framing nailer who has not read this manual. a framing nailer can be dangerous if assembled or used improperly. Do not operate this framing nailer if you have doubts or questions concerning safe operation. Call our customer service department at 1-800-791-9458 to address these concerns.



**WARNING:** Always wear safety glasses, safety gloves, safety shoes and suitable work clothing when operating this impact wrench. Do not wear jewelry, neckties or other loose clothing which could get caught in moving parts

PowerSmart PS6120 Pneumatic Framing nailer drives 21-degree round head framing nails from 2" to 3-1/2" (50 mm to 90 mm) in length. The tool has a die cast aluminum body for strong and light weight design. The tool features a comfortable rubber handle for improved control and comfort even during extended use and a contact safety to prevent accidental firing and an adjustable depth for various applications.

## Loading



**WARNING:** Keep the tool pointed away from yourself and others. Serious personal injury may result.



**WARNING:** Never load nails with the contact trip or trigger activated. Personal injury may result.

When replacing nails in your model PS6120, follow these guidelines:

Nail Type: 21 degree round head framing nail

Length: 2"-3 1/2"

Diameter: 0.113" – 0.130"

Capacity: 60 pcs

### To load your nailer:

1. Disconnect nailer from the air supply!
2. Slide the magazine back, as shown in Figure 1, until it locks in place.
3. Insert a strip of nails, pointed-end down, into the magazine as shown in Figure 2.
4. Slide the nails all the way down to the nose of the nailer.
5. With one hand on the magazine handle for control, release the magazine catch and slowly allow the magazine to press against the nails. **Note:** Releasing the magazine catch and allowing it to “snap” in position is hard on the nailer.

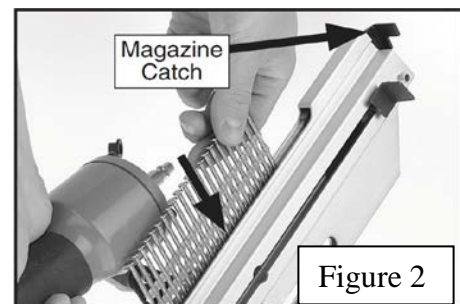
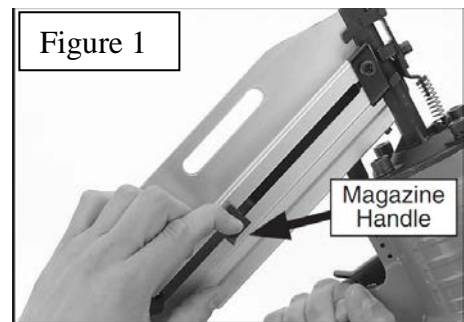

### To operate your nailer:

**If you have not read the safety instructions in this manual, do not operate the nailer.**

Before you operate your nailer, place five to six drops of the included oil the quick connect fitting where the nailer connects to the air supply.

1. Connect the air supply to the quick connect coupler.
2. To test for proper nail penetration, hold the nailer perpendicular to the surface of a piece of clean scrap wood that is thick enough for the length of nails you have loaded.
3. Depress the safety nose mechanism against your workpiece.
4. Before pulling the trigger, make sure your free hand and other body parts are positioned out of the way of a potential path of a nail in case of deflection. Deflection is caused when grain irregularities, knots or foreign objects inside the wood cause the nail to change its path, resulting in the nail puncturing the surface of the workpiece. Besides damaging your workpiece, deflection can cause injury if your free hand is securing the workpiece in the location that the nail deflects.

- Pull the trigger.
  - If the nail drove into the wood for enough, continue with your intended operations.
  - If the nail either went too far or not far enough, then refer to Adjusting Depth subsection.



**WARNING:** During operation, this nailer can propel objects into the air and exhaust concentrated bursts of air, causing immediate eye damage. To reduce your risk from these hazards, always wear ANSI approved safety glasses or a face shield.



**WARNING:** Never point this nailer at yourself or another person! Always pay attention to the direction this nailer is pointed to reduce the risk of serious injury.

## Adjusting Depth

A depth adjustment device is attached to the nose for setting the nail depth.

To adjust the depth:

- Disconnect nailer from the air supply!
- Loosen the cap screw on the depth adjustment device(Figure 3), and move the safety nose backward to increase the nail depth or forward to decrease the nail depth.
- Connect nailer to the air supply, test the nail depth, and repeat this entire procedure if necessary until the nail depth is satisfactory.

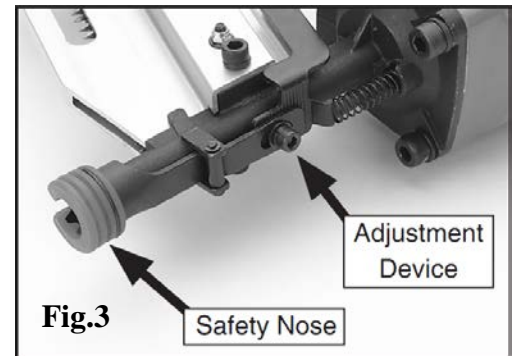

## Clearing Jammed Nails

A jammed nail must be cleared before using the nailer again.

To clear a jammed nail from the discharge area:

- Disconnect nailer from the air supply!
- Pull the magazine handle all the way back until it latches.
- Remove the nail stick from the magazine.
- Locate the opening in the underside of the nailer nose (Figure 4).
- Dislodge the jammed nail with a tool that will fit in the slot on the underside of the nose, such as needle nose pliers.
- Throw the damaged nail away and insert a new nail stick that only contains clean, undamaged nails. **DO NOT** use dirty or damaged nails!



## Cleaning

Use a good solvent to clean the nose assembly of the nailer. Always be sure that the nailer is dry before using it again.

Do not allow dust, chips, sand, etc. into the air connectors or into the body of the nailer; this may result in leaks and damage to the nailer and the air couplings.



**WARNING:** Never use gasoline or other flammable liquids to clean this tool. Vapors in the tool may ignite, causing the tool to explode. Ignoring this warning may lead to serious personal injury or even death!

## Air supply

- Use clean, Dry and regulated compressed air at 80-120 PSI (5.5-8bar).

2. Never exceed maximum and minimum pressure. Too low or too high pressure would cause noise wear and tear or misfiring.
3. When connecting air supply always keep hands and body away from discharge area of tool.
4. A filter- regulator-lubrication is required and should be located as close to tool as possible.
5. Keep air filter clean. A dirty filter will reduce the air pressure to the tool causing a reduction in power and efficiency.
6. For better performance, install a quick connector in your tool and quick coupler on the hose if possible.
7. Be sure all connections in air supply system are sealed to prevent air loss.

If you plan on installing a filter/ lubricator/regulator unit in your compressed air system, always follow the connection instructions that come with the unit.

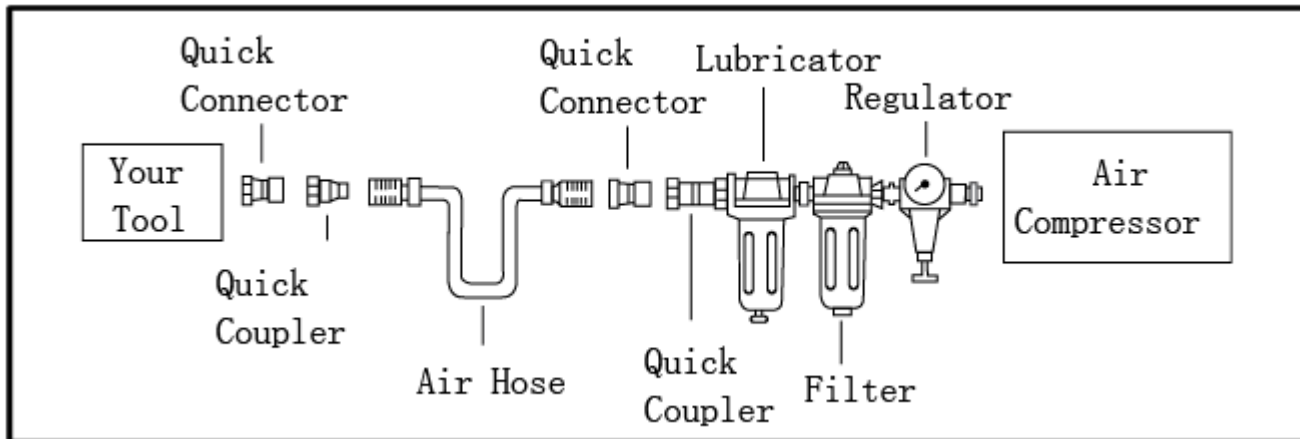

**Typical filter/ lubricator/regulator installation order.**



**WARNING:** Exceeding the maximum permissible operating pressure may cause the nailer to explode, blowing metal fragments in all directions. To protect yourself from serious personal injury, DO NOT allow your air compressor to exceed the recommended pressure when connected to this nailer!

## MAINTENANCE



**WARNING:** Disconnect the tool from the air compressor before adjusting, clearing jams, servicing, Relocating and during non-operation.

1. Regular lubrication of the tool is required. Add 2 to 6 drops of lubricant oil into the air inlet before each work day or after 2 hours of continuous use depending on the characteristic of work piece or type of fasteners.
2. Check and change all worn or damaged o-rings, seals, etc. Tighten all the screws and caps to avoid personal injury.
3. Inspect trigger and safety mechanism to assure system is complete and functional with no loose or missing parts.
4. Keep magazine and workpiece contact trip clean and free of any dirt lint or abrasive particles.

## **TROUBLE SHOOTING**

The following form lists the common operating system with problem and solutions. Please read the form carefully and follow it.



**WARNING:** If any of the following symptoms appears during your operating, stop using the tool immediately, or serious personal injury could result. Only a qualified persons or an authorized service center can perform repairs or replacement of tool.

Disconnect tool from air supply before attempting repair or adjustment. When replacing O-rings or Cylinder, lubricate with air tool oil before assembly.

PROBLEMS	POSSIBLE CAUSES	REMEDIES
Air leak near top of tool or in trigger	<ol style="list-style-type: none"> <li>1. O-ring in trigger valve are damaged.</li> <li>2. Trigger valve head are damage.</li> <li>3. Trigger valve stem, seal or O-ring are damaged.</li> </ol>	<ol style="list-style-type: none"> <li>1. Check and replace O-ring.</li> <li>2. Check and replace.</li> <li>3. Check and replace trigger valve stem, seal or O-ring</li> </ol>
Air leak near bottom of tool.	<ol style="list-style-type: none"> <li>1. Loose screws.</li> <li>2. Worn or damaged O-rings or bumper.</li> </ol>	<ol style="list-style-type: none"> <li>1. Tighten screws.</li> <li>2. Check and replace O-rings or bumper.</li> </ol>
Air leak between body and cylinder cap.	<ol style="list-style-type: none"> <li>1. Loose screws.</li> <li>2. Worn or damaged O-rings or seals.</li> </ol>	<ol style="list-style-type: none"> <li>1. Tighten screw.</li> <li>2. Check and replace O-rings or bumper.</li> </ol>
Blade driving fastener too deep.	<ol style="list-style-type: none"> <li>1. Worn bumper.</li> <li>2. Air pressure is too high.</li> </ol>	<ol style="list-style-type: none"> <li>1. Replace bumper.</li> <li>2. Adjust the air pressure.</li> </ol>
Tool does not operate well: can not drive fastener or operate sluggishly.	<ol style="list-style-type: none"> <li>1. Inadequate air supply.</li> <li>2. Inadequate lubrication.</li> <li>3. Worn or damaged O-rings or seals.</li> <li>4. Exhaust port in cylinder head is blocked.</li> </ol>	<ol style="list-style-type: none"> <li>1. Verify adequate air supply.</li> <li>2. Place 2 or 6 drops of oil into air inlet.</li> <li>3. Check and replace O-rings or seal.</li> <li>4. Replace damaged internal parts.</li> </ol>
Tool skips fasteners.	<ol style="list-style-type: none"> <li>1. Worn bumper or damaged spring.</li> <li>2. Dirt in front plate.</li> <li>3. Dirt or damage prevents fasteners from moving freely in magazine.</li> <li>4. Worn or dry O-ring on piston or lack of Lubrication.</li> <li>5. Cylinder cover seal leaking.</li> </ol>	<ol style="list-style-type: none"> <li>1. Replace bumper or pusher spring.</li> <li>2. Clean drive channel on front plate.</li> <li>3. Magazine needs to be cleaned.</li> <li>4. O-ring needs to be replaced. And lubricate.</li> <li>5. Replace Sealing washer.</li> </ol>
Tool jams.	<ol style="list-style-type: none"> <li>1. Incorrect or damaged fasteners.</li> <li>2. Damaged or worn driver guide.</li> <li>3. Magazine or nose screw loose.</li> <li>4. Magazine is dirty.</li> </ol>	<ol style="list-style-type: none"> <li>1. Change and use correct fastener.</li> <li>2. Check and replace the driver.</li> <li>3. Tighten the magazine.</li> <li>4. Clean the magazine.</li> </ol>

Note: Repairs should be carried out by a qualified person.

## **EXPLODED VIEW & PARTS LIST**

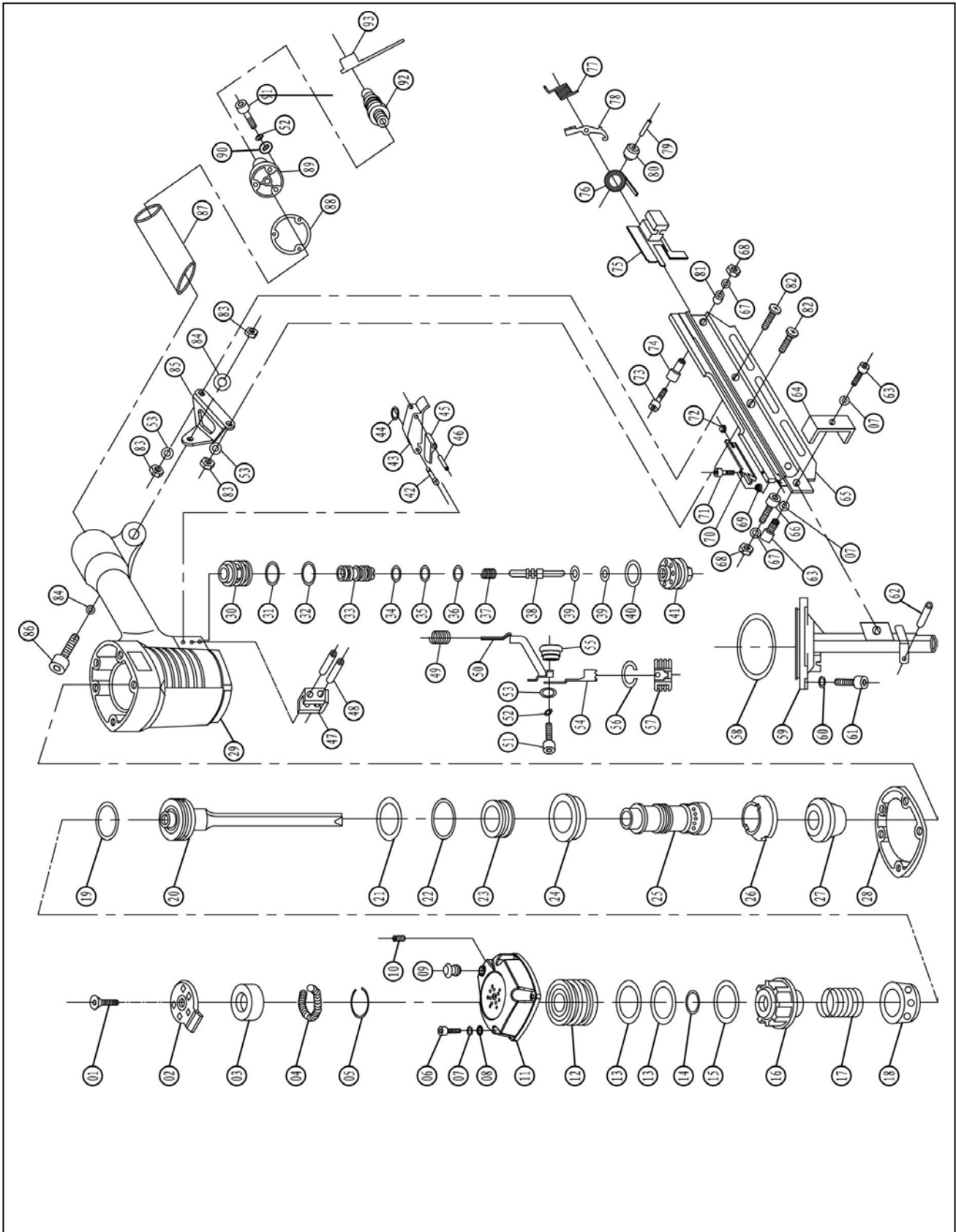

Item	Stock #	Description	Qty
1	PS6120-001	Bolt M8x16	1
2	PS6120-002	Exhaust deflector	1
3	PS6120-003	Deflector rubber	1
4	PS6120-004	Compression spring	1
5	PS6120-005	Spring wire	1
6	PS6120-006	Bolt M6x30	4
7	PS6120-007	Spring washer 6	6
8	PS6120-008	Flat washer 6	4
9	PS6120-009	Cylinder core	1
10	PS6120-010	Bolt M5x5	1
11	PS6120-011	Cylinder cover	1
12	PS6120-012	Head valve piston	1
13	PS6120-013	O-ring 56x3.1	2
14	PS6120-014	O-ring 41.7x3	1
15	PS6120-015	Spring washer	1
16	PS6120-016	Spring seat	1
17	PS6120-017	Compression spring	1
18	PS6120-018	Collar	1
19	PS6120-019	O-ring 42.5x5	1
20	PS6120-020	Piston assembly	1
21	PS6120-021	O-ring 57.5x3	1
22	PS6120-022	O-ring 88x3	1
23	PS6120-023	Fixed ring	1
24	PS6120-024	Sealing ring	1
25	PS6120-025	Cylinder	1
26	PS6120-026	Bumper outer lane	1
27	PS6120-027	Bumper	1
28	PS6120-028	Cylinder gasket	1
29	PS6120-029	Housing	1
30	PS6120-030	Trigger valve seat	1
31	PS6120-031	O-ring 15x2.65	1
32	PS6120-032	O-ring 16x1.6	1
33	PS6120-033	Trigger valve guide	1
34	PS6120-034	O-ring 6.1x1.8	1
35	PS6120-035	O-ring 6.4x2	1
36	PS6120-036	O-ring 9x1.8	1
37	PS6120-037	Switch spring	1
38	PS6120-038	Switch pipe	1
39	PS6120-039	O-ring 2.4x1.6	2
40	PS6120-040	O-ring 18x2.65	1
41	PS6120-041	Switch seat	1
42	PS6120-042	Roll pin	1
43	PS6120-043	Trigger	1
44	PS6120-044	O-ring 1.7x2	1
45	PS6120-045	Safety spacer	1
46	PS6120-046	Roll pin 3x16	1
47	PS6120-047	Safety guide	1
48	PS6120-048	Pin 3x26	2

Item	Stock #	Description	Qty
49	PS6120-049	Compression spring	1
50	PS6120-050	Safety yoke	1
51	PS6120-051	Bolt M5x10	1
52	PS6120-052	Spring washer 5	4
53	PS6120-053	Flat washer 5	3
54	PS6120-054	Safety nose	1
55	PS6120-055	Depth adjustment nut	1
56	PS6120-056	Copper collar	1
57	PS6120-057	Safety nose case	1
58	PS6120-058	O-ring 59x1.8	1
59	PS6120-059	Drive guide	1
60	PS6120-060	Spring washer	4
61	PS6120-061	Bolt M8x25	4
62	PS6120-062	Pin 3x18	1
63	PS6120-063	Bolt M6x12	2
64	PS6120-064	Plate	1
65	PS6120-065	Magazine	1
66	PS6120-066	Bolt M4x8	1
67	PS6120-067	Washer 4	2
68	PS6120-068	Nut M4	2
69	PS6120-069	Washer case	1
70	PS6120-070	Drive nail bar	1
71	PS6120-071	Bolt M3x4	1
72	PS6120-072	Spacer	2
73	PS6120-073	Bolt M4x42	1
74	PS6120-074	Safety pipe	1
75	PS6120-075	Magazine handle	1
76	PS6120-076	Spring	1
77	PS6120-077	Latch spring	1
78	PS6120-078	Magazine latch	1
79	PS6120-079	Pin B4x25	1
80	PS6120-080	Spring core	1
81	PS6120-081	Safety pipe case	1
82	PS6120-082	Bolt M5x14	2
83	PS6120-083	Nut M5	3
84	PS6120-084	Washer 5	2
85	PS6120-085	Fixed seat	1
86	PS6120-086	Bolt M5x25	1
87	PS6120-087	Rubber grip	1
88	PS6120-088	End cap washer	1
89	PS6120-089	End cap	1
90	PS6120-090	Flat washer	3
91	PS6120-091	Bolt M5x20	3
92	PS6120-092	Air inlet plug	1
93	PS6120-093	Air inlet plug cover	1

## **TWO (2) YEARS LIMITED WARRANTY**

PowerSmart® is committed to building tools that are dependable for years. Our warranties are consistent with our commitment and dedication to quality.

### **TWO (2) YEARS LIMITED WARRANTY OF POWER SMART PRODUCTS FOR HOME USE.**

PowerSmart ("Seller") warrants to the original purchaser only, that all PowerSmart consumer power tools will be free from defects in material or workmanship for a period of two (2) years from date of purchase. Ninety (90) days for all Power Smart Products, if the tool is used for professional or commercial use.

**SELLER'S SOLE OBLIGATION AND YOUR EXCLUSIVE REMEDY** under this Two (2) Years Limited Warranty and, to the extent permitted by law, any warranty or condition implied by law, shall be the repair or replacement of parts, without charge, which are defective in material or workmanship and which have not been misused, carelessly handled, or misrepaired by persons other than Seller or Authorized Service Center. To make a claim under this Limited Warranty, you must return the entire power tool product; transportation prepaid, to Power Smart Include a legible copy of the original receipt, which lists the date of purchase (month and year) and the name of the company purchased from.

**THIS LIMITED WARRANTY DOES NOT APPLY TO ANY ACCESSORY ITEMS INCLUDED WITH THE TOOL SUCH AS CIRCULAR SAW BLADES OTHER RELATED ITEMS OR TO ANY REPLACEMENT PARTS LISTED UNDER MAINTENANCE.**

**ANY IMPLIED WARRANTIES SHALL BE LIMITED IN DURATION TO TWO (2) YEARS FROM DATE OF PURCHASE. SOME STATES IN THE U.S. AND SOME CANADIAN PROVINCES DO NOT ALLOW LIMITATIONS ON HOW LONG AN IMPLIED WARRANTY LASTS, SO THE ABOVE LIMITATION MAY NOT APPLY TO YOU.**

**IN NO EVENT SHALL SELLER BE LIABLE FOR ANY INCIDENTAL OR CONSEQUENTIAL DAMAGES (INCLUDING BUT NOT LIMITED TO LIABILITY FOR LOSS OF PROFITS) ARISING FROM THE SALE OR USE OF THIS PRODUCT. SOME STATES IN THE U.S. AND SOME CANADIAN PROVINCES DO NOT ALLOW THE EXCLUSION OR LIMITATION OF INCIDENTAL OR CONSEQUENTIAL DAMAGES, SO THE ABOVE LIMITATION OR EXCLUSION MAY NOT APPLY TO YOU.**

**THIS LIMITED WARRANTY GIVES YOU SPECIFIC LEGAL RIGHTS, AND YOU MAY ALSO HAVE OTHER RIGHTS WHICH VARY FROM STATE TO STATE IN THE U.S., PROVINCE TO PROVINCE IN CANADA AND FROM COUNTRY TO COUNTRY.**

For questions / comments, technical assistance or repair parts –  
Please call toll free at: 1-800-791-9458 (M-F 9am – 5pm EST)  
Email: support@amerisuninc.com

**SAVE YOUR RECEIPTS. THIS WARRANTY IS VOID WITHOUT THEM.**