



USER MANUAL

Copyright AMETEK Inc. 2006

**AMETEK Lloyd Instruments Ltd
Forum House
12 Barnes Wallis Road
Segensworth East
Fareham
Hampshire
UK
PO15 5TT**

**Tel: +44 (0) 1489 486399
Fax: +44 (0) 1489 885118
Email: techsupport@ametek.co.uk
Internet: www.lloyd-instruments.co.uk**

February 2006.

**User Manual: Part No: 01/3085
Version: 2.0**

For use with all LF *Plus* machines



International Symbols

Caution! Refer to this manual before using your
LFPlus Universal Test Machine

CAUTION

**HIGH FORCES ARE OFTEN INVOLVED WITH THE
MATERIAL TESTING PROCESSES.**

THE MACHINE IS POWERED BY MAINS SUPPLY VOLTAGE

**TO MAINTAIN ALL ASPECTS OF THE SPECIFICATION,
ONLY LLOYD INSTRUMENTS APPROVED ACCESSORIES
CONNECTIONS AND COMPONENTS SHOULD BE USED**

**STRICTLY ADHERE TO ALL SPECIFIED SAFETY
PROCEDURES**

**READ THIS MANUAL BEFORE USING THE TESTING
MACHINE**



International Symbols

WEEE Directive

**This equipment contains Electrical and Electronic
circuits and should not be directly disposed of in
a landfill site.**

CE DECLARATION OF CONFORMITY

Printed below is a copy of an AMETEK Lloyd Instruments declaration that the *LFPlus* you have meets the requirements for CE marking. Actual copies of the certificate for your type of *LFPlus* may be obtained from AMETEK Lloyd Instruments

DECLARATION OF CONFORMITY

NAME AND ADDRESS OF MANUFACTURER

AMETEK Lloyd Instruments Ltd.,
Forum House,
Barnes Wallis Road,
Segensworth East,
Fareham,
Hampshire,
PO15 5TT
ENGLAND.

DESCRIPTION OF EQUIPMENT

Materials Testing System model *LFPlus*

DIRECTIVES COMPLIED WITH

LOW VOLTAGE DIRECTIVE (73/23/EEC) ('LVD')
EMC DIRECTIVE (89/336/EEC) ('EMC')

HARMONISED STANDARDS USED

BS EN 61010 - 1: 1993
BS EN 50081 - 1: 1992
BS EN 50082 - 1: 1992

IDENTIFICATION OF SIGNATORY

KEVIN KIRBY
Product Development Manager

..........DATE 05/08/2001

CONTENTS

1.0	INTRODUCTION	1
1.1	INTRODUCTION.....	1
1.2	SAFETY.....	3
2.0	ELECTRICAL SAFETY	4
2.1	ELECTRICAL SAFETY.....	4
3.0	INSTALLATION.....	6
3.1	UNPACKING	6
3.2	SETTING UP YOUR MACHINE	6
3.3	EXTENDED MACHINES	7
3.4	VOLTAGE SELECTION	8
3.5	COMPUTER AND OTHER CONNECTIONS	10
3.6	ON-OFF SWITCH	11
3.7	FITTING THE LOAD CELL.....	11
3.8	ADDITIONAL LOAD CELLS.....	11
3.9	SETTING UP POGO LF <i>Plus</i>	12
4.0	LOAD CELLS	14
4.1	CARE OF LOAD CELLS.....	14
4.2	FITTING LOAD CELLS	14
4.3	GENERAL PRECAUTIONS.....	16
5.0	ACCESSORIES	18
5.1	EXPANDED TABLE.....	18
5.2	T SLOT TABLE.....	20
5.3	DRIP TRAY.....	22
6.0	CONTROL PANEL	23
6.1	CONTROL PANEL DESCRIPTION.....	23
6.2	KEYPAD OPERATION AND DESCRIPTION.....	23
6.3	THE DISPLAY	26
6.4	“SWITCH-ON” DISPLAY	26
7.0	OPERATIONAL PRECAUTION	29
7.1	SAFETY.....	29
7.2	EMERGENCY STOP.....	31
7.3	SPLINTER SHIELDS.....	31
7.4	LOWER ANCHOR PIN ADJUSTMENT	32
7.5	LIMIT STOPS	33

CONTENTS

8.0	PERFORMING A TEST	35
8.1	PERFORMING A TEST	35
8.2	TEST PARAMETERS	35
8.3	SELECTING A TEST	36
8.4	STARTING A TEST	40
8.5	STOPPING A TEST	41
8.6	PRINTING TEST RESULTS	41
8.7	CANCELING OR ACCEPTING THE RESULTS	41
8.8	VIEWING THE STATISTICS	42
8.9	ERROR CONDITIONS	43
9.0	SETTING UP A NEW TEST	44
9.1	PRE-DEFINED TEST SETUPS	44
9.2	DEFAULT GLOBAL SETTINGS	46
9.3	EDITING A PRE-DEFINED TEST SETUP	46
9.4	PASSWORD ACCESS	46
9.5	RENAMING A TEST	47
9.6	DELETING A TEST	47
9.7	GLOBAL SETTINGS	48
9.8	SETTING A PASSWORD	48
9.9	SAFETY LOAD LIMIT	49
9.10	SLOW JOG SPEED	49
9.11	SETTING FOR PRINTER	49
9.12	GRIP PROTECTION SETTINGS	50
9.13	CURRENT LANGUAGE	50
9.14	MACHINE STIFFNESS	50
9.15	TEST SETUP DISPLAY	51
9.16	TEST TYPE	52
9.17	SELECTING MACHINE STIFFNESS COMPENSATION	55
9.18	TEST OPTIONS	55
9.19	TEST RESULTS	58
9.20	PASS/FAIL VALUES	58
9.21	DEFINING SAMPLE	59
9.22	PRE-TEST QUESTIONS	60
10.0	ERROR CONDITION	61
10.1	ERROR CONDITIONS	61

CONTENTS

11.0	CLEANING AND MAINTENANCE	64
11.1	CLEANING EXTERNAL FINISH AND TRIM	64
11.2	MAINTENANCE.....	64
12.0	TECHNICAL SPECIFICATION.....	65
12.1	TECHNICAL SPECIFICATION LFPLUS	65
12.2	TECHNICAL SPECIFICATION LFPLUS EXTENDED	66
12.3	OVERALL DIMENSIONS LF <i>Plus</i>	67
12.4	RS232 LEADS	69

1.0 INTRODUCTION

1.1 INTRODUCTION



LFPlus

Welcome to your new *LFPlus* series advanced, single column, universal testing machine. It incorporates an extensive range of features making it ideal for performing complex testing applications. The machine is microprocessor controlled and uses world proven 32 bit technology for highly accurate load measurement and rapid data acquisition. The integral user interface consists of a control console with large, positive action membrane switches, allowing complex tests to be performed at the touch of a button. A large, back lit Liquid Crystal Display shows the test and set-up information in multi-lingual, multi-unit format.

1.0 INTRODUCTION

The stand alone system is capable of storing up to 600 test results from a choice of 10 user programmable test set-ups, or may be connected via its RS232 output to a personal computer running **NEXYGEN™** FM and **NEXYGEN™** MT, providing almost unlimited testing capability and result manipulation facilities.

The high stiffness frame incorporates a crosshead guidance system to prevent side loading of the sample under test. The crosshead is driven by single lead screw, motor and DC servo system to achieve a wide speed range over the full load range. The machine is capable of running full load at full speed. A range of highly accurate, interchangeable loadcells are available for tension, compression and cycling through zero force measurements. The system is ideal for use in production, quality control, educational and research environments.

All *LFPlus* series systems are designed to meet a broad range of applications. This is achieved mainly through the embedded control software and easily configurable data acquisition software, available as an optional extra. **NEXYGEN™** software is fully **WINDOWS™** compliant and compatible, it seamlessly integrates with contemporary **MICROSOFT™** Office programs using OLE2 technology. The program is easy to use, making use of drop down windows prompts, drag and drop, cut and paste routines. Data can easily be exported to programs such as **EXCEL®**, **ACCESS®**, **OUTLOOK®** and **POWERPOINT®** for further manipulation, and enhanced presentation. **NEXYGEN™** software contains a library of pre-programmed test setups for conducting fully automated tests, in accordance with international standards.

For advice and information about the **NEXYGEN™** data analysis and applications software, please contact your authorized **LLOYD INSTRUMENTS** Sales Representative.

1.0 INTRODUCTION

1.2

SAFETY



Materials testing machines are very safe to use providing the instructions presented in this manual are followed precisely. We would like to draw your attention to both the Electrical Safety (Section 2.0 page 4) and Operational Precautions, (Section 7.0 page 29). Please refer to both sections for details on safe operation of this equipment before operating your materials testing machine.

Transparent splinter shields are available as an option to enclose the test sample if there is any danger of samples shattering as a result of the test. These shields have an electronic interlock such that the test cannot be started until the hinged shield is closed. While not mandatory for many applications and countries, AMETEK Lloyd Instruments Ltd. strongly recommends that users consider fitting this option.

2.0 ELECTRICAL SAFETY

2.1 ELECTRICAL SAFETY

1. The *LFPlus* Universal Test Machine has been designed to meet the requirements of BS EN 61010-1 : 1993 Safety requirements for electrical equipment for measurement, control and laboratory use.
2. The User Manual contains some information and warnings, which have to be followed by the user to ensure safe operation and to keep the machine in safe condition.
3. The machine has been designed for indoor use. It may occasionally be subjected to temperatures between -10°C and +5°C (14°F and 41°F) without degradation of its safety.
4. Before switching on the machine make sure that it is set to the voltage of the mains electricity supply.
5. This machine complies with electrical safety grade Class 1, which means that it is “earthed apparatus” and requires the mains plug to contain a protective earth terminal. The mains plug must only be inserted in a socket outlet provided with a protective earth contact. The protective action must not be negated by the use of an extension cord without a protective conductor.
6. Make sure that only fuses with the required rated current and of the specified type are used for replacement. The use of makeshift fuses and the short-circuiting of fuse holders is prohibited.
7. There are no user serviceable parts within the machine.
8. The machine must be disconnected from all voltage sources before it is opened for any adjustments, replacement, maintenance or repair.

2.0 ELECTRICAL SAFETY

9. Capacitors inside the machine may still be charged even if the machine has been disconnected from all voltage sources.
10. Any adjustment, maintenance or repair of the opened machine connect to the mains supply voltage should be avoided as far as possible but if inevitable, must only be carried out by a skilled person who is aware of the hazard involved.

3.0 INSTALLATION

3.1 UNPACKING

The *LFPlus* on its own, without the packing and accessories weighs more than 46kg (102lb). Therefore, safe lifting practices should be employed and lifting equipment used as necessary.

The machine is packed lying on its back and should be delivered to you this way up. Open the 2 long lid flaps of the box if the machine has been delivered to you packed in cardboard or remove the lid to the crate if packed in wood and stand the packing box / crate on its end with the base of the machine down and the column facing up. Slide the machine out of the packing still sitting in its foam mouldings. Remove the top foam moulding and use 2 people to lift the *LFPlus* out of the bottom foam moulding.

Please make a careful visual inspection of all the parts made to ensure that there is no obvious transit damage.

Please check that you have received all the parts that were ordered.

If there is any damage, or parts missing, please report them to your authorised LLOYD INSTRUMENTS representative.

3.2 SETTING UP YOUR MACHINE

The *LFPlus* Materials Testing Machine is a heavy item and great care should be taken in choosing the location where it is to be installed. Ensure the bench is capable of remaining firm and stable, withstanding the combined weight of the machine and any accessories supplied. Please see the Specification page at the end of this manual for the weight of the apparatus. The machine must be vertical, otherwise the results may be affected, particularly for very low loads.

3.0 INSTALLATION

The machine can be levelled by means of the 4 adjustable feet. Loosen the lock nuts on each foot and adjust the feet until the machine is vertical when viewed from the front and the side. When level re-tighten the lock nuts.



CAUTION:- Care must be taken not to block the ventilation holes in the side of the *LFPlus*. Leave a minimum of 100mm (4 inch) clearance on the left side of the machine.



CAUTION:- At no time should the *LFPlus* be lifted by placing hands under the frame feet.

The *LFPlus* must be positioned such that the front can be easily accessed, and that the emergency stop button is not obstructed in any way. Please ensure utmost care is taken when lifting this instrument, **use safe working practices**. Lifting equipment should be used as necessary. The two recommended methods are described below:

1. Lifting with a pallet. A pallet may be fitted under the machine so it may be lifted to the desired position with a forklift or a suitable lifting trolley.
2. By hand. The machine can be lifted manually, at least 2 people should be employed to do this as the machine weighs more than 46kg (102lb).

3.3

EXTENDED MACHINES

The extended (longer travel) *LFPlus* machines are supplied with 2 clamps which are designed to increase the stability of extended machines.

In order to comply with the machine stability requirements of EN61010 it is necessary to restrain the base of the extended version of the machine to the working surface. The procedure is as follows;-

3.0 INSTALLATION

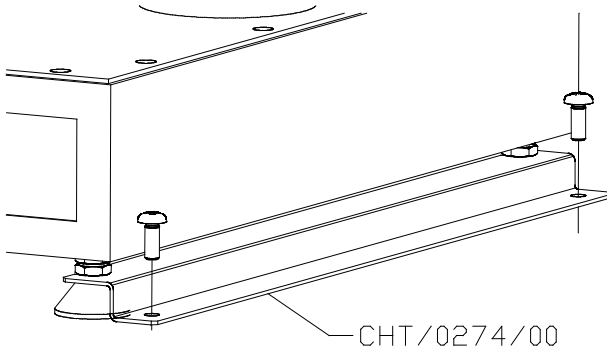

Clamping Extended Machine To The Bench

1. Position and level machine on the working surface/bench.
2. Position the two clamp bars, (Part No CHT/0274/00, part of 07/2170) as shown, with the slots located over the base of the feet,
3. Mark the position of the 6mm diameter fixing holes (2 in each bar) on to the working surface. Remove the bars.
4. At the marked positions, drill suitable holes. Refit the bars and with suitable fixings secure the bars to the bench. Due to the variety of mounting surfaces, the fixings are not included and should be purchased locally to suit your requirements.

3.4 VOLTAGE SELECTION

The *LFPlus* can be used with electricity supplies of either 230Vac $\pm 10\%$ or 115Vac $\pm 10\%$. The power input cable should be inserted at the rear of the machine. Before switching on the machine you **MUST** check the correct voltage has been selected on the mains input connector. Ensure that the selection is correct for the voltage of your power supply.

3.0 INSTALLATION

To change the voltage setting, unplug the mains lead from the back of the machine and use a screwdriver to open the voltage selector. The screwdriver should then be used to move the selector from the 115V position to the 230V position as appropriate. You **MUST** also check that the fuse rating is suitable for the supply voltage that you are using. The fuses (live and neutral) are located inside the power input connector. The fuses for 230Vac are 1A (T) and for 115Vac 2A (T).

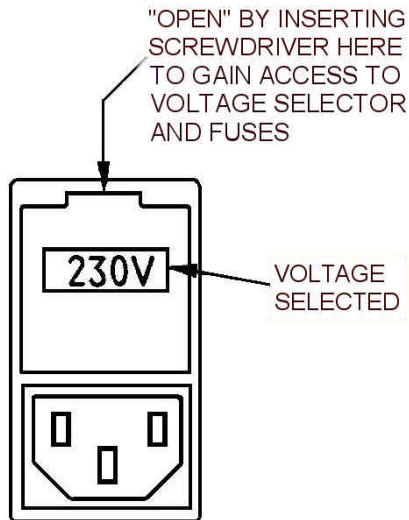

Voltage Selection & Fuses

3.0 INSTALLATION

3.5 COMPUTER AND OTHER CONNECTIONS



Rear Panel Connections LFPlus

Use lead part number 09/0639, supplied in the accessory kit with the *LFPlus*, to connect the machine to a computer.

Connection leads for extensometers and the plotter interface box are supplied with each piece of equipment. These are “Smart Leads” and identify the equipment being connected to the *LFPlus*. It is therefore very important that these leads are kept with the equipment that they are programmed for and not mixed up with any others.



NOTE: To maintain EMC compatibility, only connection leads supplied by LLOYD INSTRUMENTS should be used to connect this equipment to computers and/or accessories.

3.0 INSTALLATION

3.6 ON-OFF SWITCH

The power on switch is located on the machine base at the front left of the main base unit. The switch is a rocker type with positions **O** and **I**. By selecting **I** power will be supplied to the machine.

3.7 FITTING THE LOAD CELL

Before the machine is powered up, or any test set-ups are entered, the Load Cell should be fitted.

Carefully unpack the Load Cell(s) supplied with your machine. Please make **all operators** aware that they are precision load measuring devices and should be treated with great care. **Please read SECTION 4.0 LOAD CELLS before proceeding further.**

3.8 ADDITIONAL LOAD CELLS

The following standard Load Cells are available for your *LFPlus*.

	Description	Part Number
XLC-0005-A1	0.5% accuracy 5N	01/2946
XLC-0010-A1	0.5% accuracy 10N	01/2360
XLC-0020-A1	0.5% accuracy 20N	01/2950
XLC-0050-A1	0.5% accuracy 50N	01/2361
XLC-0100-A1	0.5% accuracy 100N	01/2480
XLC-0250-A1	0.5% accuracy 250N	01/3048
XLC-0500-A1	0.5% accuracy 500N	01/2362
XLC-1000-A1	0.5% accuracy 1000N	01/2419

3.0 INSTALLATION

3.9 SETTING UP POGO LFPlus

AMETEK Lloyd Instruments Limited produces a range of machines that can be mounted on specially designed frames that can be used for testing a wide range of bulky items such as cardboard cartons, crates and furniture.

These “Pogo” machines have a linear bearing fitted in the fixed lower crosshead through which a rod runs, connecting the load cell and the compression platens mounted below the machine within the frame.



LFPlus Pogo mounted on a Carton Crusher Frame.

3.0 INSTALLATION

No specific information about siting an *LFPlus* Pogo can be issued with the machine on it's own because the size and specification of the frame are decided by the customer's specific needs.

The frame should be positioned first and the instructions for set-up and wiring supplied with the frame followed closely.

The *LFPlus* Pogo will have been supplied to you with the frame mountings included.

Because the mountings protrude from the bottom of the *LFPlus*, the machine cannot stand on it's own until it is fitted and secured to the mounting frame.

Suitable lifting equipment should be employed.

The Pogo Rod should be fitted last. Secure the *LFPlus* to the top of the frame as per the instructions supplied with the frame. Insert the rod through the bearing on the lower (fixed) crosshead of the *LFPlus* and connect to the Bottom Platen. Connect to the Loadcell last.

If you need to use the *LFPlus* Pogo as an ordinary machine and not as a Pogo, proceed as follows.

1. Remove the Pogo Rod from the machine and mounting frame.
2. Unscrew the boss containing the linear bearing from the bottom cross head.
3. Screw in the adapter plate in place of the linear bearing boss.
4. Screw the standard bottom anchor pin complete with 2 locking rings into the adapter plate.

Full fitting and wiring instructions are supplied with the Crusher Frame. Fitting and wiring of the Emergency Stop Buttons are designed to meet each customer's specific needs.

4.0 LOAD CELLS

4.1 CARE OF LOAD CELLS

ALL machine operators should be aware that LLOYD INSTRUMENTS' Load Cells are precision force measuring instruments, which should be treated with the utmost care to avoid accidental damage. In particular low force Load Cells are easily damaged if abused or used without sufficient care:

1. Do not submit Load Cells to physical shock of any kind. **DO NOT DROP!**
2. When a Load Cell is removed from a machine immediately put it in a safe and dry place.

4.2 FITTING LOAD CELLS

To install a Load Cell. Place the appropriate adaptor collar in the hole in the moving crosshead.

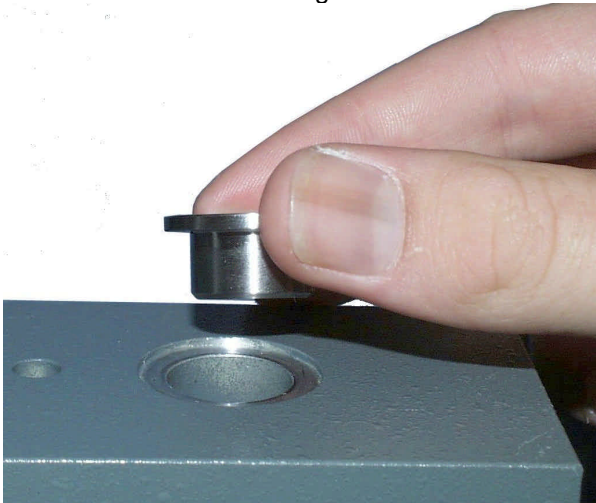

For XLC Load Cells use kit part number SPK/LFM/0002 which includes the necessary bottom anchor pin parts and the lower anchor pin.

4.0 LOAD CELLS

Place the Load Cell fixing screw through the collar and carefully offer up the load cell with the connecting lead facing inwards under the crosshead.

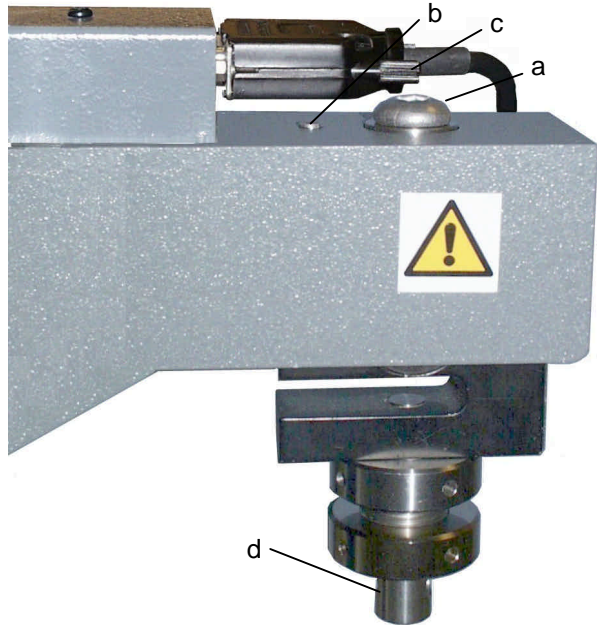

LFPlus Load Cell Fitting

Screw the fixing screw (a) into the load cell, taking care to ensure that the locating dowel (b, when fitted) on the load cell sits in the hole in the moving crosshead. Tighten the screw with the Allen key (Hex key) provided. Insert the load cell plug (c) in the socket on the top of the moving crosshead and finger tighten the two retaining screws. Fit the eye end (d) to the load cell and tighten in the required position with the C spanner supplied.

4.0 LOAD CELLS

4.3 GENERAL PRECAUTIONS

The following points should be considered:

1. When installing the upper grip (particularly heavy ones) on the load cell eye end, avoid bumping the eye end. If the grip is a close fit, **DO NOT FORCE IT**, establish the reason and rectify. Immediately set, or re-set, the bottom limit stop so the grips will not meet when the crosshead is lowered. See section **7.5 LIMIT STOPS**.
2. In both tension and compression tests, centre the specimen in line with the axis of the load cell and the bottom fixed anchoring device or pin to avoid side thrust.
3. In compression tests, care must be taken to avoid bringing the platens together or against solid specimens at high speed. Cells thus damaged cannot be repaired. Ensure that the lower crosshead limit is set correctly. See section **7.5 LIMIT STOPS**.
4. In compression tests, if special lower fixtures are used, ensure that they are fixed in position so they cannot be accidentally moved to block the normal downward movement of the upper fixture, e.g. where a tongue on the upper fixture must fit into a slot in the lower fixture. See section **7.4 LOWER ANCHOR PIN ADJUSTMENT**.
5. Avoid overloading beyond the load cell rated capacity. Prior to testing ensure, if possible, that the maximum force anticipated will not exceed the capacity of the cell installed. If maximum capacity is approached during a test, run the machine at slow speed in local mode, and reverse the crosshead if capacity is exceeded.

4.0 LOAD CELLS

Note:

All machines incorporate overload protection, which will stop the machine if capacity is exceeded in either tension or compression. However, at higher speeds, momentum may carry the crosshead far enough after shut-off to damage the cell. All cells can be damaged this way but in low force cells this distance is very short. Cells thus damaged cannot be repaired.

6. LLOYD INSTRUMENTS load cells are built to exceed the standards as set out by ASTM, BS, DIN etc. All cells on *LFPlus* machines are user-changeable. Various capacities are available from 5N up to the capacity of the frame. While cells may be used below 10% of capacity it is recommended that, when such lower forces are anticipated, a lower force cell be installed such that the test force will fall in the upper 90% of its range. This will give the best signal to noise performance of the load measuring system.

5.0 ACCESSORIES

5.1 EXPANDED TABLE



An extended base table is available to assist with the testing of wider items. There are 2 versions of the extended table which has 25 tapped holes strategically placed for easy anchoring of the part to be tested using customised jigs and fixtures, additional holes may be added by the user, 1 version has M6 tapped holes the other has # 10-32 tapped holes

5.0 ACCESSORIES

The extended table is attached to the *LFPlus* by two M6 socket head screws, which are supplied with it. It is mounted on the bottom anchor pin boss.

EXPANDED TABLE

Two holes for fixing the extended table to the *LFPlus*

25 off tapped holes for attaching fixtures

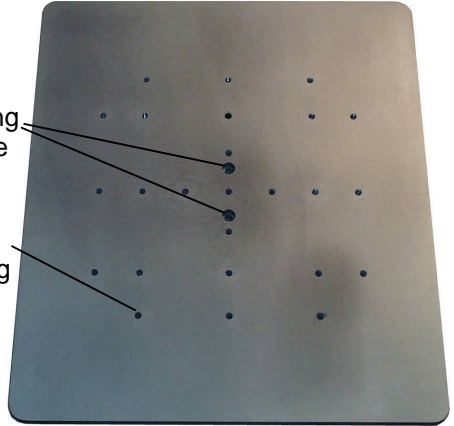

There are 2 versions of the table. The part numbers for each are as follows:

M6 Threads
#10 – 32 Threads

SPK/LFM/0007
SPK/LFM/0008

BOTTOM MOUNTING BOSS

Bottom mounting boss of *LFPlus* showing the 2 M6 tapped holes for securing the accessories to the base

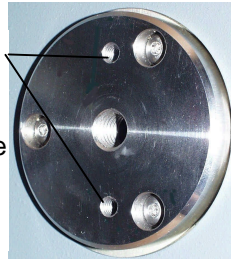

5.0 ACCESSORIES

5.2 T SLOT TABLE



A “T” Slot Table is available to assist with the testing of irregular shaped objects. The “T” slot table has 4 slots on one side and 3 on the other to assist easy anchoring of the part to be tested using customised clamps or by direct fixing to the table. Four “T” slot nuts are supplied the thread in these is M6.

The “T” slot table is attached to the LFPlus by two M6 socket head screws, which are supplied with it. It is mounted on the bottom anchor pin boss.

5.0 ACCESSORIES



“T” Slot Table

The picture above shows the 4 slot side of the table fitted with 4 sliding nuts in the “T” slots for attaching clamps or holding fixtures.



If you want to use the three “T” slot side of the table, remove one of the plastic end caps of the table as shown on the left and slide out the “T” slot nuts.

Turn the table over and fit the nuts in slots you wish to use on the 3 slot side.

Re-fit the plastic end cap.

The table can be used parallel to the front of the *LFPlus* with 4 slots available or at 90° to the front of the machine with 3 slots available, as shown in the picture on the previous page.

If you wish the “T” slot nuts may also be removed without removing the end cap. To do this, twist the nut through 90° longitudinally and lift out of the slot.

5.0 ACCESSORIES

5.3 DRIP TRAY



DRIP TRAY

The optional Drip Tray (SPK/LFM/0010) is designed for catching any liquid that may be spilt when carrying out a test. The drip tray fits around the bottom anchor pin and is clamped in place by the anchor pin, locking nut or the grip threaded adaptor.

Care should be taken not to spill any liquid onto the *LFPlus*, when emptying the drip tray.

6.0 CONTROL PANEL

6.1 CONTROL PANEL DESCRIPTION

The unit has a Liquid Crystal Display (LCD) to show set-up information, load and extension values etc. and a key pad to input information for operating the machine when under control of the console. The machine is set up by answering simple questions and entering information when requested. The operating status of the machine is shown and described on the display.

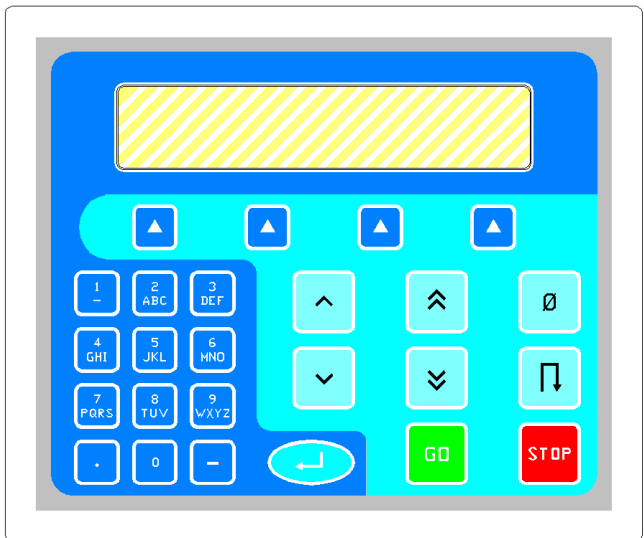

The control Panel

6.2 KEYPAD OPERATION AND DESCRIPTION

The keypad has 25 keys arranged into 4 groups.

6.0 CONTROL PANEL

The **first group** contains 8 keys in the bottom right hand corner of the keypad

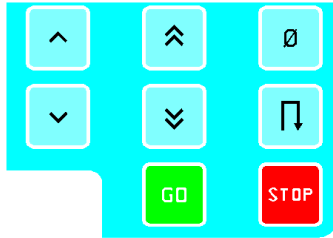

The First Group of Keys





GO The GO button is used to start a test from the machine console and is operable from the “Pre-Test” display.

STOP The STOP key is used to stop a test that is being performed from the machine console, i.e. if the machine does not stop automatically or the user requires to abort the test. The STOP key is not operable when the machine is performing a test under the control of an external computer.

This is not an Emergency Stop Button. The Emergency Stop Button (Mushroom) is located on the left of machine base and can be used to stop the machine in an emergency situation.

JOG These two keys allow the crosshead to be moved slowly
Up \wedge into position when loading and removing samples.
Down \vee They are available when a test is not being performed
and only operate whilst pressed. The crosshead will run
at a user pre-set jog speed (a *set-up* option).

6.0 CONTROL PANEL

- FAST Up**  These two keys allow the crosshead to be moved at maximum speed and therefore it is essential to ensure there are no obstructions. These keys should only be used for moving large distances and not for final adjustment when the grips are close together. They are available when a test is not being performed and only operate whilst pressed.
- Down**  These two keys allow the crosshead to be moved at maximum speed and therefore it is essential to ensure there are no obstructions. These keys should only be used for moving large distances and not for final adjustment when the grips are close together. They are available when a test is not being performed and only operate whilst pressed.
- ZERO**  Pressing this key sets the load and extension values to zero. This is normally carried out at the start of a test but can be used at any time when not performing a test. If Auto Zero was selected in the set-up routine the system will automatically zero when GO is pressed.
- RETURN**  Pressing this key returns the crosshead to the position where the zero button was last pressed. The crosshead will move at maximum speed. The return button is available when a test is not being performed.

The second group contains 4 keys directly below the display. These "Soft Keys" are used to select various options that are identified by the text displayed on the lower lines of the display as described later.



The Second Group of Keys

6.0 CONTROL PANEL

The **third group** contains 12 keys on the left hand side of the keypad. These keys are used to enter text or numbers and are labelled 1 to 9, 0, decimal point and negative sign. Most keys also double up as alphabetical entry keys similar to the style used on mobile phones.

The Third Group of Keys



The **fourth “group”** is one key in the bottom centre of the keypad. This key is the **ENTER** key which is used to accept any entered text, value or unit. It is also used to accept the entries on a completed display and to show the **PREVIOUS** display. The **ENTER** key is not available when a test is being performed or when input from another key is required.

The Fourth “Group” of Keys



6.3 THE DISPLAY

The display, which has 4 lines of 40 characters, is used to show or request information. The information displayed depends upon the status of the machine but generally, the top line displays a title or help information for each display. The lower lines are split into 4 blocks, one block above each Soft Key, to indicate the function of that key.

6.4 “SWITCH-ON” DISPLAY

When first switched on the display will be blank while the system performs some routine checks.

6.0 CONTROL PANEL

After a few seconds the display will show information about the machine and the version of the embedded software installed. Similar to the one shown below.

```
LLOYD INSTRUMENTS LTD
LFPLUS MATERIALS TESTING MACHINE
VERSION 3.0 ISSUE 44
LOAD CELL 001234 N
```

This information is displayed for three seconds after which the test selection screen is displayed.

The next display shows that a test called CYCLE_TEST has been defined. The number in brackets shows the number of sample results currently stored with this test.

```
SELECT THE REQUIRED TEST
CYCLE_TEST (150 SAMPLES)

TEST      <          >      EDIT
```

A total of 600 sample results can be stored across all test set-ups. If the total number of samples currently stored with all the test set-ups exceeds 500 then the third line will display a warning message.

```
SELECT THE REQUIRED TEST
CYCLE_TEST (501 SAMPLES)
WARNING: ONLY SPACE FOR 99 MORE SAMPLES
TEST      <          >      EDIT
```

As the left and right arrow (< >) Soft Keys are pressed, the names of the previously defined tests will be shown.

6.0 CONTROL PANEL

When the first test is displayed, the left arrow will be hidden as shown below.

SELECT THE REQUIRED TEST		
LIMIT_TEST (150 SAMPLES)		
TEST	>	EDIT

When the last test is displayed, and less than 10 set-ups have been defined the display below will be shown.

SELECT THE REQUIRED TEST	
NEW TEST	
<	CREATE

To define a test, refer to Section **9.0 SETTING UP A NEW TEST**, noting that the supervisor may add a password to prevent the operator from entering the EDIT or CREATE modes.

7.0 OPERATIONAL PRECAUTIONS

7.1 SAFETY

LLOYD INSTRUMENTS testing machines are inherently safe if used properly. Operators must be made aware that:-

- 1 High physical forces are involved.
- 2 Samples under test may shatter.
- 3 Electrical power supplies are involved.
- 4 The following must **ALWAYS** be brought to the attention of any operator before they are allowed to use the machine. Hands, fingers and other parts of the body must at all times be kept well away from the moving crosshead. Operators should be particularly careful when moving the crosshead to insert test samples, to ensure that no part of the hand could be accidentally compressed as the crosshead and grips are jogged into position.
- 5 **NEVER** drive the machine from a computer when anyone else is working on or near the machine.
- 6 If there is any danger that liquids may be spilt during tests, operators must use a drip tray (which is available from LLOYD INSTRUMENTS) to guard against the possibility of any spillage entering the machine and giving rise to electrical or other hazards.
- 7 Take extra care when operating in compression mode where specimens may burst, shatter or fly out from between the platens. Operators should STAND CLEAR during testing. Splinter shields are available in various options to suit specific requirements.
- 8 All operators must receive adequate training in basic operation before being allowed to use the machine. Additional copies of this manual are available from LLOYD INSTRUMENTS LIMITED

7.0 OPERATIONAL PRECAUTIONS

- 9 Operators must ensure that the **Emergency Stop Button** is never obstructed.
- 10 Operators must ensure that other personnel working in or near the area are made aware that testing is taking place and that they should not approach the machine while it is in use.
- 11 Operators must ensure that the machine is regularly serviced and calibrated by LLOYD INSTRUMENTS, or one of their accredited service dealers.
- 12 To maintain EMC compatibility, the machine should only be used as prescribed in this manual. Connecting cables, plugs and sockets should be inspected regularly. Cables damaged or worn in any way should not be used. Accessories and accessory connecting leads, if suspect, should be replaced only with a LLOYD INSTRUMENTS approved replacement. Failure to observe this may cause your machine to infringe the EMC legal requirements.
- 13 Never attempt any form of machine maintenance without disconnecting the mains electrical supply.
- 14 Never attempt to test any samples with a type of grip or other accessory, which is not designed for that particular test. Never use grips or the machine for tests in excess of the stated load limits. A comprehensive range of alternative grips, together with an applications advisory service, is available from LLOYD INSTRUMENTS and their accredited dealers.

7.0 OPERATIONAL PRECAUTIONS

7.2 EMERGENCY STOP

If for any reason the machine needs to be stopped without delay, an emergency stop mushroom switch is provided. Pressing this switch stops the LF *Plus* immediately. It can be released by turning a quarter of a turn clockwise. The machine will then go to the initialise / start up sequence if the ON/OFF switch is already ON.



7.3 SPLINTER SHIELDS

Transparent splinter shields are available as an option to enclose the test sample if there is any danger of samples shattering as a result of the test. These shields can be fitted with an electronic interlock so that the test cannot be started until the hinged shield is closed. While not mandatory for many applications and countries, LLOYD INSTRUMENTS strongly recommend that users consider fitting this optional item.

If a shield fitted with electronic interlock is used, the following screen will appear if the door is opened during a test.

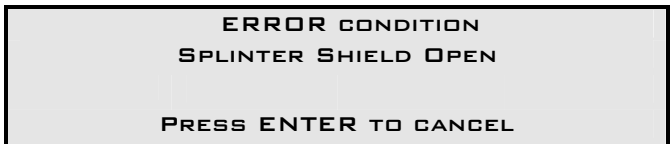

The test in progress will be aborted and the next test or a new test will have to be started.

7.0 OPERATIONAL PRECAUTIONS

7.4 LOWER ANCHOR PIN ADJUSTMENT

The Lower Anchor Pin has two locking collars, one to lock it in position in the lower (fixed) crosshead and the other to screw upwards to lock the bottom grip / fixture firmly in position.

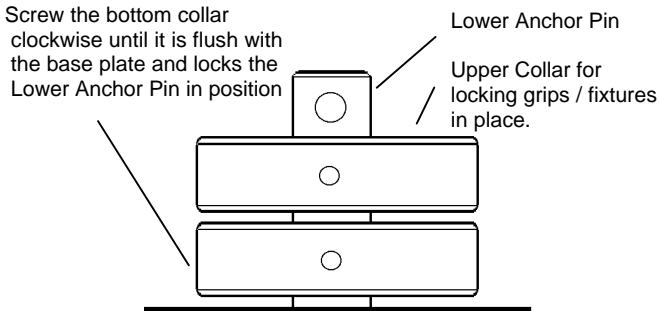

Lower Anchor pin Locking Collars

When the grips or test fixtures have been fitted to the loadcell and bottom anchor pin, carefully align the top and bottom grips or test fixtures. Turn the bottom collar clockwise until it is locked against the lower crosshead in the position required. This is particularly important when carrying out compression tests.

Extreme care must be taken when manoeuvring the crosshead, particularly when low force load cells are being used as they can easily be damaged even at moderate speeds. As an additional precaution during compression testing the lower (hardware) limit stop should be set so that the compression plates cannot come together either during or after a test.

7.0 OPERATIONAL PRECAUTIONS

7.5 LIMIT STOPS

The *LFPlus* machines are fitted with two mechanically activated limit stops. These can be used as extra protection to stop load cells, grips or fixtures coming into contact. The upper one can be used to back up the software limit. Activating a limit stop will result in the machine stopping.

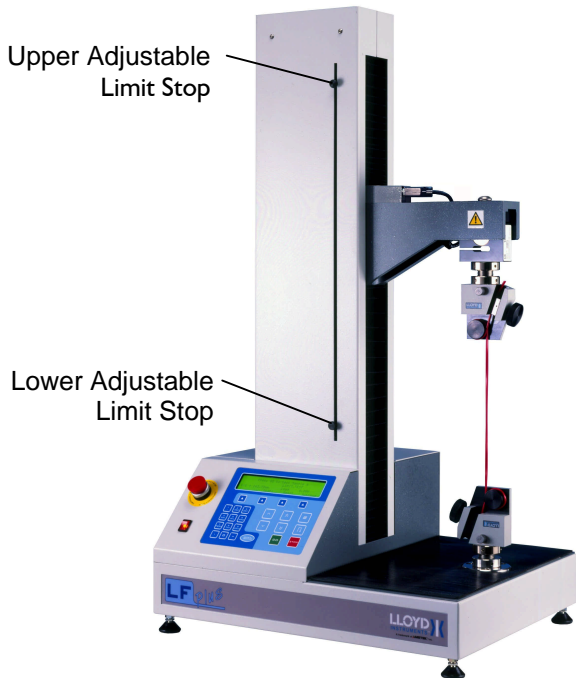

To adjust the lower limit stop, first loosen the lower limit stop screw and move the stop to the bottom of its travel in the slot. Drive the moving crosshead to the lowest position that it may go to safely, without damaging any fitted grips or fixtures. When this position has been reached, drive the crosshead **up** by 3mm (0.125 inch). Move the lower adjustable limit stop up until it stops against the crosshead actuator within the column. Tighten the screw in this position. Ensure the screws are free to move vertically to actuate the switches.

7.0 OPERATIONAL PRECAUTIONS

To adjust the **top** limit stop, loosen the upper limit stop screw and move the screw to the top of its travel and tighten the screw temporarily in this position. Drive the moving crosshead to the highest position it may go to safely, without damaging any fitted grips or fixtures. When this position has been reached, drive the crosshead **down** by 3mm (0.125 inch). Loosen the upper limit stop screw and move the screw down to the limit stop cross head actuator and tighten the screw in this position. Once again, ensure the screws are free to move vertically to actuate the switches.

If during a test or when manoeuvring the crosshead, a limit stop switch is activated, a display as shown below or similar will be seen.

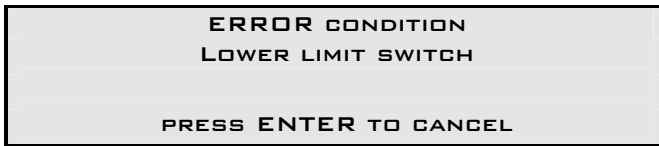

When **ENTER** has been pressed and this display has been cleared the machine will only allow the operator to drive the crosshead away from the limit stop.

8.0 PERFORMING A TEST

8.1 PERFORMING A TEST

The *LFPlus* machines can be used to perform tests in two modes, as a stand-alone machine or under computer control with **NEXYGEN™** software.

If the machine is to be used with a computer and **NEXYGEN™** MT or **NEXYGEN™** FM software, then the **NEXYGEN™** Software User Manual supplied with the software, should be read in conjunction with this manual. The machine should be connected to the computer with the RS232 lead supplied. When the machine is on and ready, the computer connected with the lead supplied and **NEXYGEN™** running, connection between the machine and computer is automatic.

If the *LFPlus* machine is being used in “stand alone” mode, proceed as follows. The following information will also be needed for “setting up” the machine with grips, samples etc.

8.2 TEST PARAMETERS

SAMPLE PREPARATION The Jog Keys are used to prepare for a test. The accessories being used will be dependent on the type of test being conducted.

LOAD CELLS The correct load cell should be fitted in the machine for the application being undertaken. Great care should be taken with these as they are precision measurement devices and can be damaged if used incorrectly. Please make sure that you have read Section 4.3 carefully before proceeding further.

8.0 PERFORMING A TEST

GRIPS/ ADAPTORS

It is important that grips are fitted along the central straining axis of the machine and that no side loads are applied to the load cell as this will affect the accuracy of the load readings. The grips should be connected to the load cell and the bottom anchor pin or fixture using only the pins and parts provided. Care should be taken not to exceed the load rating of the grips. It is important to ensure that the grips used are suitable for the material under test. Any slippage of the material in the grips will affect both load and extension readings.

EXTEN- SOMETERS

It is important to understand that the extension that the crosshead moves does not give a true reading of the strain in the samples. If we consider a dumbbell sample for instance, the strain will be different at different positions along the sample and no account is being taken of the take up of slack or bedding in of the grips. For accurate strain readings we would strongly recommend the use of a LLOYD INSTRUMENTS extensometer, which is suited for the material under test.

8.3 SELECTING A TEST

The user selects the required existing pre-programmed test by pressing the left and right arrow Soft Keys until the required test is shown on the display, then pressing the **Test** Soft Key.

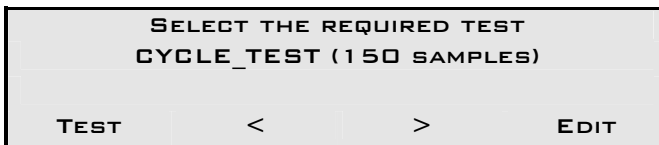

Depending on how the test has been set up one or more of the following screens will be displayed. Refer to Section **9.0 SETTING UP A NEW TEST** for details on setting these options.

8.0 PERFORMING A TEST

If an external extensometer has been selected for use then the following screen will be displayed if the required extensometer is not fitted.

REQUIRED EXTENSOMETER NOT FITTED			
LASERSCAN			
ABORT			

If the external extensometer is fitted but has a selectable range the following screen will be displayed.

CHECK EXTENSOMETER RANGE			
500.00			
MM			
ACCEPT		ABORT	

The external extensometer range must be set to the range displayed on this screen for the measurement of extension to be correct.

If a plotter output has been selected and a plotter interface box connected then the following screen will be displayed.

CHECK PLOTTER CALIBRATION			
MAXIMUM LOAD	100.0N		
MAXIMUM EXTENSION	100.0MM		
ACCEPT		ABORT	CALIBRATE

Pressing the Calibrate Soft Key allows the user to the following screen

OUTPUT A PLOTTER LIMIT			
		OUTPUT	OUTPUT
		100.0	100.0
ACCEPT	ABORT	N	MM

8.0 PERFORMING A TEST

If the batch questions option is turned on, then the following screen will be displayed. A “batch” being a series of tests all carried out with the same settings. The “batch questions” are 3 two word questions which can be set-up at the beginning of a new “batch”

PRESS A KEY TO CHANGE A PARAMETER			
OPERATOR	BATCH		
NAME	NUMBER		
			SUSPEND

The information can only be entered when a new batch is started i.e. when sample number 1 is to be tested. The operator can answer the questions by pressing the Soft Key below each question.

Pressing the **Enter** key will confirm all the answers to the batch questions and show the pre-test display.

If the operator is continuing with a previously suspended batch, then the batch questions, and their answers, will be displayed in a “view only” mode.

OPERATOR	DAVE
BATCH NUMBER	B21_G
CONTINUE	SUSPEND

Here the operator will be given the option to **CONTINUE** with the previously suspended batch or to **SUSPEND** the batch again by pressing the appropriate Soft Keys.

PRESS GO TO TEST SAMPLE 1			
6.00MM X 3.00MM		MOULD_32	
EXT -	10.00MM	LOAD -	276N
SAMPLE	STATS	RESET	SUSPEND

On the top line of the Pre-test display help information is shown. On the second line, the right hand side shows the test setup name.

On the third line, Extension and Load are displayed.

8.0 PERFORMING A TEST

The extension symbols - or $\bar{\quad}$ indicate the direction of the extension from the “soft zero” position. “Soft zero” being the position at which the \bar{A} key was last pressed.

The load symbols - or $\bar{\quad}$ indicate a Tensile Force or Compressive Force, respectively.

If the sample questions option is turned on, then next to the test name the sample width and thickness, diameter or area information will be shown. The **SAMPLE** Soft Key will also be displayed. Refer to Section **9.0 SETTING UP A NEW TEST** for details on setting these options.

Pressing the **SUSPEND** Soft Key returns to the test selection display but saves the statistics and last sample number ready to continue the batch later.

Pressing the **RESET** Soft Key resets all the batch results, sets sample number to 1 and shows the display that would be selected when first selecting the test, i.e. batch or pre-test. This is only done after confirmation by the operator.

Pressing the **STATS** Soft Key will show the statistics for the samples tested so far and allow them to be printed.

Pressing the **SAMPLE** Soft Key will display the sample question screen shown below.

PRESS A KEY TO CHANGE A PARAMETER			
GAUGE	WIDTH	THICKNESS	SAMPLE
25.00	6.00	3.00	NUMBER
MM	MM	MM	

This display allows the operator to enter the sample dimensions and a single description. The text for the 3 sample fields depends upon the test mode and sample type. The first field will say **GAUGE** for Tension or **HEIGHT** for Compression. The second field will say **WIDTH** for Rectangular, **DIAMETER** for Circular or **AREA** for Area.

8.0 PERFORMING A TEST

The third field will only be displayed for Rectangular samples and will say **THICKNESS**. The fourth field will display the sample question defined in the test setup. The Soft Keys allow the sample dimensions to be altered and the sample question to be answered.

8.4 STARTING A TEST

When all the test parameters have been set as per **8.3 SELECTING A TEST** above, press **GO** to start the test and display one of the screens below.

For a Limit Test:

PERFORMING TEST	MOULDED_RUBBER
MOVING TO LIMIT POINT	
EXT - 10.00MM	LOAD - 276N

or for a Cycling Test

PERFORMING TEST	MOULDED_RUBBER
MOVING TO LIMIT POINT. CYCLE 3	
EXT - 10.00MM	LOAD - 278N

The *LFPlus* is supplied with three pre-defined test setups and one for new test setups, these are:-

LIMIT_TEST, CYCLE_TEST, BREAK_TEST, NEW_TEST

These are described in section **9.1 PRE-DEFINED TEST SETUPS**

8.0 PERFORMING A TEST

8.5 STOPPING A TEST

When the test ends, either automatically or if the user presses the **STOP** key, the post test screen will be displayed

SAMPLE 1 PASSED			
PK LOAD	367N	BRK LOAD	237N
PK EXT	126.50MM	BRK EXT	157.80MM
PRINT	STATS	ACCEPT	CANCEL

This screen will display different amounts of information depending on how the test has been set up. Refer to Section **9.0 SETTING UP A NEW TEST** for details on setting these options.

8.6 PRINTING TEST RESULTS

Pressing the **PRINT** Soft Key will either print just the single result or, if **ALL** was selected for the **SAMPLE PRINTOUT** option in the test setup, together with the machine setup details, i.e. test speed etc.

8.7 CANCELLING OR ACCEPTING THE RESULTS

Pressing the **CANCEL** Soft Key will cancel the result (abort) and remove the result from the batch.

Pressing the **ACCEPT** Soft Key or the **ENTER** key will accept the results and add them to the batch.

8.0 PERFORMING A TEST

8.8 VIEWING THE STATISTICS

Pressing the **STATS** Soft Key will accept the result and show the statistics screen as below:-

	PK LOAD	PK EXT	
MEAN	367N	126.57M	
DEV'N	5N	24.18MM	
PRINT			>

Pressing **>** Soft Key will show the second statistics screen:-

	BRK LOAD	BRK EXT	
MEAN	137N	155.03M	
DEV'N	12N	54.13MM	
PRINT			<

Pressing the **PRINT** Soft Key from the statistics screen will show the 'print options' screen shown below:-

PRINT OPTIONS FOR CYCLE_TEST		
STATS	BRIEF	FULL
ONLY	REPORT	REPORT

Pressing the **STATS ONLY** Soft Key will give a table of statistics only, without the test value.

Pressing the **BRIEF REPORT** Soft Key will give a table of test values and statistics.

Pressing the **FULL REPORT** Soft Key will give a table of test values, statistics and test setup information.

8.0 PERFORMING A TEST

8.9 ERROR CONDITIONS

If an error condition exists the cause of the error will be shown on the display. This error must be cleared before you can proceed with the test. See **Section 10.1** for details of error messages

9.0 SETTING UP A NEW TEST

9.1 PRE-DEFINED TEST SETUPS

The *LFPlus* is supplied with three pre-defined test setups and one for new test setups, these are:-

LIMIT_TEST A test which is carried out to a limit. The limits are defined in mm or inches, % elongation (after setting gauge length), Newtons, Kg force, lbs force, Mega Pascal's Mpa (have entered the sample dimensions), Kg force per mm² and lb force per inch²

CYCLE_TEST A cycle is from home to a limit (as set out above) and back to home. If when the test starts the crosshead is not at the home position, it will move to the home position first before going to the limit position. The machine can be set to perform up to 10000 cycles per test. If necessary this 10000 limit can be raised by your agent or dealer.

BREAK_TEST A Break Test will either, stop at a limit as described above or when a break is detected. There are 2 types of break detector. A % break detector which detects when the load has dropped to 50% of the maximum peak load detected and sharp break detector. The sharp break detector operates when there has been a sharp change in load or direction between one load reading and the next.

NEW_TEST Is a user defined test rather than one of the default settings which are detailed on the next page.

9.0 SETTING UP A NEW TEST

The Default test setups are as follows:-

Test name >	LIMIT_TEST	CYCLE_TEST	BREAK_TEST	NEW_TEST
Test Type	Settings			
Test mode	Tension	Tension	Tension	Tension
Test type	Limit	Cycling	Limit	Limit
Limit position	10.0mm	10.0mm	N	10.0mm
Home position		0.0mm		
No. of cycles		10		
Preload	0.0N	0.0N	0.0N	0.0N
Speed	250mm/min	250mm/min	25mm/min	250mm/min
Hold	0 seconds			0 seconds
Machine Stiffness Compensation	Disabled	Disabled	Disabled	Disabled
Test Options				
Sharp Break detector	off	off	on	Off
% Break Detector	off	off	off	Off
Return to zero	manual	Manual	manual	Manual
Zero readings	manual	Manual	manual	Manual
Sample printout	All	All	All	All
Extensometer Used	Internal	Internal	Internal	Internal
Test Results				
Peak Load	N	N	N	N
Extens'n at peak load	mm	mm	mm	Mm
Break load	N	N	N	N
Extension at Br'k load	mm	mm	mm	Mm
Pass/fail Checks	off	off	off	Off
Define Sample				
Sample type	Rectangular	Rectangular	Rectangular	Rectangular
Gauge	25.00mm	25.00mm	25.00mm	25.00mm
Width	6.00mm	6.00mm	6.00mm	6.00mm
Thickness	3.00mm	3.00mm	3.00mm	3.00mm
1st Batch ? line 1	OPERATOR	OPERATOR	OPERATOR	OPERATOR
1st Batch ? line 2	NAME	NAME	NAME	NAME
2nd Batch ? line 1	BATCH	BATCH	BATCH	BATCH
2nd Batch ? line 2	NUMBER	NUMBER	NUMBER	NUMBER
3rd Batch ? line 1				
3rd Batch ? line 2				
Sample ? line 1	SAMPLE	SAMPLE	SAMPLE	SAMPLE
Sample ? line 2	ID	ID	ID	ID
Batch questions	off	off	off	Off
Sample questions	off	off	off	Off

9.0 SETTING UP A NEW TEST

9.2 DEFAULT GLOBAL SETTINGS

The Default Global Settings are:-

Field	Setting
Password	<None>
Safety load	50N
Slow jog speed	10mm/min
Data format	Printer
Grip protection Tension	110% of frame rating
Grip protection Compression	110% of frame rating
Language	English

To enter a New Test Setup or Edit a pre-defined setup, proceed as follows.

9.3 EDITING A PRE-DEFINED TEST SETUP

To edit a previously defined test setup, select the required test, using the left and right arrow keys, until the required test is displayed then press the **Edit** Soft Key.

This is the Select/Edit Display.

SELECT THE REQUIRED TEST			
CYCLE_TEST (150 SAMPLES)			
TEST	<	>	EDIT

9.4 PASSWORD ACCESS

If the machine has been given a password, the password entry display will be shown.

ENTER THE PASSWORD TO EDIT THIS TEST	
BKSP	CLEAR ALL

Type the password then press the **ENTER** key .

9.0 SETTING UP A NEW TEST

If the password is not correct, the test Select/Edit Display will be redisplayed.

If the password is correct, the main setup display is shown.

This is the Main Setup Display

PRESS A KEY TO SELECT AN OPTION			
CYCLE_TEST			
RENAME	GLOBAL	DELETE	SETUP

Pressing the **ENTER** key will return to the Select/Edit display.

9.5 RENAMING A TEST

Pressing the **RENAME** Soft Key will allow the setup name to be changed. If a new test is created, the name will be automatically set to new_test.

9.6 DELETING A TEST

Pressing the **DELETE** Soft Key will allow the selected test setup and all associated sample results to be deleted. The following screen will appear.

DELETE TEST CYCLE_TEST	
ARE YOU SURE?	
YES	NO

9.0 SETTING UP A NEW TEST

9.7 GLOBAL SETTINGS

Pressing the **GLOBAL** Soft key will allow the Password and Jog speed etc. to be changed. (see **Main Setup Display** page 47.)

PRESS A KEY TO CHANGE A PARAMETER			
CHANGE	SAFETY	SLOW JOG	
PASSWORD	50.0	100	
CHRIS	N	MM/MIN	>

PRESS A KEY TO CHANGE A PARAMETER			
DATA	SET	CURRENT	
FORMAT	GRIP	LANGUAGE	
PRINTER	PROTECT'N	ENGLISH	>

PRESS A KEY TO CHANGE A PARAMETER		
SET		
MACHINE		
STIFFNESS		<

9.8 SETTING A PASSWORD

Pressing the **CHANGE PASSWORD** Soft Key brings up the following display:

CHANGE OR CREATE THE PASSWORD	
CHRIS	
BKSP	CLEAR ALL

Pressing **BKSP** Soft Key deletes one character at a time starting from the right hand end of the password.

Pressing the **CLEAR ALL** Soft Key deletes all the characters.

9.0 SETTING UP A NEW TEST

The Alphanumeric keys add new characters to the password the **ENTER** key accepts the password as displayed.

If the password displayed is blank then there will be no password protection.

The password limits access to the edit test setup menus. If a password has been set this password will be required before any parameter of any test setup can be edited. The selection and running of previously defined test setups is not affected.

9.9 SAFETY LOAD LIMIT

The **SAFETY** limit is intended as an extra protection against accidental injury. It applies when the **JOG** keys are pressed or during return when the crosshead is moving down. Entering a high value for this option will reduce the level of safety provided and should only be done to overcome nuisance errors caused by high friction in some accessories.

9.10 SLOW JOG SPEED

The **SLOW JOG** setting allows the user to specify the speed that the crosshead will move when the slow **JOG** keys are pressed.

9.11 SETTING FOR PRINTER

The **DATA FORMAT** Soft Key toggles between **PRINTER** and **ASCII** (ASCII for when a DATALOGGER is to be used).

9.0 SETTING UP A NEW TEST

9.12 GRIP PROTECTION SETTINGS

The **GRIP PROTECTION** setting is an additional load limit, which can be used to protect grips or accessories that are being used. The test will be stopped if the value of load exceeds the **GRIP PROTECTION** setting during a test.

9.13 CURRENT LANGUAGE

Pressing the **CURRENT LANGUAGE** soft key allows the user to select the language to be used from the list of languages supported by the machine. The chosen language will be used for all information presented to the user, including information output to a printer.

9.14 MACHINE STIFFNESS

Pressing the **SET MACHINE STIFFNESS** soft key allows the user to perform a machine stiffness compensation.

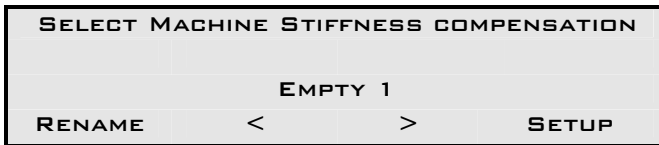

Use the **<** or **>** soft keys to select the machine stiffness compensation slot to use for the compensation. There are 10 machine stiffness compensation slots.

Use the **RENAME** soft key to change the name of the current machine stiffness slot.

Use the **SETUP** soft key to setup the machine stiffness compensation range and perform a machine stiffness compensation.

9.0 SETTING UP A NEW TEST

PRESS A KEY TO CHANGE A PARAMETER			
TEST	SET	SET	
MODE	PRELOAD	LIMIT	
COMPRES'N	VALUE	VALUE	PERFORM

Use the **TEST MODE** soft key to select Tension or Compression Machine Stiffness compensation.

Use the **SET PRELOAD VALUE** soft key to set the start value for the machine stiffness compensation.

It is recommended that the minimum value for the machine stiffness compensation start value (Preload) is 1% of load cell value.

Use the **SET LIMIT VALUE** soft key to set the machine stiffness compensation end value.

Use the **PERFORM** soft key to perform a machine stiffness compensation.

9.15 TEST SETUP DISPLAY

Pressing the **SETUP** Soft Key from the Main Setup Display will show the test setup display.

This is the Test Setup Display

PRESS A KEY TO SELECT AN OPTION			
MOULDED_RUBBER			
TEST	TEST	TEST	DEFINE
TYPE	OPTIONS	RESULTS	SAMPLE

9.0 SETTING UP A NEW TEST

9.16

TEST TYPE

Pressing the **TEST TYPE** Soft Key will allow the test type to be defined.

PRESS A KEY TO CHANGE A PARAMETER			
TEST	TEST	SET	
MODE	TYPE	LIMIT	
TENSION	LIMIT	VALUES	>

Pressing the **>** Soft Key will toggle between the display above and the next display.

PRESS A KEY TO CHANGE A PARAMETER			
SPEED	SET	MACHINE	
150	PRELOAD	STIFFNESS	
MM/MIN	VALUES	ENABLED	<

The **TEST MODE** Soft Key toggles between **TENSION** and **COMPRESSION**.

The **TEST TYPE** Soft Key toggles between **LIMIT** and **CYCLING**. In cycling mode the **SET LIMIT VALUES** Soft Key changes to **SET CYCLING VALUES**.

Pressing the **SET LIMIT VALUES** Soft Key will allow the values to be set.

PRESS A KEY TO CHANGE A PARAMETER	
LIMIT	HOLD
10.00	0
MM	SECONDS

The limit type, value and unit may be set or changed by pressing the **LIMIT** Soft Key. The required parameters may then be entered.

9.0 SETTING UP A NEW TEST

If either a **HOLD** value is set or if the units of **SPEED** are in load rate units sample stiffness information will be displayed.

PRESS A KEY TO CHANGE A PARAMETER			
LIMIT	HOLD	SAMPLE	INITIAL
10.0	30	STIFFNESS	100000.0
MM	SECONDS	AUTO	N/MM

SAMPLE STIFFNESS can be set to **AUTO** (see above) or **MANUAL** (see screen below). Sample stiffness is used when a test is being carried out under load rate control, i.e. when driving at a rate of Newtons per minute or lbs per inch. The machine speed will have to vary depending on the stiffness of the sample.

MANUAL Sample stiffness uses the value entered throughout the test. **AUTO** sample stiffness starts from an **INITIAL** value and throughout the test re-calculates this value.

PRESS A KEY TO CHANGE A PARAMETER			
LIMIT	HOLD	SAMPLE	STIFFNESS
10.0	30	STIFFNESS	100000.0
MM	SECONDS	MANUAL	N/MM

Pressing the **SET CYCLING VALUES** Soft Key will allow the values to be set.

PRESS A KEY TO CHANGE A PARAMETER		
LIMIT	HOME	NUMBER
20.0	10.0	OF CYCLES
MM	MM	2

9.0 SETTING UP A NEW TEST

The **HOME** position is the start of the Cycle Test position and wherever the machine is resting after loading it will drive first to the **HOME** position. After reaching the home position it will drive to the **LIMIT** position and back to the **HOME** position to complete the first cycle. The machine's response to inputs as shown above is illustrated in the **NEXYGEN™** graph shown below

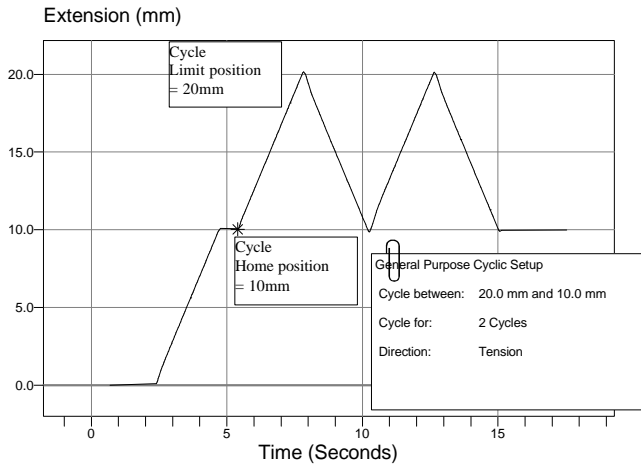

Pressing the **SET PRELOAD** Soft Key will allow the values to be set. It is recommended that the minimum value entered is no less than 1% of the Loadcell value fitted.

PRESS A KEY TO CHANGE A PARAMETER	
SPEED	LIMIT
10	0.00
MM/MIN	N

9.0 SETTING UP A NEW TEST

9.17 SELECTING MACHINE STIFFNESS COMPENSATION

PRESS A KEY TO CHANGE A PARAMETER			
SPEED	SET	MACHINE	
150	PRELOAD	STIFFNESS	
MM/MIN	VALUES	DISABLED	<

Pressing the **MACHINE STIFFNESS** soft key enables the user to select the machine stiffness compensation to use in the current selected test setup

PRESS A KEY TO CHANGE A PARAMETER			
EMPTY 1			
ENABLED	<	>	

9.18 TEST OPTIONS

Pressing the **TEST OPTIONS** Soft Key from the test setup display will allow the test options to be set.

PRESS A KEY TO CHANGE A PARAMETER			
BREAK			
DETECTOR	RETURN	ZERO	
SHARP	AUTO	MANUAL	>

Pressing the **>** key will toggle between the above display and the next display.

PRESS A KEY TO CHANGE A PARAMETER			
SAMPLE	EXTENSOR		
PRINTOUT	USED		
ALL	LFPLUS		>

If the **>** key is pressed the following screen will appear.

9.0 SETTING UP A NEW TEST

PRESS A KEY TO CHANGE A PARAMETER	
PLOTTER	
OUTPUT	
DISABLED	<

By pressing the **BREAK DETECTOR** Soft Key the following display is shown

Sharp Break Detector

PRESS A KEY TO CHANGE A PARAMETER		
SHARP	PERCENT	START
BREAK	BREAK	50
ON	OFF	N

There are two break detectors, a sharp break detector and a percentage of peak load break detector. The sharp break detector operates when there has been a sharp change in load or direction between one load reading and the next. Either break detector is turned On or Off by pressing the appropriate Soft Key. Only one break detector can be turned On at a time. When a break detector is turned On, other options are displayed. Both break detectors have a **START** option and the Percentage break detector also has a **PERCENTAGE BREAK** option.

Percentage of Peak Load Break detector

PRESS A KEY TO CHANGE A PARAMETER			
SHARP	PERCENT	START	BREAK
BREAK	BREAK	50	POINT
OFF	ON	N	50 %

The **START** option sets the threshold above which the peak load must rise before the break detector will start operation. The **PERCENT BREAK** option sets the percentage of peak load below which the measured load must fall to constitute a break.

The **RETURN** and **ZERO** options toggle between **MANUAL** and **AUTO**

9.0 SETTING UP A NEW TEST

Pressing the **EXTENSOMETER USED** Soft Key will allow the selection of any extensometer currently fitted from the following screen.

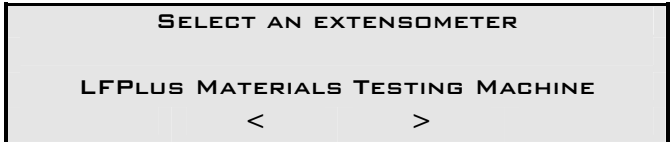

The left and right arrow (< >) Soft Keys will scroll through the list of currently connected extensometers, (theoretically a maximum of 4 with the internal crosshead position always being listed as one of these). The internal crosshead position extensometer is displayed as the **LFPLUS** materials testing machine, i.e., **LFPLUS**. Press the **ENTER** key to select the displayed extensometer.

If the selected extensometer has a selectable range, then an additional option will be displayed in the Test Options screen.

PRESS A KEY TO CHANGE A PARAMETER		
SAMPLE	EXTENSOMETER	RANGE
PRINTOUT	USED	800.00
ALL	EXH750	MM

<

The extensometer range will default to the maximum range of the extensometer but can be changed by pressing the **RANGE** Soft Key.

9.0 SETTING UP A NEW TEST

Pressing the **SAMPLE PRINTOUT** Soft Key, toggles between “**RESULT**” and “**ALL**”. “**RESULT**” will print the 4 results and “**ALL**” will print the 4 results and the machine parameters.

Pressing the **PLOTTER OUTPUT** Soft Key, toggles between “**DISABLED**” and “**ENABLED**”. In the “**ENABLED**” position, the following screen will be displayed where the plotting parameters can be set.

PRESS A KEY TO CHANGE A PARAMETER			
PLOTTER	LOAD	EXT	
OUTPUT	100.0	100	
ENABLED	N	MM	<

9.19 TEST RESULTS

Pressing the **TEST RESULTS** Soft Key from the Test Setup Display will allow the test results units and pass/fail limits to be set.

PRESS A KEY TO CHANGE A PARAMETER	
TEST	PASS/FAIL
RESULT	CHECKS
UNITS	OFF

Pressing the **TESTS RESULT UNITS** Soft Key allows the units to be set.

PRESS A KEY TO CHANGE A PARAMETER			
PEAK	PEAK	BREAK	BREAK
LOAD	EXT	LOAD	EXT
N	MM	N	MM

9.20 PASS/FAIL VALUES

If **PASS/FAIL** is set to **ON**, another 2 options are available.

9.0 SETTING UP A NEW TEST

PRESS A KEY TO CHANGE A PARAMETER			
TEST	PASS/FAIL	BREAK	PEAK
RESULT	CHECKS	PASS/FAIL	PASS/FAIL
UNITS	ON	LIMITS	LIMITS

Pressing either the **BREAK PASS/FAIL LIMITS** or **PEAK PASS/FAIL** Soft Keys will allow the values to be set.

Break pass/fail values

PRESS A KEY TO CHANGE A PARAMETER			
MAX LOAD	MIN LOAD	MAX EXT	MIN EXT
5000	100	250.00	100.00
N	N	MM	MM

9.21

DEFINING SAMPLE

Pressing the **DEFINE SAMPLE** Soft Key from the **Test Setup Display** will allow the sample/batch details to be set.

PRESS A KEY TO CHANGE A PARAMETER			
		BATCH	SAMPLE
SAMPLE	PRE-TEST	QUESTIONS	QUESTION
INFO	QUESTIONS	OFF	OFF

The **BATCH QUESTIONS** and **SAMPLE QUESTION** Soft Keys toggle between **ON** and **OFF** to specify which pre-test question displays will be shown.

Pressing the **SAMPLE INFO** Soft Key will allow the sample details to be defined.

PRESS A KEY TO CHANGE A PARAMETER			
SAMPLE	GAUGE	WIDTH	THICKNESS
TYPE	25.00	6.00	3.00
RECT'R	MM	MM	MM

9.0 SETTING UP A NEW TEST

Pressing the **SAMPLE TYPE** Soft Key toggles between **RECT'R / CIRCULAR / AREA**. The titles **GAUGE**, **WIDTH** and **THICKNESS** depend upon the test mode and the sample type. The title **GAUGE** becomes **HEIGHT** for Compression. The title **WIDTH** becomes **DIAMETER** for Circular or **AREA** for Area. The title **THICKNESS** is only displayed for **RECT'R**.

9.22 PRE-TEST QUESTIONS

Pressing the **PRE-TEST QUESTIONS** Soft Key allows the pre-test questions to be defined. The **BATCH** questions come at the beginning of the batch and help define the batch. The **SAMPLE** question comes up before each sample in a batch and helps identify each sample

PRESS A KEY TO CHANGE A PARAMETER			
BATCH 1	BATCH 2	BATCH 3	SAMPLE
OPERATOR	BATCH		SAMPLE
NAME	NUMBER		NUMBER

Up to 3 batch questions and 1 sample question may be defined.

10.0 ERROR CONDITIONS

10.1 ERROR CONDITIONS

On the *LFPlus*, if an error occurs, a message will be displayed on the console describing the error. This message must be cleared by pressing the **ENTER** key before proceeding. Some errors are displayed when the machine is first powered on and indicate faults that were detected during the power up sequence.

If the *LFPlus* machine is being used with a computer and **NEXYGEN™** software, similar messages will be displayed on the computer by **NEXYGEN™**.

The ERROR messages are as follows:

DATA PACKET ERROR

This error indicates that an invalid data packet has been received across the RS232 interface. All data transferred via RS232 is checked for errors and resent if any error occurs, so this message should never be displayed. If it is seen it is indicative of other problems occurring either within the machine or at the PC.

MOTOR DRIVE FAULT

This indicates that the motor drive system has reported an error condition.

UPPER LIMIT SWITCH

The adjustable upper limit switch has been hit. This can be cleared by adjusting the upper limit or driving off it using the jog down keys.

LOWER LIMIT SWITCH

The adjustable lower limit switch has been hit. This can be cleared by adjusting the lower limit, or driving off it using the jog up keys.

NO LOADCELL AVAILABLE

An attempt has been made to drive the machine without a load cell connected. Ensure the load cell is properly connected and try again.

10.0 ERROR CONDITIONS

SPLINTER SHIELD OPEN

The splinter shield fitted to the machine is open. A test cannot be started until the splinter shield is closed.

CELL OVERLOAD

The load applied to the system is in excess of 110% of the load cell rating. Use the jog keys to remove the load.

SAFETY OVERLOAD

The load applied to the load cell is in excess of the safety load limit in the global settings. This limit only applies when the crosshead is moving downwards during return or under control of the jog keys.

FRAME OVERLOAD

The load applied to the system is in excess of 105% of the frame rating. Use the jog keys to remove the load.

GRIP OVERLOAD

The load applied to the system is in excess of the grip protection limit in the global settings. This limit only applies during a test.

PRINT UNAVAILABLE. POWER DOWN AND RETRY

An attempt has been made to print when the RS232 port is in use with a PC running **NEXYGEN™**. After using the machine with **NEXYGEN™**, it is necessary to power down before it is possible to print.

UNEXPECTED RESET CODE XX

UNEXPECTED SOFTWARE RESET CODE XXX

SOFTWARE RESET CODE 106 (XXXXXX)

These messages indicate that an internal error has caused the system to reset unexpectedly. Please make a note of the readings and contact LLOYD INSTRUMENTS Technical Support for help:-

For LLOYD INSTRUMENTS:

Telephone:- + 44 (0) 1489 486 422

or

Email:- techsupport@ametec.co.uk

10.0 ERROR CONDITIONS

SYSTEM HARDWARE ERROR

An error has occurred in the internal electronics of the system.

DRIVE SYSTEM ERROR

The motor control system has not been able to maintain adequate control of the motor and has shut down as a safety precaution. This will usually indicate a fault within the motor drive or extension measurement system.

ACCESSORY CONNECTED/DISCONNECTED

An accessory has been connected or removed while the crosshead is being driven.

LOAD / SPEED / RATING EXCEEDED

The machine has moved outside the load and speed rating of the machine. Ensure the test being performed is within the machine's load and speed rating

EXTENSOMETER RANGE EXCEEDED

The machine has moved outside the range of the extensometer. Ensure the test being performed is within the range of the extensometer.

11.0 CLEANING AND MAINTENANCE

11.1 CLEANING EXTERNAL FINISH AND TRIM

The finish and appearance of your machine can be maintained by regular cleaning with a damp cloth containing a small amount of mild detergent. The machine should be turned OFF and disconnected from the mains supply whilst cleaning is taking place. Strong proprietary cleaners and petroleum based or other solvents should not be used.

CAUTION: Take care to use only a damp cloth. NO moisture must ever be allowed to get into the machine. Wipe the machine dry before connecting to the mains supply and restarting.

11.2 MAINTENANCE

In normal use and conditions, your machine should be serviced and calibrated annually by LLOYD INSTRUMENTS or one of their appointed agents. There are no user serviceable or adjustable parts within the machine, therefore service and calibration should only ever be undertaken by engineers trained for the task.

If the machine is being used in a particularly arduous way or under extreme conditions, your appointed service agent may recommend more frequent calibration/service.

12.0 SPECIFICATION

12.1 TECHNICAL SPECIFICATION LFPLUS

Maximum Force (Tension and Compression)	1000N (224.8lbf)
Overall Force Range Using Interchangeable Load Cells	0.1N - 1000N (0.02 – 224.8lbf)
Force Measuring System	Exceeds the requirements of BSEN ISO 7500 – 1: 1999 Class 0.5 ASTM E4, DIN 1221
Force Measuring Accuracy	Better than 0.5%
Crosshead Speed Range	0.05 - 1270mm/min at full load (0.002 - 50in/ min at full load)
Crosshead Speed Accuracy	± 0.2% at steady state
Maximum Working Between force line and Column	175mm (6.9in)
Crosshead Travel	500mm (20 in)
Internal Extension Resolution	Better than 1 micron
External Extensometer Connection. (Using LLOYD INSTRUMENTS interface plug)	Analogue (0-1V), (0-10V) or strain gauge. Digital encoders (Single or dual differential)
Frame Stiffness Without Load Cell.	Less than 1mm / 1000N (5709 lbf/in)
Supply Voltage	230V a.c. ±10% 50-60Hz Fuse 1A (T) or 115V a.c. ±10% 50-60Hz Fuse 2A (T)
Power Consumption	120 VA max.
Main Frame Dimensions	Height 913mm (35.9in) Depth 400mm (15.7in) Width 500mm (19.7in)
Mass (no Load Cell or Grips fitted)	46kg (102lb)
Temperature (operating) (storage)	5 to 35°C (40°F to 95°F) -20 to 55°C (4°F to 130°F)
Atmospheric	5 to 85% RH (Non- condensing)

12.0 SPECIFICATION

12.2 TECHNICAL SPECIFICATION LFPLUS EXTENDED

Maximum Force (Tension and Compression)	1000N (224.8lbf)
Overall Force Range Using Interchangeable Load Cells	0.1N - 1000N (0.02 – 224.8lbf)
Force Measuring System	Exceeds the requirements of BSEN ISO 7500 – 1: 1999 Class 0.5 ASTM E4, DIN 1221
Force Measuring Accuracy	Better than 0.5%
Crosshead Speed Range	0.05 - 1270mm/min at full load (0.002 - 50in/ min at full load)
Crosshead Speed Accuracy	± 0.2% at steady state
Maximum Working Between force line and Column	175mm (6.9in)
Crosshead Travel	750mm (30 in)
Internal Extension Resolution	Better than 1 micron
External Extensometer Connection. (Using LLOYD INSTRUMENTS interface plug)	Analogue (0-1V), (0-10V) or strain gauge. Digital encoders (Single or dual differential)
Frame Stiffness Without Load Cell.	Less than 1mm / 1000N (5709 lbf/in)
Supply Voltage	230V a.c. ±10% 50-60Hz Fuse 1A (T) or 115V a.c. ±10% 50-60Hz Fuse 2A (T)
Power Consumption	120 VA max.
Main Frame Dimensions	Height 1170mm (46in) Depth 400mm (15.7in) Width 500mm (19.7in)
Mass (no Load Cell or Grips fitted)	50kg (111lb)
Temperature (operating) (storage)	5 to 35°C (40°F to 95°F) -20 to 55°C (4°F to 130°F)
Atmospheric	5 to 85% RH (Non- condensing)

12.0 SPECIFICATION

12.3 OVERALL DIMENSIONS LFPlus

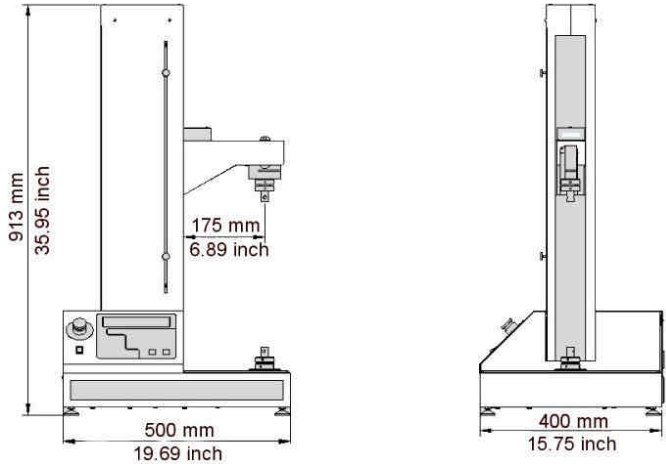

LFPlus with Load Cell - External Dimensions

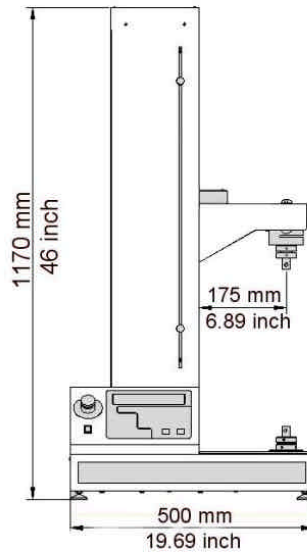

LFPlus Extended with Load Cell - External Dimensions

12.0 SPECIFICATION

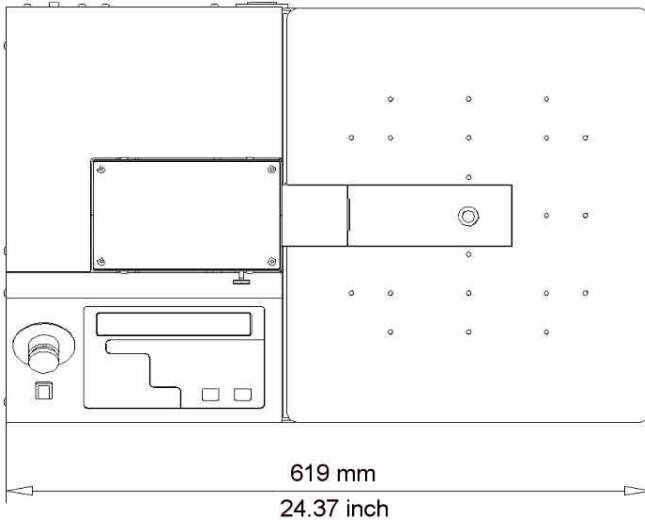

LFPlus with Ext. Table - Dimensions

12.0 SPECIFICATION

12.4 RS232 LEADS

MACHINE to PC Part No. 09/0639 (supplied).

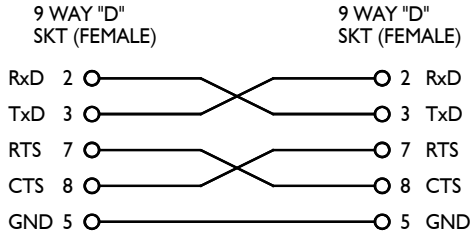

09/0639

Data rate is 57600 BAUD, 8 Bit, no parity, 1 stop Bit

MACHINE TO PRINTER Part No. 09/0721 (optional)

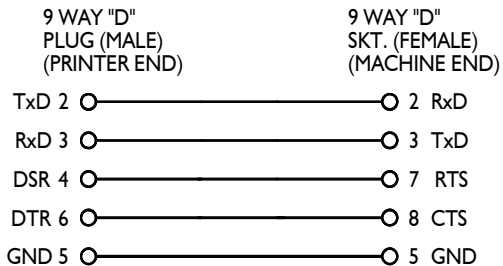

09/0721

Data rate is 9600 BAUD, 8 Bit, no parity, 1 stop Bit.

Note:

To maintain EMC compliance **ONLY** leads supplied by LLOYD INSTRUMENTS should be used. Check leads for signs of damage regularly. Replace leads that are damaged in any way.

AMETEK[®]

TEST AND CALIBRATION INSTRUMENTS

UK

Lloyd Instruments Ltd
Forum House
12 Barnes Wallis Rd
Segensworth East, Fareham,
Hampshire, UK
P015 5TT
Tel: +44 (0)1489486399
Fax: +44 (0)1489885118

America

Ametek Test & Calibration
Instruments - Americas
Harriman Business Center
1220 Washington Ave
Building 7A / Suite 300
Albany, NY 12226
Tel: (518) 689-0222
Fax: (518) 689-0225

Far East

Lloyd Instruments
Far East Representative Office
No7 Sherwood Place
Alexander Heights
6064 Perth
WESTERN AUSTRALIA
Tel: +61 8 9343 5725
Fax: +61 8 9343 5723

France

Lloyd Instruments SA
3 avenue des Coudriers
Zone d'activité de
l'observatoire
78180 Montigny-Le-
Bretonneux
FRANCE
Tel: +33 (1)30574774
Fax: +33 (1) 30575033

Germany

AMETEK Precision
Instruments
Europe GmbH
Rudolf-Diesel-StraBe 16
D-40670 Meerbusch
GERMANY
Tel: +49 (0)21599136-70
Fax: +49 (0)2159 9136-80

Singapore

AMETEK Singapore Private Ltd
10 Ang Mo Kio Street 65
#05-12 TECHPOINT
Singapore 569059
Tel: +65 484 2388
Fax: +65 481 6588

AMETEK Lloyd Instruments Limited has an on-going programme of design and development, which may alter product specification. Therefore AMETEK Lloyd Instruments Limited reserves the right to change specifications at any time without notice.

No part of this manual may be reproduced or transmitted in any form without prior permission of AMETEK Lloyd Instruments Limited.