

Chatillon® TD5 Series Crane Scales

Specification Sheet
SS-TD5-0310
March 2010

The CHATILLON® TD5 Series mechanical dynamometer may be used as a weighing tensiometer or crane scale. This precision weighing instrument features an easy-to-read 5-inch (127 mm) dial face with shatter-resistant dial cover in a strong aluminum housing. Available with pound or kilogram dial face, the TD5 Series accuracy is better than 1% of full scale. A manually engaged clutch “freezes” the pointer at its maximum reading for exact reading of peak weight. Needle bearings in shackles prevent brinneling under heavy loads and eliminate shackle misalignment. Mechanism sealed against dust and dirt. Oiling not required. Dynamometer is supplied with a Certificate of Calibration with Data traceable to NIST. Options include face guard, carrying case and hooks.

Features

- LB and KG Dials
- Rugged Cast Aluminum Housing
- 5-inch Reading Dial is Shatter Resistant
- Peak Weight Pointer
- 400% Safety Factor
- 2 Year Warranty
- Certificate of Calibration with NIST Data

Specifications

Accuracy:	±1% of Full Scale
Tare Capacity:	10% of Rated Capacity
Safe Overload:	150% of Rated Capacity
Ultimate Overload:	200% of Rated Capacity
Dial Resolution:	100:1
Full Scale Reading:	1 Dial Revolution
Operating Temp:	-50°F to 140°F (-45°C to 60°C)
Relative Humidity:	0 to 85%
Instrument Weight:	9 lbs (4 kg)
Shipping Weight:	12 lbs (6 kg)
Warranty:	1 year

Note: Weights are approximate.



Shown with optional Face Guard.

Ordering

Scale with Shackles

Model	Capacity	Length
TD5-00500	500 x 5 lb	13-1/4 in (337 mm)
TD5-01000	1000 x 10 lb	13-1/4 in (337 mm)
TD5-02000	2000 x 20 lb	13-1/4 in (337 mm)
TD5-05000	5000 x 50 lb	13-1/4 in (337 mm)
TD5-10000	10000 x 100 lb	15 in (381 mm)
TD5-20000	20000 x 200 lb	15 in (381 mm)

TD5-00500K	500 x 5 kg	13-1/4 in (337 mm)
TD5-01000K	1000 x 10 kg	13-1/4 in (337 mm)
TD5-02000K	2000 x 20 kg	13-1/4 in (337 mm)
TD5-05000K	5000 x 50 kg	15 in (381 mm)
TD5-10000K	10000 x 100 kg	15 in (381 mm)

With Eye Hook

Model	Capacity	Length
TD5-00500-EH	500 x 5 lb	19-13/16 in (503 mm)
TD5-01000-EH	1000 x 10 lb	19-13/16 in (503 mm)
TD5-02000-EH	2000 x 20 lb	19-13/16 in (503 mm)
TD5-05000-EH	5000 x 50 lb	19-13/16 in (503 mm)
TD5-10000-EH	10000 x 100 lb	26-5/16 in (668 mm)
TD5-20000-EH	20000 x 200 lb	26-5/16 in (668 mm)

TD5-00500K-EH	500 x 5 kg	19-13/16 in (503 mm)
TD5-01000K-EH	1000 x 10 kg	19-13/16 in (503 mm)
TD5-02000K-EH	2000 x 20 kg	19-13/16 in (503 mm)
TD5-05000K-EH	5000 x 50 kg	26-5/16 in (668 mm)
TD5-10000K-EH	10000 x 100 kg	26-5/16 in (668 mm)

With Swivel Hook

Model	Capacity	Length
TD5-00500-SH	500 x 5 lb	21-1/2 in (546 mm)
TD5-01000-SH	1000 x 10 lb	21-1/2 in (546 mm)
TD5-02000-SH	2000 x 20 lb	21-1/2 in (546 mm)
TD5-05000-SH	5000 x 50 lb	21-1/2 in (546 mm)
TD5-10000-SH	10000 x 100 lb	28-3/8 in (721 mm)
TD5-20000-SH	20000 x 200 lb	28-3/8 in (721 mm)

TD5-00500K-SH	500 x 5 kg	21-1/2 in (546 mm)
TD5-01000K-SH	1000 x 10 kg	21-1/2 in (546 mm)
TD5-02000K-SH	2000 x 20 kg	21-1/2 in (546 mm)
TD5-05000K-SH	5000 x 50 kg	28-3/8 in (721 mm)
TD5-10000K-SH	10000 x 100 kg	28-3/8 in (721 mm)

Dimensions

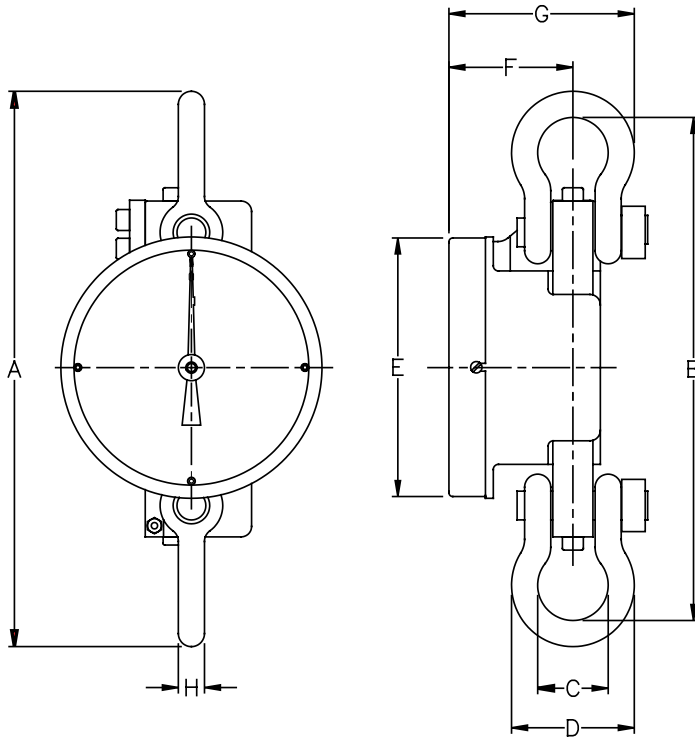

Dimensions with Shackles

Capacity		A	B	C	D	E	F	G	H
500 - 5000	(inch)	13-1/4	12	1-11/16	3	6-1/4	3-1/8	4-9/16	5/8
	(mm)	337	305	43	76	159	79	116	16
10,000 - 20,000	(inch)	15	13-1/4	1-7/16	3-1/4	6-1/4	3-1/8	4-3/4	7/8
	(mm)	381	337	37	83	159	79	121	22

Accessories & Options

Part No.	Description
13400	Eye Hook
13401	Eye Hook
13402	Shackle
13403	Shackle
13404	Swivel Hook
13405	Swivel Hook
SPK-WT12-CASE	Carrying Case
16026-1	Face Guard

Add suffix "FG" after model if optional face guard is required.

Optional Accessories



Swivel Shackles



Eye Hooks



Swivel Hooks