







		Range	Resolution
Humidity	% RH	10 to 95 %RH	0.1 %RH
	Temperature (thermister)	32 to 122°F	0.1°F
		0 to 50°C	0.1°C
Light *auto range	Lux	0 to 2,200 Lux	1 Lux
		1,800 to 20,000 Lux	10 Lux
	Ft-cd	0 to 204.0 Ft-cd	0.1 Ft-cd
		170 to 2,000 Ft-cd	1 Ft-cd
Temperature (Type K)		-148 to 2372°F	0.1°F
		-100 to 1300°C	0.1°C

		Range	Accuracy
Air velocity	80 to 5910 ft/min	$\leq 20 \text{ m/s} : \pm 3\% \text{ F.S.}$ $> 20 \text{ m/s} : \pm 4\% \text{ F.S.}$	
	0.4 to 30.0 m/s		
	1.4 to 108.0 km/h		
	0.9 to 67.0 mile/h		
	0.8 to 58.3 knots		
	32 to 122°F		
	0 to 50°C	$\pm 1.2^\circ\text{C}$	
Humidity	10 to 95 %RH	$< 70\% \text{ RH} : \pm 4\% \text{ RH};$ $\geq 70\% \text{ RH} : \pm (4\% \text{rdg} + 1.2\% \text{RH})$	
	32 to 122°F	$\pm 2.5^\circ\text{F}$	
	0 to 50°C	$\pm 1.2^\circ\text{C}$	
Light	0 to 20,000 Lux	$\pm 5\% \text{rdg} \pm 8 \text{dgt}$	
	0 to 2,000 Ft-cd		
Temperature (Type K)	-148 to 2372°F	$\pm (1\% \text{rdg} + 2^\circ\text{F})$	
	-100 to 1300°C	$\pm (1\% \text{rdg} + 1^\circ\text{C})$	

ft/min = feet per minute

m/s = meters per second

km/h = kilometers per hour

MPH = miles per hour

knots = nautical miles per hour

Ft-cd = foot candle

# Instrument Description

1. Power Button
2. Hold Button
3. Max/Min Button
4. Unit/Zero Button
5. °C/°F Button & Lux/Ft-cd Button
6. Function Button
7. Air Flow Sensor
8. Thermocouple Input Socket
9. R.H. Sensor
10. Light Sensor
11. LCD display
12. Battery Compartment/Cover
13. Wristlet

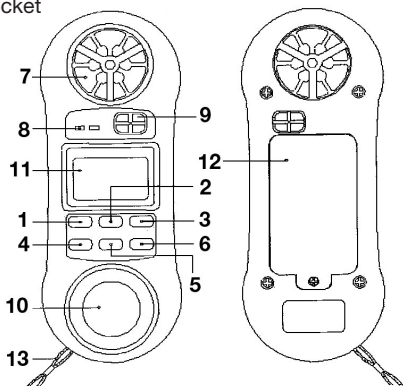

## Operating Instructions

### *Air Velocity Measurement*

1. Power on the instrument by pressing the Power Button
2. Select the Anemometer function by pressing Function Button
3. Press the Unit/Zero Button to select unit that you want and then face the Air Flow Sensor to the source of wind
4. Allow time for the reading to become stable and note the value indicated

## *Thermocouple Temperature Measurement*

1. Power on the instrument by pressing the Power Button
2. Plug a type K thermocouple probe in the Thermocouple Input Socket
3. Select the Temperature function by pressing Function Button
4. Contact the Thermocouple Sensor Head with the object being measured and the reading value will be displayed on the LCD display

## *Humidity & Ambient Temperature Measurement*

When the meter is applied in a new environment, it will take a few minutes to reach a stable condition

1. Power on the instrument by pressing the Power Button
2. Select the Relative Humidity function by pressing the Function Button
3. The reading value of relative humidity and temperature will be displayed on the LCD display

## *Light Measurement*

1. Power on the instrument by pressing the Power Button
2. Select the Light Measurement function by pressing the Function Button until the light value is displayed
3. Press the Lux/Ft-cd Button to select measuring unit Lux or Ft-cd

## *Zero Offset Adjustment of Light Function*

- For best results you should zero the light sensor prior to use in a dark environment. To achieve this, place the light sensor end of the meter under a desktop or flat surface to block any light. Press the Unit/Zero Button setting the meter indication to zero.
- The zero point can drift due to environment temperatures, battery power, as well as various other reasons. It is recommended that the zero be checked frequently using the above procedure.

## *Hold Function*

Pressing the Hold Button will freeze the current value with a HOLD symbol on the display. Press again to release the hold function.

## *Data Record Function*

The Data Record function records & displays the maximum and minimum reading values. Start the Data Record function by pressing the Max./Min. Button once. There will be a “REC” symbol on the display. With the REC symbol on the display:

1. Press the Max/Min Button once and the Max symbol along with the maximum value will appear on the display.
2. Press the Max/Min Button again, the “Min” symbol along with the minimum value will appear on the display.
3. To exit the memory record function, press the Max/Min Button continuously for at least 2 seconds. The display will revert to the current reading.
4. To clear the Max/Min value recorded by pressing the Hold Button once. The previously recorded Max/Min value will be lost and then revert to the REC function continuing to record.

## *Auto Power Off*

In order to prolong the battery life, the instrument has “Auto Power Off” function. The meter will switch off automatically if no buttons are pressed for around 10 minutes.

# Battery Replacement

When the left corner of the LCD display shows the low battery symbol, this indicates that replacement of the battery is then needed. However specification measurements could still be taken for another few hours before the meter becomes inaccurate.

1. Open the Battery Cover at the back of the meter and remove the battery
2. Replace with a 9V battery (alkaline or heavy-duty type) and reinstall the cover

For service on this or any other REED product or information on other REED products, contact REED Instruments at [info@reedinstruments.com](mailto:info@reedinstruments.com)

## Notes

---

---

---

---

---

---

---

---

---

---

---

---

---