



## Model 332

### Compact Load Cell

The high quality load cell model 332, is intended for permanent fitting into machines and installations of all kinds. The load cell is supplied with a precise pressure gauge 100 mm nominal diameter with zero point correction. A wide range of accessories are available to cover most applications.

# Technical Information

**Number of borings:**  
 2 parts each displaced by 180°  
 Version "B" (e.g. High-pressure hose, capillary tube, borings etc.) on request.

"A"-version; Load cell with attached display unit, without any accessories or options  
 "B"-version; Load cell with accessories or options



Model	Size	Nominal value	High-pressure hose (m)	Capillary tube (m)	Weight (kg)	Dimensions (mm)											
						øD1	øD2	øD3	øD4	H1	H2	H3	H4	H5	H6	L1	M1
332- 1 kN	I	1 kN	0,63	1	2	65	40	48	100	80	6,5	10	16	15	49	172	M6
332- 1,6 kN		1,6 kN															
332- 2,5 kN		2,5 kN															
332- 4 kN		4 kN															
332- 6,3 kN		6,3 kN	1,5	4													
332- 10 kN		10 kN															
332- 16 kN		16 kN	5	10													
332- 25 kN		25 kN															
332- 40 kN		40 kN															
332- 63 kN		63 kN															
332- 100 kN	100 kN																
332- 100 kN	100 kN																
332- 160 kN	II	160 kN	5	10	9	110	66	50	100	128	9	12	18	15	49	195	M8
332- 250 kN		250 kN															
332- 400 kN		400 kN															
332- 250 kN	III	250 kN	5	10	30	175	103	170	100	157	12	15	18	15	49	228	M12
332- 400 kN		400 kN															
332- 630 kN		630 kN															
332- 1 MN		1 MN															



14 North Peoria St, Suite B-101 | Chicago, IL 60607-2755  
 Phone 312.666.0595 | info@jlwinstruments.com

# Technical Information

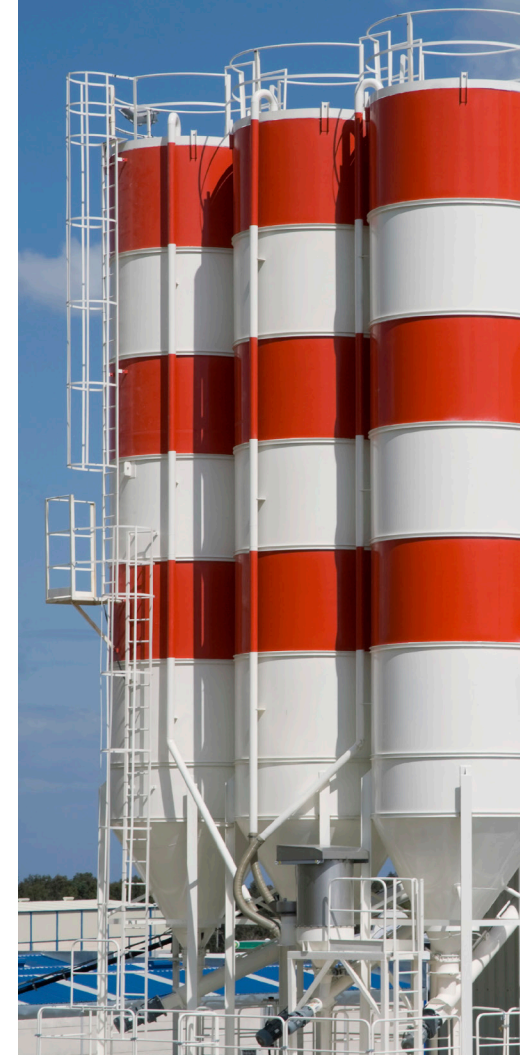
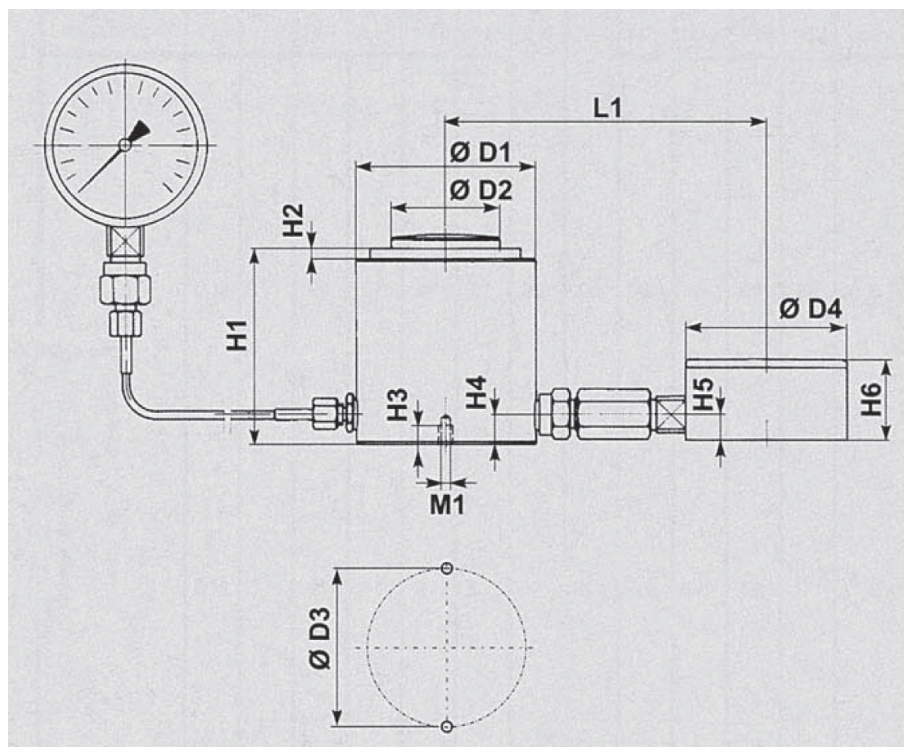

14 North Peoria St, Suite B-101 | Chicago, IL 60607-2755  
Phone 312.666.0595 | info@jlwinstruments.com



[www.ametektest.com](http://www.ametektest.com)

