

32-1137 REV 1

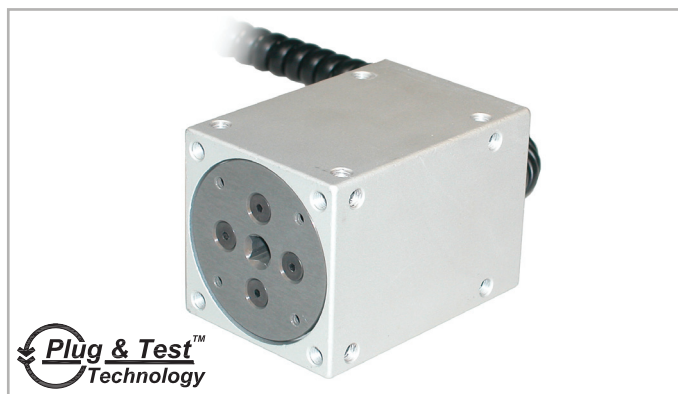

Series R52 smart sensors measure bi-directional torque for a wide variety of applications across virtually all industries. Calibrate torque tools, or use these sensors as components of a torque testing system. Tapped holes on every surface allow for easy mounting to a work bench or fixture. Capacities available from 10 ozFin to 100 lbFin [7 to 1150 Ncm]. Compatible with Mark-10 indicators (sold separately) through unique Plug & Test™ technology.

Specifications

Accuracy:	±0.35% of full scale + indicator
Safe Overload:	MR52-10Z - MR52-50Z: 300% of full scale MR52-12 - MR52-100: 150% of full scale
Weight:	1.2 lb [0.5 kg]

Dimensions in [mm]

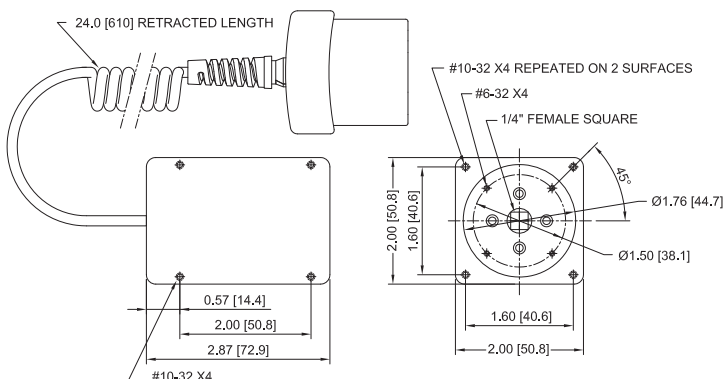

< Unique Plug & Test™ technology allows for interchangeable sensors to be used with a Mark-10 indicator. All calibration and configuration data is saved in the smart connector.



< The Plug & Test™ connector locks into the receptacle in the indicator when fully inserted. Dual buttons on the indicator housing release the connector for easy removal. Gold plated spring contacts ensure long lasting and reliable connection.

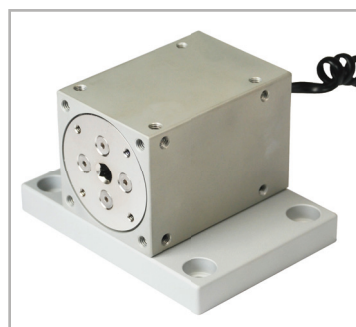

^ Series R52 torque sensors include threaded holes on all surfaces for flexibility in a variety of mounting configurations. Shown above with the optional AC1006 tabletop mounting kit.



^ A Series R52 torque sensor is shown with the optional AC1014 Jacobs chuck attachment.

Optional Items

AC1006	Mounting kit, tabletop, Series R52
AC1014	3/8" Jacobs chuck, Series R52

Capacity x Resolution

Model No.	With Models 7i & 5i indicators								With Model 3i indicator			
	lbFin	ozFin	lbFft	gFcm	kgFmm	Nmm	Ncm	Nm	lbFin	ozFin	kgFmm	Ncm
MR52-10Z	-	10 x 0.005	-	700 x 0.5	7 x 0.005	70 x 0.05	7 x 0.005	-	-	10 x 0.01	7 x 0.005	7 x 0.005
MR52-20Z	-	20 x 0.01	-	1400 x 1	14 x 0.01	140 x 0.1	14 x 0.01	-	-	20 x 0.02	14 x 0.01	14 x 0.01
MR52-50Z	-	50 x 0.02	-	3600 x 2	36 x 0.02	350 x 0.2	35 x 0.02	-	-	50 x 0.05	36 x 0.05	35 x 0.05
MR52-12	12 x 0.005	192 x 0.1	1 x 0.0005	-	-	-	135 x 0.1	1.35 x 0.001	12 x 0.01	192 x 0.2	-	135 x 0.1
MR52-50	50 x 0.02	800 x 0.5	4 x 0.002	-	-	-	570 x 0.5	5.7 x 0.005	50 x 0.05	800 x 1	-	570 x 0.5
MR52-100	100 x 0.05	1600 x 1	8 x 0.005	-	-	-	1150 x 0.5	11.5 x 0.005	100 x 0.1	1600 x 2	-	1150 x 1