

32-1132 REV 5



Hooks not included

Series R03 smart sensors are designed for tension and compression measurement applications in virtually every industry. Threaded holes on two sides can accept a variety of hooks and implements, making this sensor particularly well suited for inline tests. A shortened cable is available for mounting to an ESM1500LC, ESM303H, or ESM303 test stand (when equipped with optional AC1062 mounting kit\*). Capacities available from 0.25 to 100 lbf [1 to 500 N]. Compatible with Mark-10 indicators (sold separately) through unique Plug & Test™ technology.

## Specifications

<b>Accuracy:</b>	±0.15% of full scale + indicator
<b>Safe Overload:</b>	150% of full scale
<b>Weight:</b>	0.4 lb [0.2 kg]

## Dimensions in [mm]

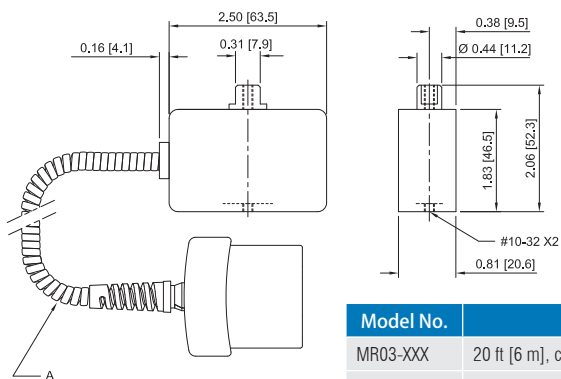

Model No.	A
MR03-XXX	20 ft [6 m], coiled, retracted
MR03-XXX-1*	10 in [254 mm], straight*

## Capacity x Resolution

Model No.	With Models 7i & 5i indicators							With Model 3i indicator			
	lbf	ozF	gF	kgF	N	mN	lbf	gF	kgF	N	
MR03-025*	0.25 x 0.0001	4 x 0.002	100 x 0.05	-	1 x 0.0005	1000 x 0.5	0.25 x 0.0002	100 x 0.1	-	1 x 0.001	
MR03-05*	0.5 x 0.0002	8 x 0.005	250 x 0.1	-	2.5 x 0.001	2500 x 1	0.5 x 0.0005	250 x 0.2	-	2.5 x 0.002	
MR03-2*	2 x 0.001	32 x 0.02	1000 x 0.5	1 x 0.0005	10 x 0.005	-	2 x 0.002	-	1 x 0.001	10 x 0.01	
MR03-5*	5 x 0.002	80 x 0.05	2500 x 1	2.5 x 0.001	25 x 0.01	-	5 x 0.005	-	2.5 x 0.002	25 x 0.02	
MR03-10*	10 x 0.005	160 x 0.1	5000 x 2	5 x 0.002	50 x 0.02	-	10 x 0.01	-	5 x 0.005	50 x 0.05	
MR03-20*	20 x 0.01	320 x 0.2	10000 x 5	10 x 0.005	100 x 0.05	-	20 x 0.02	-	10 x 0.01	100 x 0.1	
MR03-50*	50 x 0.02	800 x 0.5	25000 x 10	25 x 0.01	250 x 0.1	-	50 x 0.05	-	25 x 0.02	250 x 0.2	
MR03-100*	100 x 0.05	1600 x 1	50000 x 20	50 x 0.02	500 x 0.2	-	100 x 0.1	-	50 x 0.05	500 x 0.5	

\* Add suffix "-1" for shortened cable, for use on the ESM303, ESM303H, and ESM1500LC test stands.

Ex: MR03-50-1.

Test stand mounting hardware is included.



< Unique Plug & Test™ technology allows for interchangeable sensors to be used with a Mark-10 indicator. All calibration and configuration data is saved in the smart connector.



< The Plug & Test™ connector locks into the receptacle in the indicator when fully inserted. Dual buttons on the indicator housing release the connector for easy removal. Gold plated spring contacts ensure long lasting and reliable connection.



^ The load cell shaft includes flat surfaces as well as a threaded hole to accommodate attachments.



^ Optional AC1018 mounting kit adapts a Series R03 sensor to a Mark-10 test stand.

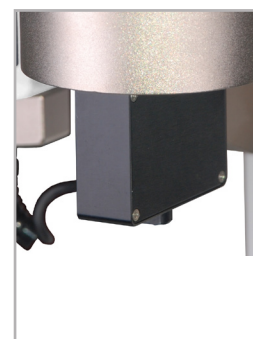

^ Series R03 sensor with shortened cable is shown mounted to an ESM1500LC test stand.\*

## Optional Items

<b>AC1018</b>	Mounting kit, Series R01/R03 to test stand (except ESM303, ESM303H, ESM1500, TSB100, and ESMH)
<b>AC1062</b>	Mounting kit, Series R01/R03/indicator to ESM303