



Series 4 digital force gauges are designed for tension and compression force testing in numerous applications across virtually every industry, with capacities from 0.12 lb to 500 lb (0.5 N to 2500 N). The gauges feature a sampling rate of 3,000 Hz, producing accurate results under a wide range of test conditions. Accuracy is $\pm 0.2\%$ of full scale, and resolution is 1/2000. A large, backlit graphics LCD displays large, legible characters, while the simple menu navigation allows for quick access to the gauges' many features and configurable parameters. Data can be transferred to a PC or data collectors via USB, RS-232, Mitutoyo (Digimatic), or analog outputs.

On-board data memory for up to 50 readings is included, as are statistical calculations with output to a PC. Integrated set points with indicators and outputs are ideal for pass-fail testing and for triggering external devices such as an alarm, relay, or test stand. The gauges are overload protected to 200% of capacity, and an analog load bar is shown on the display for graphical representation of applied force.



Shown with an ESM301 test stand and G1061 wedge grips

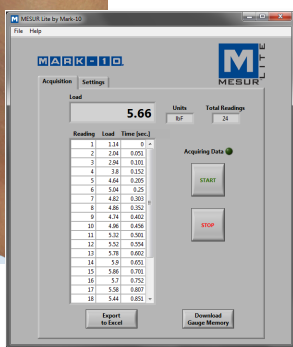

MESUR™ Lite data acquisition software is included with Series 4 gauges

An ergonomic, reversible aluminum design allows for hand held use or test stand mounting for more sophisticated testing requirements. Series 4 digital force gauges are directly compatible with Mark-10 test stands, grips, and software.

Series 4 gauges include MESUR™ Lite data acquisition software. MESUR™ Lite tabulates continuous or single point data from Series 5 and 4 gauges. Data saved in the gauge's memory can also be downloaded in bulk. One-click export to Excel button easily allows for further data manipulation.

Features

- 3,000 Hz sampling rate
- USB, RS-232, Mitutoyo, and analog outputs
- Large backlit graphic display
- 50-point data memory with statistics and outputs
- Live load bar graph with set point markers
- Programmable set points, with indicators and outputs
- Peak readings and set points always displayed
- Configurable audio alarms and key tones
- 5 selectable units of measurement
- MESUR™ Lite data collection software included

Display Indicators

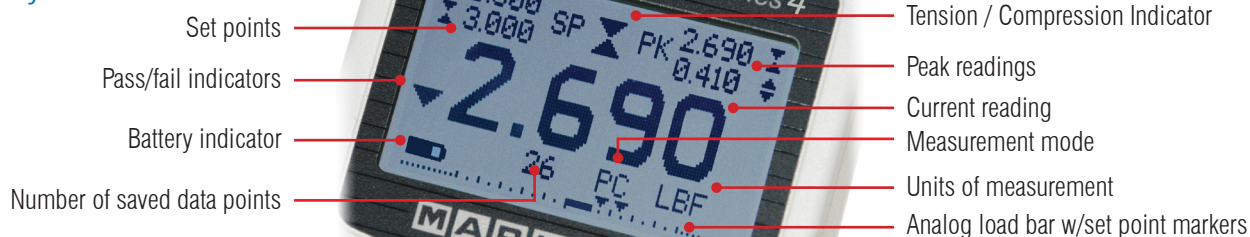

Focus on Engineering: Reversible Housing

Display and keypad are upright

Shaft down

Housing separates into reversible halves, electrically connected by gold-plated spring contacts.

Shaft up

Reversible housing allows the gauge to be handheld or mounted to a test stand.

The display and keypad remain upright.

Specifications

Accuracy:	±0.2% of full scale ±1 digit
Sampling Rate:	3,000 Hz, pulse response of 1/1,500 sec. minimum
Power:	AC or rechargeable battery. Multi-step low battery indicator is displayed, gauge shuts off automatically when power is too low.
Battery life:	Backlight on / off: up to 7 / 24 hours of continuous use
Outputs:	USB / RS-232: Configurable up to 115,200 baud. Mitutoyo (Digimatic): Serial BCD suitable for all Mitutoyo SPC-compatible devices. Analog: ±1 VDC, ±0.25% of full scale at capacity, General purpose: Three open drain outputs, one input. Set points: Three open drain lines.
Configurable settings:	Digital filters, outputs, automatic shutoff, default settings, key tones, audio alarms, calibration
Safe overload:	200% of full scale (display shows "OVER" at 110% and above)
Weight:	M4-012 - M4-100: 1.0 lb [0.45 kg] M4-200 - M4-500: 1.2 lb [0.54 kg]
Load cell deflection:	All models 0.010 [0.25], except 0.005 [0.13] for M4-012
Included items:	Carrying case, chisel, cone, V-groove, hook, flat, extension rod, AC adapter, battery, quick-start guide, USB cable, resource CD (USB driver, MESUR™ Lite software, MESUR™ gauge DEMO software, and user's guide), NIST-traceable certificate of calibration with data.
Environmental requirements:	40 - 100°F, max. 96% humidity, non-condensating
Warranty:	3 years (see individual statement for further details)

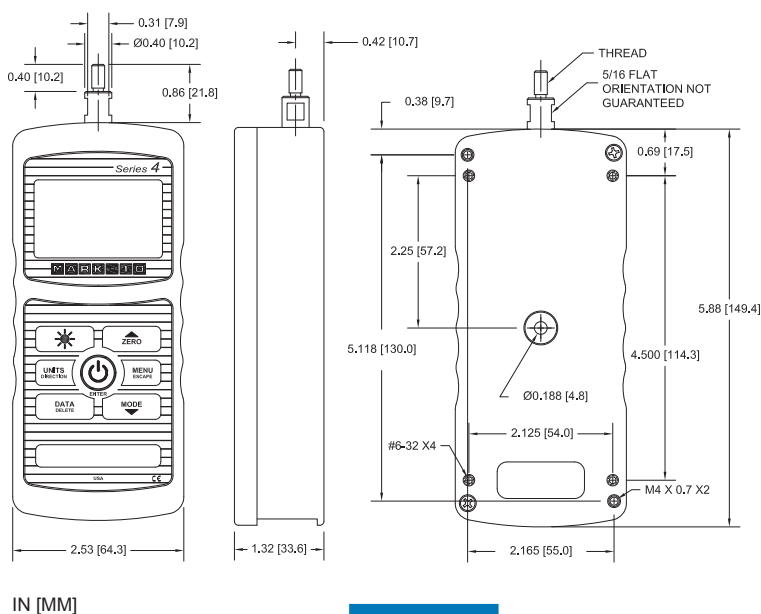

IN [MM]

	Thread
M4-012 - M4-100	#10-32 UNF
M4-200 - M4-500	5/16-18 UNC

Capacity & Resolution

Model	lbF	ozF	kgF	gF	N	kN	mN
M4-012	0.12 x 0.00005	2 x 0.001	-	50 x 0.02	0.5 x 0.0002	-	500 x 0.2
M4-025	0.25 x 0.0001	4 x 0.002	-	100 x 0.05	1 x 0.0005	-	1000 x 0.5
M4-05	0.5 x 0.0002	8 x 0.005	-	250 x 0.1	2.5 x 0.001	-	2500 x 1
M4-2	2 x 0.001	32 x 0.02	1 x 0.0005	1000 x 0.5	10 x 0.005	-	-
M4-5	5 x 0.002	80 x 0.05	2.5 x 0.001	2500 x 1	25 x 0.01	-	-
M4-10	10 x 0.005	160 x 0.1	5 x 0.002	5000 x 2	50 x 0.02	-	-
M4-20	20 x 0.01	320 x 0.2	10 x 0.005	10000 x 5	100 x 0.05	-	-
M4-50	50 x 0.02	800 x 0.5	25 x 0.01	25000 x 10	250 x 0.1	-	-
M4-100	100 x 0.05	1600 x 1	50 x 0.02	50000 x 20	500 x 0.2	-	-
M4-200	200 x 0.1	3200 x 2	100 x 0.05	-	1000 x 0.5	1x 0.0005	-
M4-500	500 x 0.2	8000 x 5	250 x 0.1	-	2500 x 1	2.5 x 0.001	-

All models include 110V AC adapters.

Add suffix 'E' for euro plug (220V), 'U' for UK plug (220V) or 'A' for Australian plug (220V).

Ex: M4-05E, M4-100U, M4-500A.