

RELAXONCHAIR

ION-3D

USER MANUAL

Ver. 3

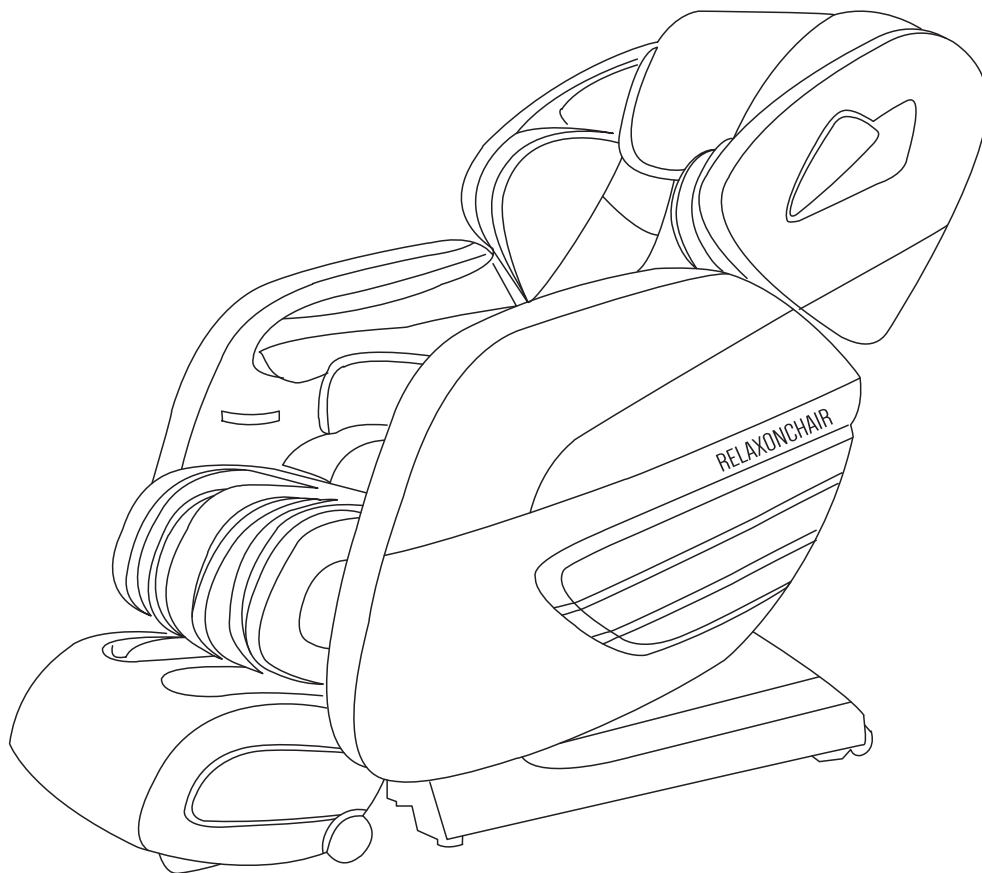

Please read SAFETY INSTRUCTIONS carefully before using the chair.

ION - 3D

Function Introduction

1. With the innovative, patented massage mechanism, it is capable of utilizing a variety of different techniques such as kneading, tapping, knocking, shiatsu, etc. It imitates the human hand with the use of the 3D technology, allowing the massage chair to become more dynamic and fluid much like a professional massage therapist.
2. With acupoint tracking detection functions, it can provide a specific and accurate massage that is suitable for different heights and sizes of users.
3. Combined with ergonomics and a long L-shaped curve guide, you can fully enjoy a head to thigh massage to quickly relieve the effects of spinal pressure.
4. One-button zero-gravity function can effectively relieve the pressure on the spine and joints, so that you may experience the benefits of true zero gravity.
5. With space-saving technology, the massage chair only requires a back area for 3.5" of recline. By allowing the chair to slide forward as the chair reclines, it can be placed almost anywhere in the home.
6. Comes with a fully equipped footrest of rolling and airbag functions to stimulate the feet.
7. The legs are able to be compressed with multiple sets of airbags, and promotes blood circulation through the use of airbags.
8. The armrests are able to cover the entire length of the arm with air compression massages, which promotes blood circulation and relieves hand numbness.
9. Air bags strategically located on the chair to provide a gentle squeezing massage to relax stressed muscles and quickly eliminate fatigue.
10. The footrest is able to extend and retract up to a length of 7", allowing the chair to accommodate most users' heights.
11. The chair comes equipped with a user-friendly remote controller with a high-resolution LCD graphic that shows massage functions and techniques in real time.
12. With Chinese medicinal heating therapy on the waist, heat is distributed throughout the hips relieving back pain and promoting blood circulation.

Thank you for choosing the RELAXONCHAIR ION-3D Massage Chair. Please read this manual very carefully before use of the product. Keep this manual for future reference. Please pay attention to the SAFETY INSTRUCTIONS.

Note: We reserve the right for the design to be changed. It is subject to change without notice. The pictures used in this manual are just for reference, and we ask you to please look at the actual product.

Table of Contents

PREPARATION

Safety Instructions	1
External Structure Parts	5
Internal Structure Parts	6
Mechanical Components	7

INSTALLATION

Installation	9
--------------------	---

MESSAGE OPERATION

Adjustments Before Massaging	13
Manual Control	16
Operation Instruction.....	21
Function Illustrations	22
After Massage	24

MAINTENANCE

Cleaning & Maintenance	25
------------------------------	----



OTHERS

Malfunction Guide	26
Technical Data	27





1 SAFETY INSTRUCTIONS

- Please read this manual carefully to ensure that the installation and operation of the massage chair is correct.
- “Safety Instructions” is provided in both Warning and Cautions for important safety information.



Both warning and caution signs should not be taken lightly. We ask that you please refrain from doing any of these to prevent damage and loss.

 Warning	This sign indicates possible cause of death or hurt to the body.
 Caution	This sign indicates possible injury or damage to things.

SYMBOL MEANING





	This sign indicates that you should NOT do this.		This sign indicates that disassembly is forbidden.
	This sign indicates instructions for operating.		This sign indicates the correct operation of a cable.



- The following should be kept for any further references.

 Warning		
	People who are not suitable to use the chair	<ul style="list-style-type: none"> • Osteoporosis patient. • People with heart disease including embedded pacemakers or other medical electronic devices inside the body. • For pregnant women or people not healthy, please consult doctor before use. • Patients with a high fever. • Perceptual disabilities patients. • People over 80 years old. • Kids/children without supervision. • People under the influence. • People who are still wet.
	Accident /injury	<ul style="list-style-type: none"> • Make sure there are no kids, pets or other objects around (behind, under, or in front of) the chair at the moment of backrest, leg-rest up & down or leg-rest retraction & extension from reclining position. • If your body feels sick or weird during the operation of the massage chair, please stop the massage, and go consult your physician. • Please refrain from giving the head a strong massage. • The chair is not designed to massage the belly nor knees. • Children and/or pets should not be within the vicinity nor in the chair while the chair is in operation. • Standing nor sitting on the backrest and armrest is not allowed. • If you have sensitive to heat, please exercise caution when using the heating function.







SAFETY INSTRUCTIONS



2

 Warning		
	Fire and electric shock	<ul style="list-style-type: none"> ● Insert the plug of the chair into correct and suitable power socket. ● Make sure the plug is completely inserted into the socket to reduce short circuit or fire risk. ● Unplug the power when not in use, stop all massage functions and turn off on/off key before unplugging.
	Accident	<ul style="list-style-type: none"> ● It is prohibited to use the massage chair while any items covered the massage chair ventilation holes. ● Massage cushions of the chair are not allowed to fold for storage. ● The machine is forbidden for no-load running for a long time.
	Fire and electric shock	<ul style="list-style-type: none"> ● Power cord, plug, socket cannot be used in broken or loose contact condition. ● Do not use other electric power except rated voltage in case of fire, electric shock or any breakdown. ● Any broken, re-process, knotted, twisted power cord or pressed under heavy cargo is not allowed to use.
	Disassembly and maintenance	<ul style="list-style-type: none"> ● If the chair works dysfunctional, or is broken, splashed with water or falls into water, please have it repaired by professional repairman or send the chair to assigned service agent. Self-modification, disassembly or maintenance is forbidden. ● If power cord or plug is damaged, please don't replace it yourself, please contact us or appointed dealer for replacement. ● To avoid electric shock or body hurt, please don't open or disassemble any part of the chair, there is not any attached part of the chair for maintenance by customers. ● Check leather or cloth material on the back and other areas is broken or not. If broken, even though it is small, please stop using the chair, unplug the power and have it repaired

 Caution		
	To Avoid Sudden Falling	● Please make sure that the area underneath the chair is flat and level.
	To Prevent Collision with Objects	● Please ensure that the chair has at least 3.5" of space in the back, and that objects are not in the way of the chair's recline.
	Long Massage Sessions	● The suggested time for a massage is 20 minutes. A long, continuous massage while being seated in the massage chair may cause uncomfortableness.
	To Avoid Accidents/Injuries	● Before use, please check to ensure that everything is in the correct position.
		● The remote control should be safely tucked away in the remote pocket. Arbitrarily putting away the remote control could cause damage due to the remote control being squeezed and/or dropped.
Turning on the Power	● Ensure that the power switch is on the OFF button before inserting the plug into the power socket.	
		● Please check to make sure that the controls/massage chair is powered OFF before removing the plug for the outlet.

3 SAFETY INSTRUCTIONS

 Caution		
	To Reduce Short Circuits and Avoid Fire Hazards	<ul style="list-style-type: none"> ● Make sure that the plug is completely inserted into the socket.
	To Avoid Electric Shock	<ul style="list-style-type: none"> ● Check the power cable and remote control wires for any signs of wear and tear. ● Properly plug in the cables into their respective sockets. Make sure that none of the wires are bent nor cut off. 
	To Avoid Accidents/Injuries	<ul style="list-style-type: none"> ● Don't press with hands or step on the massage heads with feet. ● Don't put hands between the working massage heads. ● Don't put hands or feet in the gap of mechanical parts. ● Don't drop or embed anything into the slot of massage chair. ● Don't stand or sit or put anything on the backrest, armrest or footrest. ● Don't move the chair during operation. ● Don't stand on the chair during operation. ● Don't pull out the plug or turn off the power during operation. ● Don't put your hands or head between leg-rest or beneath. ● Don't use the massage chair while wearing hair ornaments. ● Don't put hard things in pocket when take buttocks and huckle massage. ● Don't sit or press on the backrest when the chair is in reclining position. ● Don't use the chair with bare skin or very thin clothing. Thin clothing may provide greater massage effects, but it may cause irritation to the skin.
	To avoid fade, discolor on upholstery or hardened, deteriorated on PU.	<ul style="list-style-type: none"> ● Keep the chair away from heat, wet, sharp things and corrosive, inflammable, explosive environment. ● To use electric blanket or other heating products on the chair is forbidden.
		<ul style="list-style-type: none"> ● Keep the chair away from stove or other heating products. ● Don't put the chair directly under the sun or other high temperature places. ● Don't put in the space of dust serious or corrosive gas environment. ● Don't put the chair in a small space places or use in the bad air circulation places.
		<ul style="list-style-type: none"> ● Don't use the chair outdoor.
	To avoid leakage or electric shock.	<ul style="list-style-type: none"> ● Don't use or store the chair in the wet environment like nearing the swimming pool, or bathroom. ● Keep the chair and remote control dry all the time.

 Caution		
	To avoid electric shock or fire hazard.	<ul style="list-style-type: none"> • Unplug the power before cleaning the chair. • Unplug the power after using the chair.
	To avoid accidents.	<ul style="list-style-type: none"> • Unplug the power when any damage on the power. • Hold the plug to unplug the power but not try to pull the wire to unplug the power.
	To avoid damage or accidents when power on again.	<ul style="list-style-type: none"> • Please turn off the power switch and unplug the power after massage. • Unplug the power immediately when electricity goes off.

 Warning	
<ul style="list-style-type: none"> • Prohibition use if the chair was wet. • No need to use for the baby and the man cannot provide by themselves. • The chair surface with heating function, the people should take care if he don't feel the hot sensitive well. 	

GROUNDING INSTRUCTION

The chair is equipped with a cord with a built-in grounding conductor. The plug must be plugged into an appropriate socket in order to ensure that it is properly installed and matches the plug.

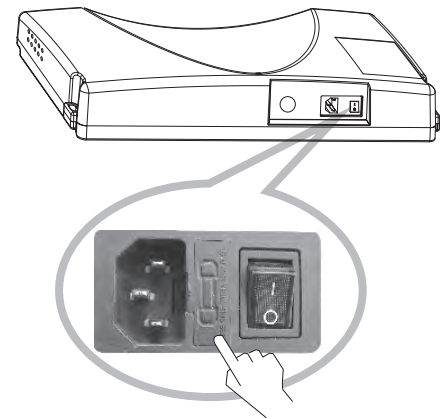

REPLACING THE FUSE

When the fuse has burned out, please turn off the power switch located at the back of the chair. Open the lid of the cover, which is covering the switch box. Replace the old fuse with the new one. Then place back on the cover.

 <p>Earth wire is not allowed to be in these places</p>	<p>Gas pipe: probably cause explosion or fire. Phone wire and lightning rod: probably cause electric shock and fire when thundering. Water pipe: earth wire is useless where there are plastics.</p>
---	--

5

EXTERNAL STRUCTURE PARTS

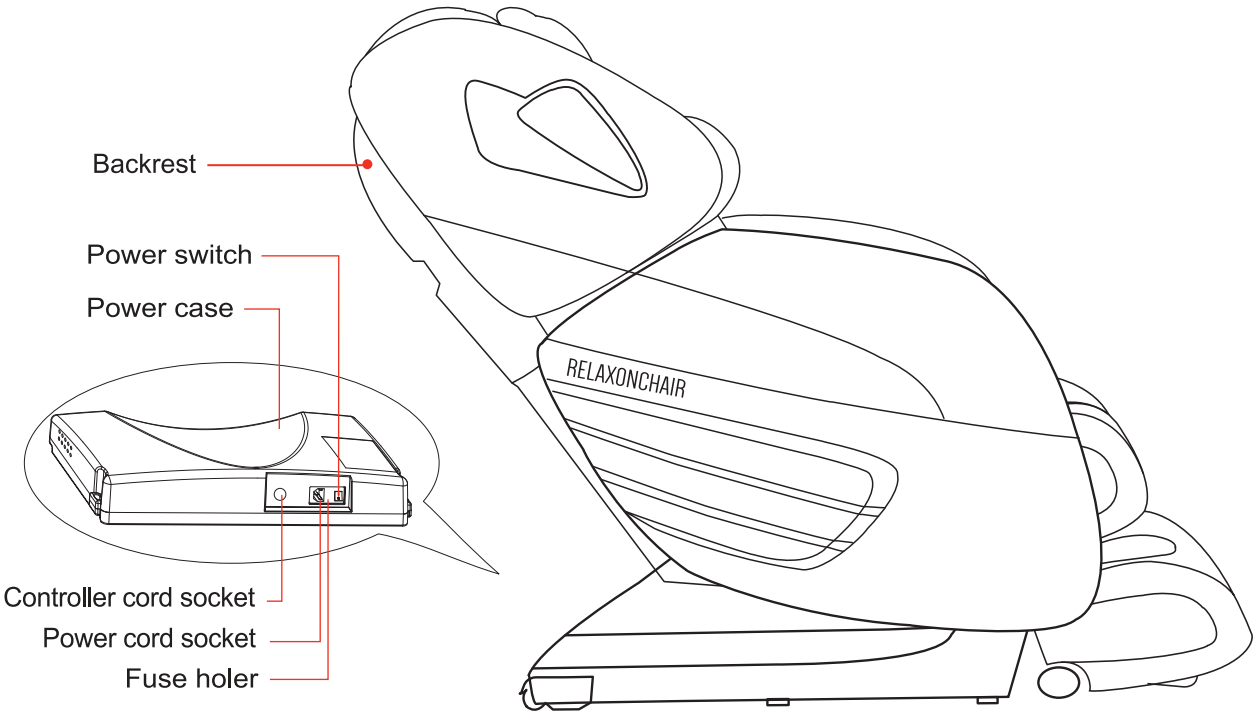
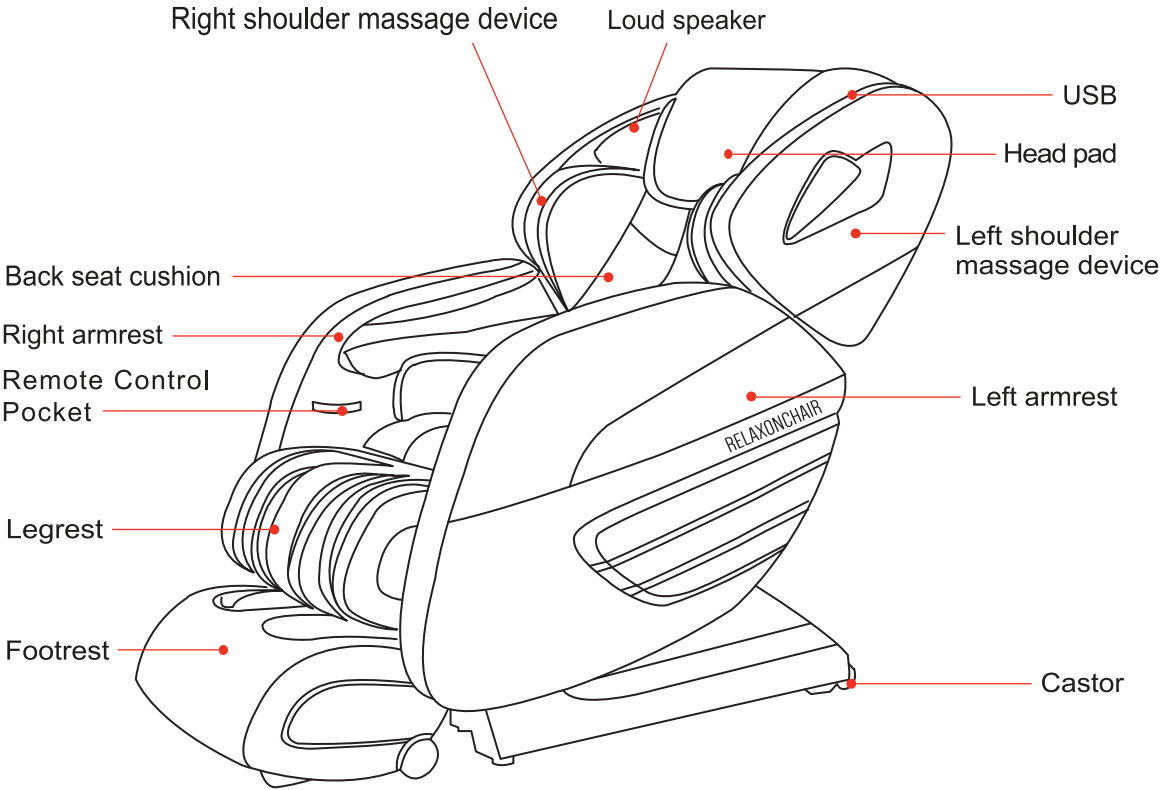

INTERNAL STRUCTURE PARTS

6

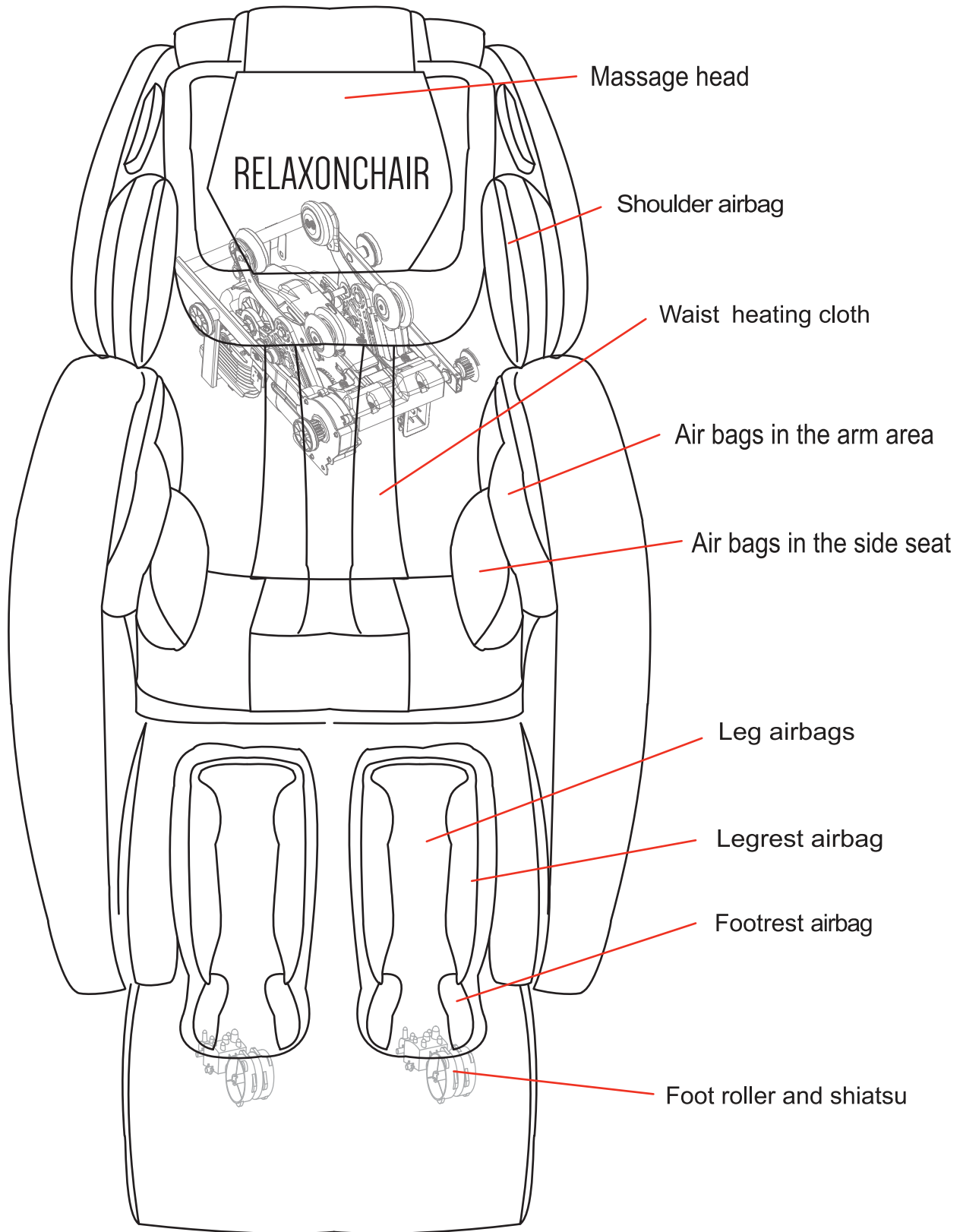

7

MECHANICAL COMPONENTS

MECHANICAL COMPONENTS DIAGRAM

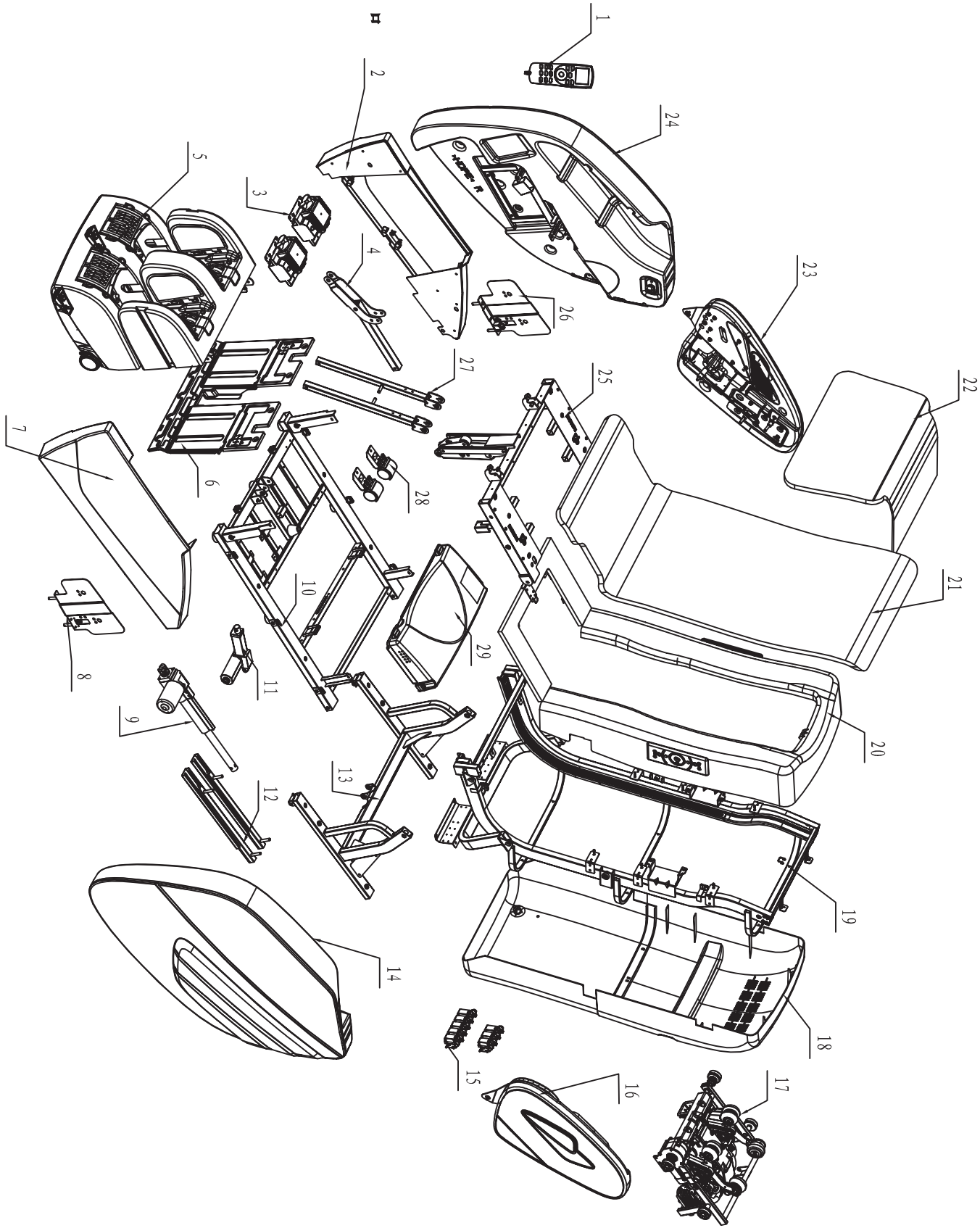

MECHANICAL COMPONENTS

8

MECHANICAL COMPONENTS LIST

NO	Name	Qty	NO	Name	Qty
1	Remote control	1	22	Pillow	1
2	Right side fender	1	23	Right shoulder massage assembly	1
3	Air pump assembly	2	24	Right armrest assembly	1
4	Connecting rod	1	25	Seat frame surface assembly	1
5	Legrest & footrest	1	26	Right side of seat airbag assembly	1
6	Front fender	1	27	Seat support bar	2
7	Left side fender	1	28	Castor	2
8	Left side of seat airbag assembly	1	29	Power case assembly	1
9	Backrest electric actuator	1			
10	Bottom seat frame assembly	1			
11	Footrest electric actuator	1			
12	Sliding rail	2			
13	Top seat frame assembly	1			
14	Left armrest assembly	1			
15	Electric magnetic valve 5 valve and 3 valve	1set/each			
16	Left shoulder massage device	1			
17	Massage machine	1			
18	Back cover assembly	1			
19	Back frame assembly	1			
20	Backrest plastic front cover and seat plate assembly	1			
21	Back and seat cushion	1			

9 INSTALLATION

STEP 1: REMOVING THE CHAIR

1. Lift out from the main packaging carton (BOX #1): Take out the shoulder carton, legrest (BOX #3), left and right airbags (BOX #2) of the seat, back seat cushion, pillow, power cord, hand controller from the main carton.
2. Take out the massage devices of the left and right shoulders from shoulder carton, when you take it out, grab the left and right sides of the shoulder massage device with two hands slowly, and put on table or ground. (Do not scratch it.)
3. Take out the left, right armrest from the box carton. Be sure to hold onto the two sides of the armrest and take them out slowly. (The armrest is placed upside down in the box). Place the armrest flat on the table or ground (be careful not to scratch the armrests).
4. Lift out the legrest from carton (when lifting, hold the front and back sides of the legrest with two hands).

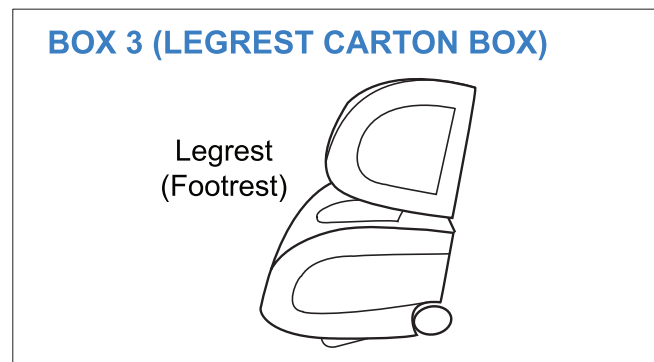
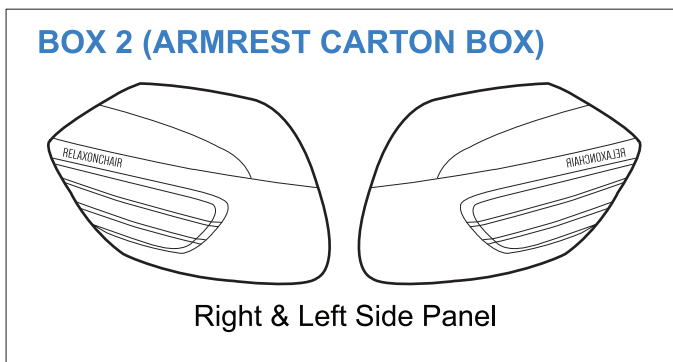
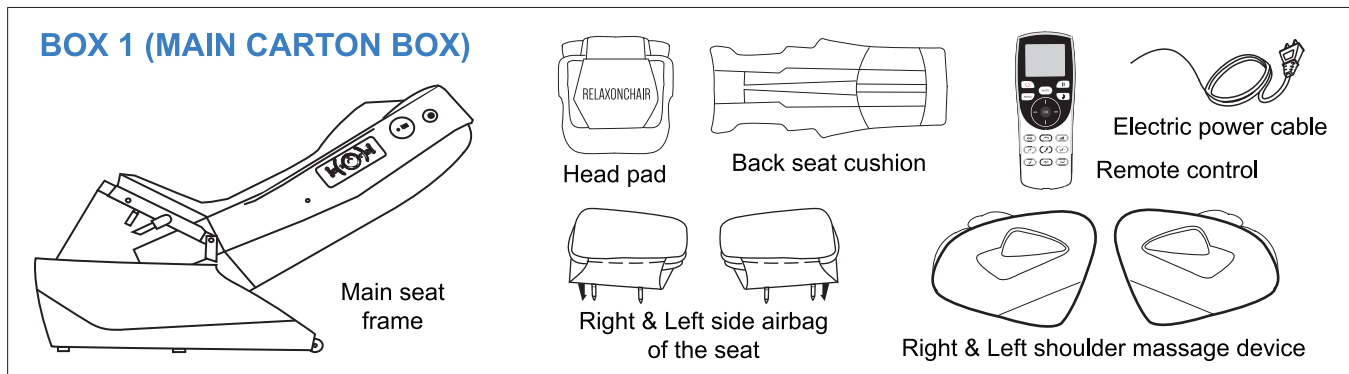

STEP 2: INCLINE MASSAGE CHAIR TO ORIGINAL POSITION

After removing the main body of the chair (BOX #1) :

1. Take out the power cord, insert one end into the socket on power box behind chair and insert other end into power outlet.
2. Turn on the power switch located on power box on the massage chair (backrest will go up and seat will go down).
3. After backrest reclines, turn off the power switch, then unplug the power cord. (Refer to STEP 8 after the assembly).

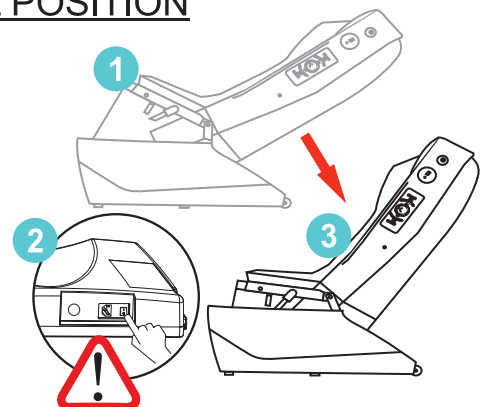

STEP 3: ASSEMBLING THE REGREST

Installing the legrest to the main body of chair

1. Unscrew the bolt from hanger on legrest (see image below to locate hanger).
2. Connect 3 air pipes on legrest with corresponding colored air tubes on the main body of chair. (from left to right = white, green, and black).
3. Connect power line to the power socket tightly.
4. Raise the AXIS cover on hangers, then raise the legrest, attach axis into the hangers on the main body of chair (see image 4 below).
5. Put down the axis cover and screw on bolts tightly.

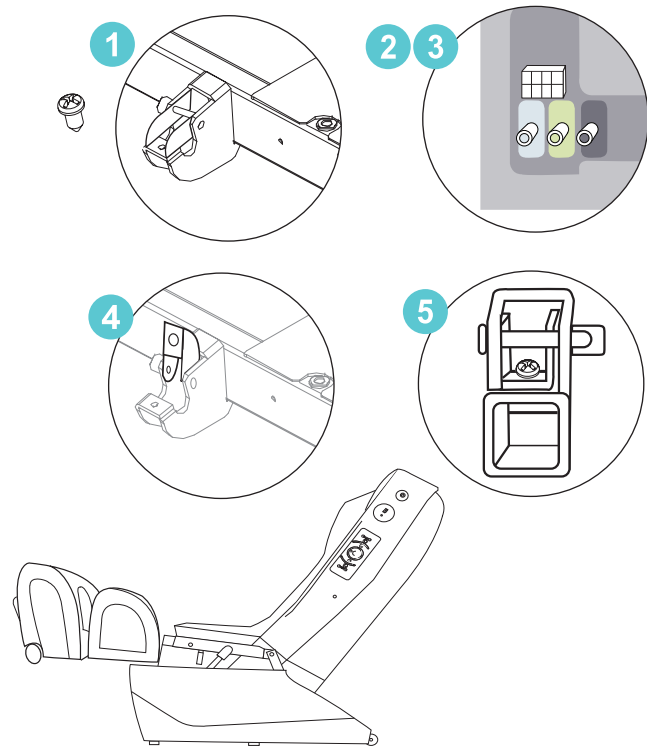

STEP 4: ASSEMBLING THE LEFT AND RIGHT ARMREST

1. Unscrew the M6 bolts on the seat frame with a cross screwdriver.
2. Line up the armrest with the small rod toward the middle of the chair. Then slowly push in the armrest.
3. Insert the square tube on the armrest into the side piece of the main seat frame (shown below).
4. Slightly move the armrest to make the front and back panels match the bolt holes on the corners of the seat metal frame. Then screw the M6 bolts into the holes.
5. Connect air hose from armrest to the same colors on the seat.

Be careful when assembling air pipes and avoid squeezing the pipes.

Disassembling the armrest:

Disconnect the air pipes between the seat and armrest, unscrew the four screws on the seat, then lift up the front of armrest (remove square tube in armrest from the plate of seat frame). Then press the button on the fixed hole (back of the armrest) and pull the ends of armrest at the same time. Remove the fixed hole from fixed bolt on side of backrest.

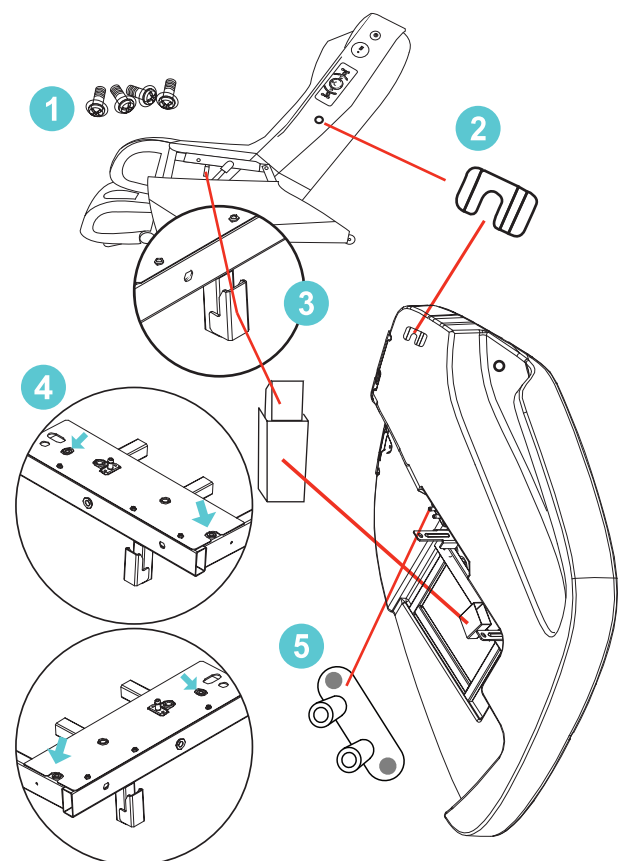

11 INSTALLATION

STEP 5: ASSEMBLING LEFT/RIGHT SIDE AIRBAGS AND CONNECTING REMOTE CONTROL

1. Take out seat side airbag, make sure the side with zipper faces towards the seat, align the two cylindrical pins to the two holes on the seat frame (shown below). Then press down straight and make sure connection is secure. (Ensure air hose connectors and lock hooks are connected firmly)

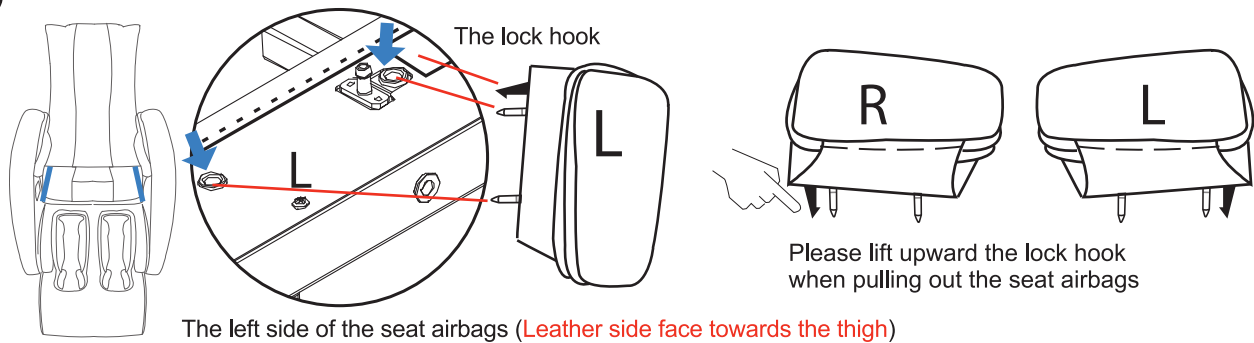

2. Take out the remote control, insert remote connector into the power box socket behind the chair, then place remote into the pocket in the right armrest.

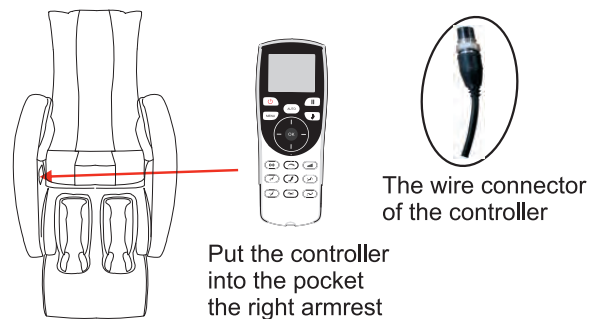

STEP 6: ATTACH BACKSEAT CUSHION AND HEADPAD

Attach cushion and headpad onto the backrest and connect both parts with the zipper and Velcro

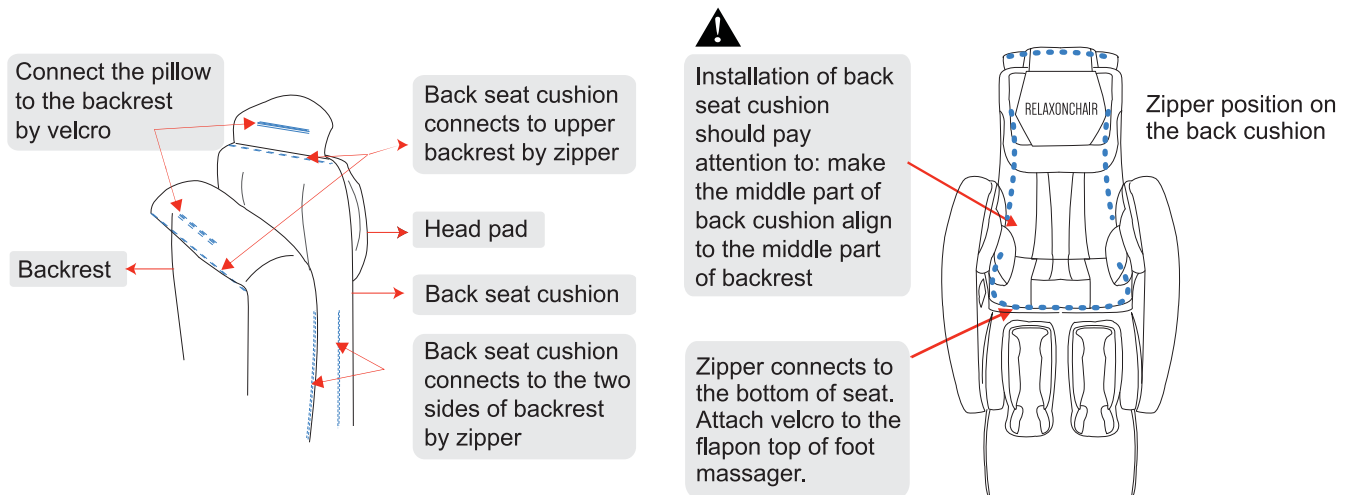
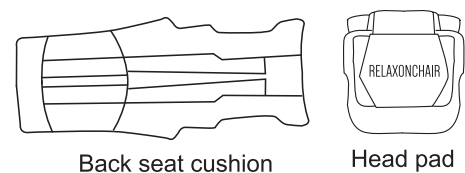

STEP 7: INSTALLING LEFT/RIGHT SHOULDER MASSAGE DEVICE

1. Before installing shoulder massage device, unscrew bolts fixed at the inside rear of armrest (as shown below)
2. Use 2 hands to lift and position the shoulder device for installation.
3. Connect the speaker wires and air tubes in the shoulder device to the backrest.
4. Match up the axle holes on the shoulder piece with the axle inserts on the backrest. Press the axles into the holes.
5. The two bottom axle holes on shoulder piece should be aligned with two inserts on the backrest (see image on the right).
6. After all holes and shafts are aligned firmly, shift the shoulder device down until it does not move any further.
7. Unzip the shoulder device airbag, then locate and align the bolt hole underneath the airbags with the bolt hole on the armrest. Screw in the bolt, and then zip the device airbag into the device to complete the installation.
8. Repeat the above steps to install the other side of the shoulder device.

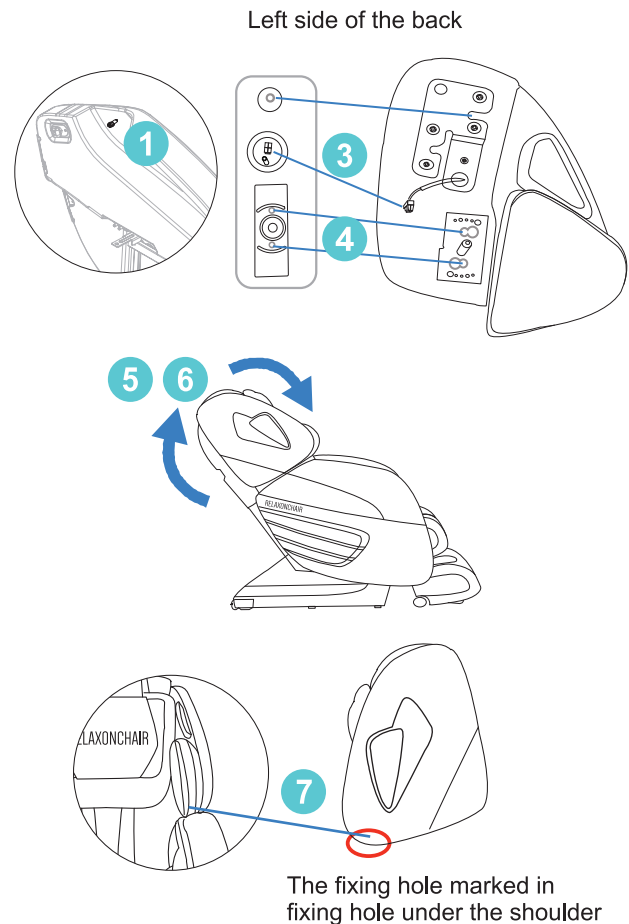

STEP 8: AFTER ASSEMBLING

After assembly is finished, please operate the chair in the following order:



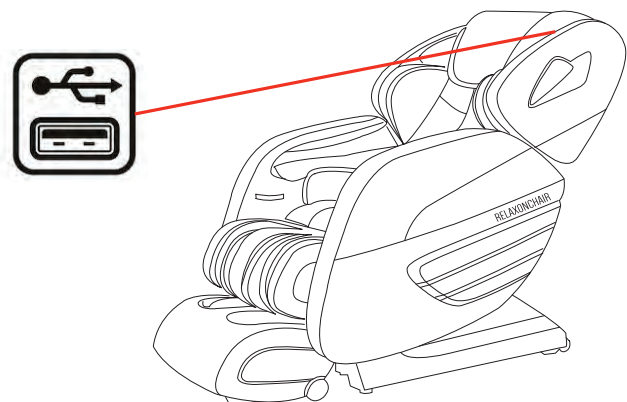
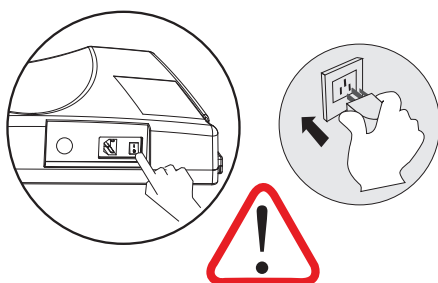

1. Plug the power cord in the power box as shown in the picture to the right.
2. Switch on the power on back of the chair.
3. Insert USB device into the USB input on the left shoulder device



13

ADJUSTMENTS BEFORE MASSAGING

CHECK ENVIRONMENT

 Caution		• Don't operate the chair in wet environments in order to avoid leakage or electric shock.
		• Don't operate under direct sunlight or near heating sources in order to avoid upholstery deterioration.
		• Please operate the chair on a flat surface in order to avoid falling, injuries, unnecessary noise, etc.

• Check Places in Front

Check the areas when back and leg extending, make sure no people, pets or other things around.

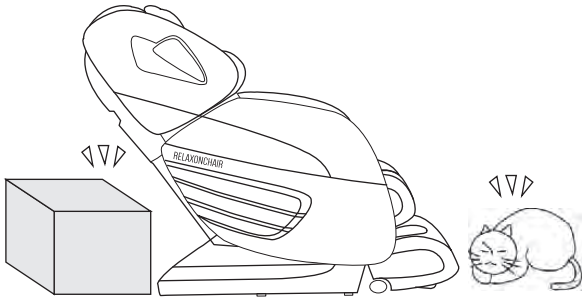

• Space Size for using the chair

The chair requires at least 3.5 inches from the back of the chair to the wall in order to accommodate for the full recline of the chair.

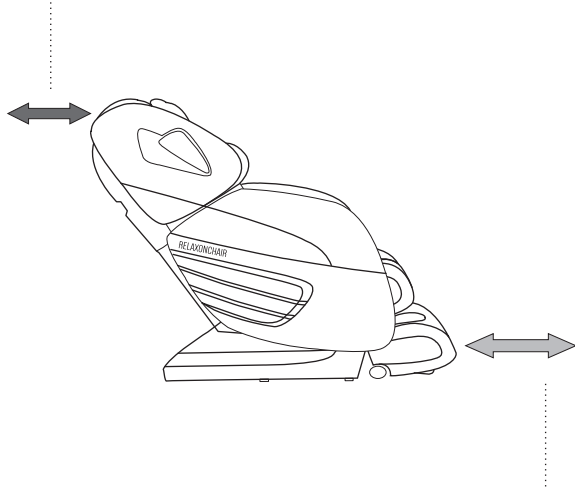

The chair requires at least 12 inches in front of the leg in order to accommodate for the full recline of the chair.

• Check Power Cable, Plug

1. Clean the dust on plug on time. (using dry cloth).
2. No damage, re-do, bend, stretch, tie or press with heavy thing (especially can't be pressed by the chair) on power cable.

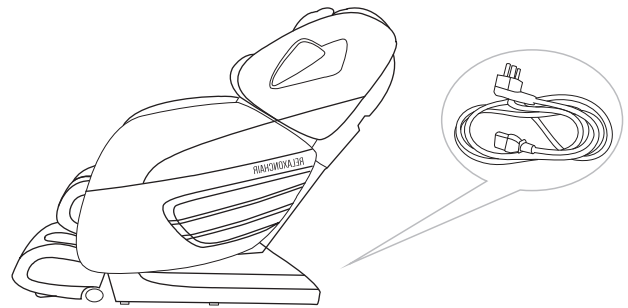

• Check Surroundings

1. Check any person or things in every direction.
2. Check the space size.

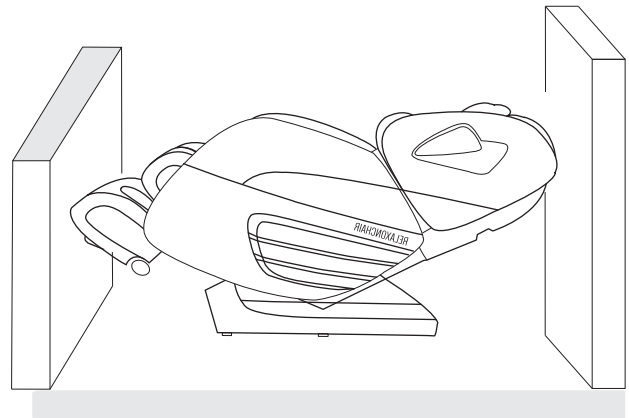

ADJUSTMENTS BEFORE MASSAGING 14

HOW TO MOVE MASSAGE CHAIR

 Caution

- Don't move the chair while it is in operation in order to prevent accidents or damages.

• Preparing to Move

- Bind the cables and put them in the seat to avoid damage when moving.
- If you plump the chair, it may damage the inner parts of the chair.
- Do not use the castor if the floor is wooden or other easy damaged material.
- It may take 2 or more people to properly move the chair.
- Check to make sure that the power has been turned off, and that the plug does not touch the floor (It's better to let the chair in standing status to avoid the back crashing the floor)

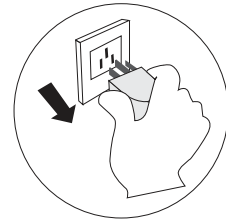

• How to Move

Lift up the legrest to make the gravity fall on the castor. Then push chair to destination and set it down.

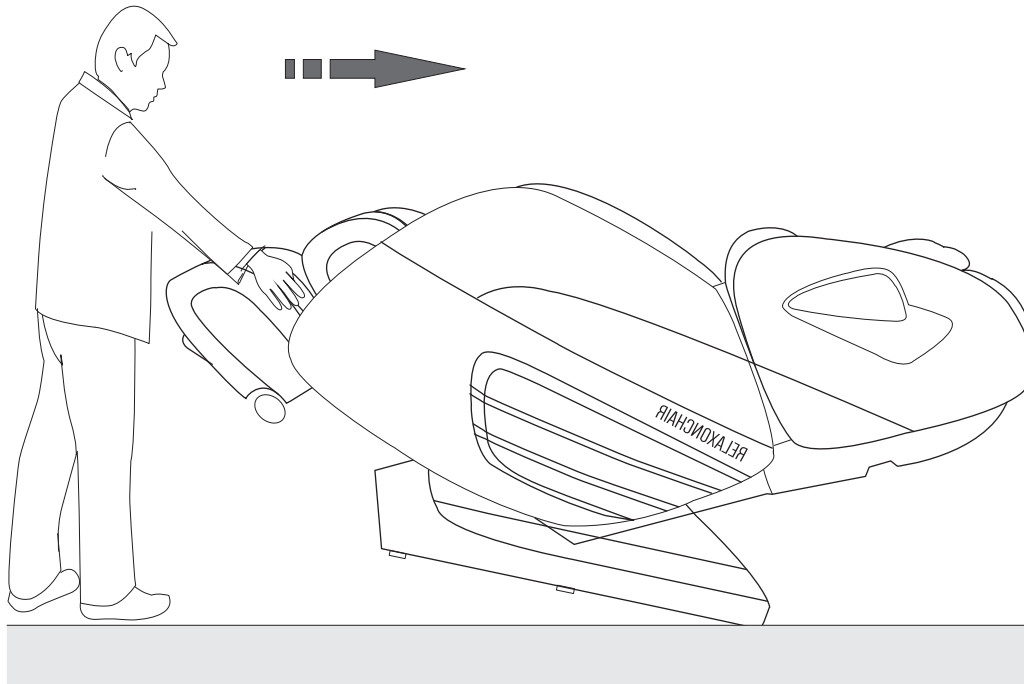

Please hold the footrest to move the chair as shown in the picture in case any scratches on the leatherette

15 ADJUSTMENTS BEFORE MASSAGING

MASSAGE ADJUSTMENT

• Massage Adjustment

- Make sure the massage head in right position before sitting on the chair.

* To avoid injure caused by wrong position of the massage head.

- Acupuncture point tracking detecting:

When doing acupuncture point position detecting, if massage machine can't detect the position, the actual shoulder height position was default to the middle part of the back.

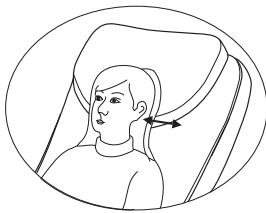
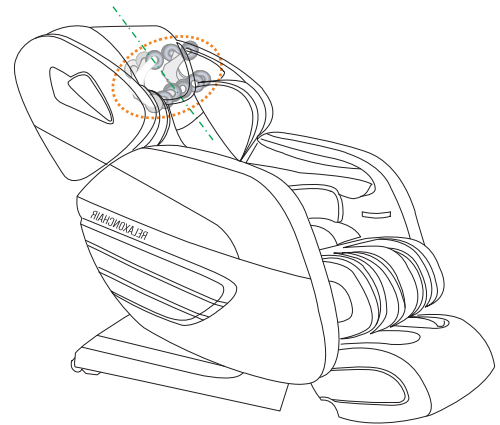

Right position:

Your back cling to the chair back, the head clings to the pillow.

The remote control gives “beep” sound after acupuncture point tracking detecting finished, when micro-adjustment is needed, just press up/down key on the remote control.

* Avoid for the massage head detecting your acupuncture point position not right, otherwise you won't get good massage.

• Kind suggestion





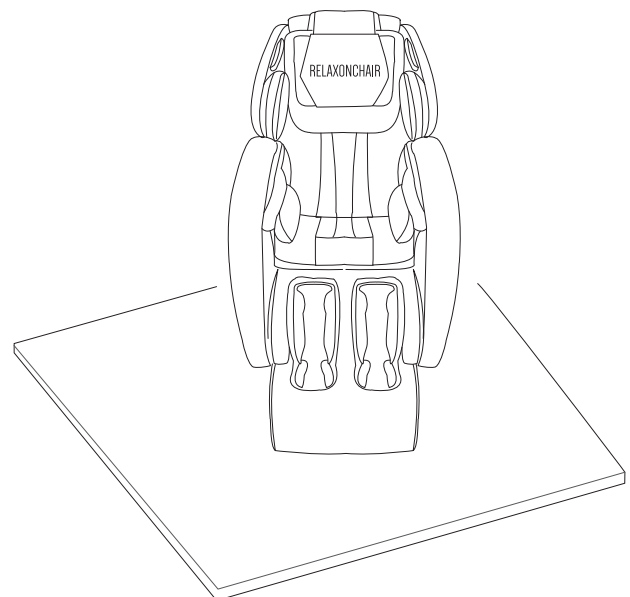
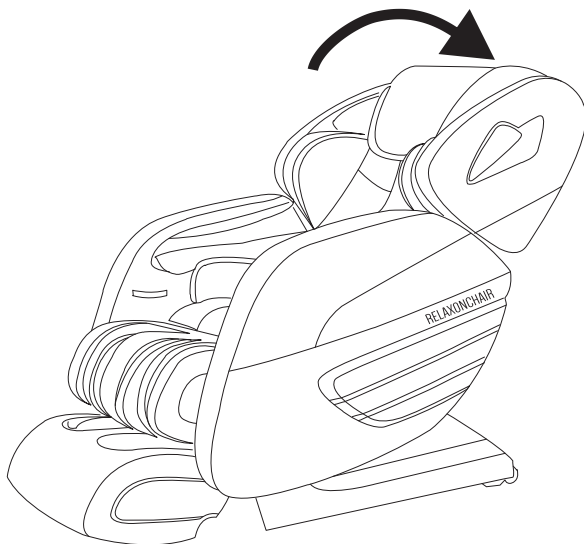

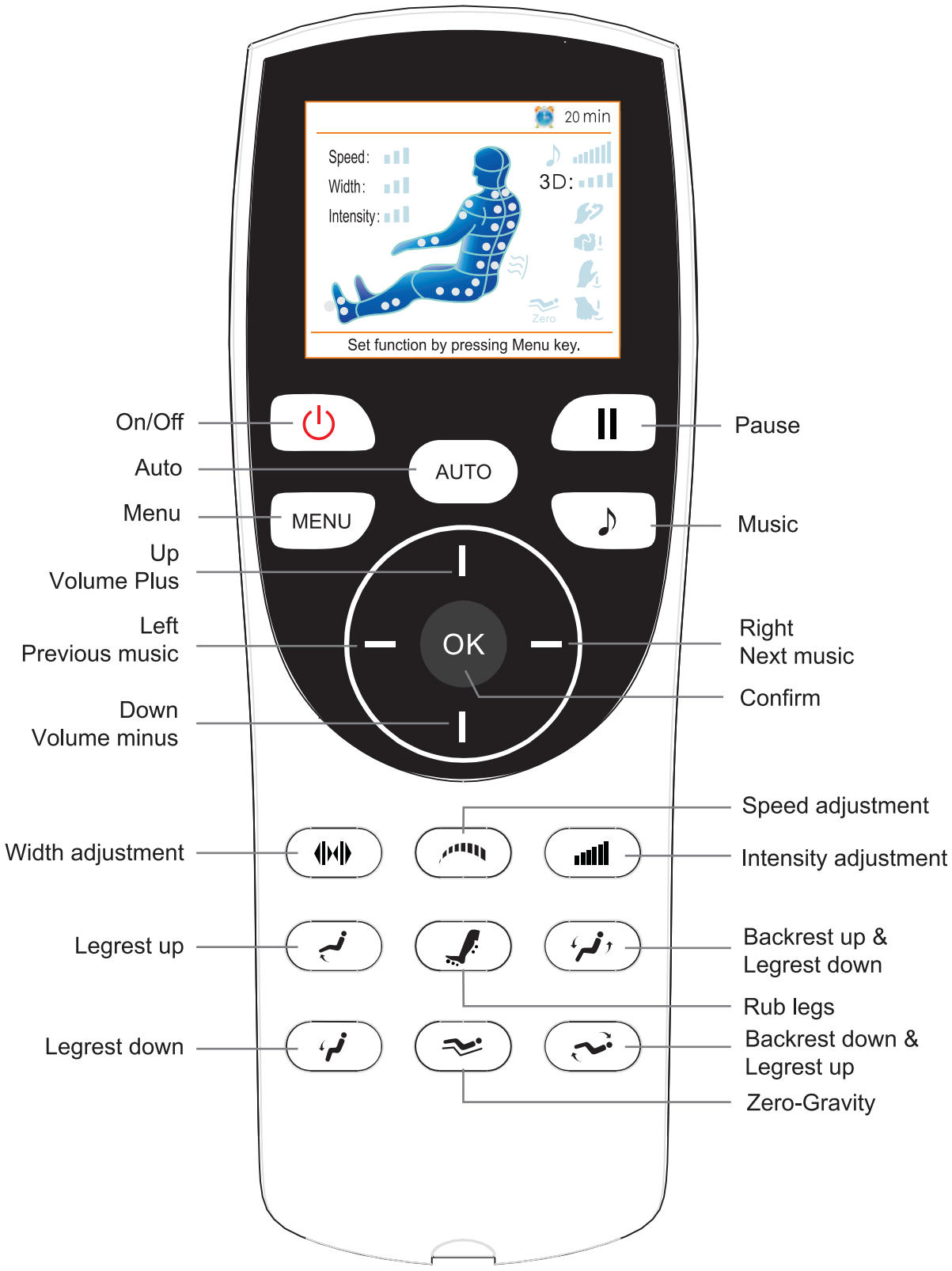





When you feel the intensity isn't strong enough, take off the pillow or cushion.

Because the chair is heavy, it may ruin your floor in long time setting. Please put a blanket or other soft things to protect your floor.





17 MANUAL CONTROL

	1. Press the on/off key to enter POWER ON status. Press Menu or other keys to select any auto or manual program. The massage chair will start the body scanning process, and then begin the massage. Press the on/off key to power off and put the chair back in the upright position. Remote control will turn off in 3 to 5 seconds.
	2. In the ON status, press this key to pause current massage, press it again to continue.
AUTO	3. In the ON status, press this key to switch different auto programs; Recovery, Pain Relief, Stretch, Music Sync, Experience and Stop. Relative screen display is shown on the controller.
Menu	4. Press this button to switch to menu interface where user can set different functions for massage.
	5. In the ON status, press this key to switch on or off music function.
	6. There are four direction buttons: Up, Down, Left and Right. In the menu interface, it is used as navigation key: press Up or Down to quickly browse the menu, and press Left and Right key to go to previous and next menu. In manual mode, the Up and Down key can also be used to adjust massage roller position in body scanning and fixed point massage. In music playing status, Left and Right key can switch previous and next song, Up and Down key can be used to set volume, press key twice to increase or reduce one grade volume.
OK	7. In ON status of menu mode, press this button to confirm selection.
	8. In ON status, press this button, it can adjust the massage width, wide-middle-narrow option for switching. The massage width can ONLY be adjusted in manual mode (Not available in kneading and knocking modes).
	9. In ON status, press this button, it can adjust the massage speed, 3 level options for switching. The massage speed only can be adjusted in manual mode (Not available in Shiatsu mode).
	10. In ON status, press this button, it can adjust air pressure intensity, 3 level options for switching. Air pressure intensity can be adjusted in auto mode or air pressure massage manual mode.
	11. Keep pressing this button, legrest goes up, release it, legrest stop moving. Controller screen will show position adjusting... when adjusting the position of massage chair.
	12. In ON status, press this button, it can adjust roller speed, fast-slow-turn off option for switching. Or turn on or off rub leg function, turn on-turn on- turn off option for switching.
	13. Keep pressing this button, backrest goes up, legrest goes down, release it, backrest and legrest stop moving. Controller screen will show position adjusting... when adjusting the position of massage chair.
	14. Keep pressing this button, legrest goes down, release it, legrest stop moving. Controller screen will show position adjusting... when adjusting the position of massage chair.
	15. In ON status, press this button, massage chair effect to zero gravity position, press this button again, massage chair return to original position, Zero gravity symbol in main interface will show the current zero gravity pose after start massage.
	16. Keep pressing this button, backrest go down, legrest go up, release this button, backrest and legrest stop moving. When adjusting sitting position, it shows seat position adjusting... in controller screen.

LCD DISPLAY GRAPHIC DESCRIPTION

- **Main Interface**

Press the On/Off key on your remote control to turn on the compact LCD display screen. You should hear the remote beep once to indicate power. Within 2 to 3 seconds, you should see the main interface. If you do not press a button shortly after powering up the device, it will go into standby mode. The main interface depicts information about your current massage session, including the chair's position, the type of massage, time, heating levels, music, and more. The information on the screen will automatically update every time you choose a new function or change your massage settings.

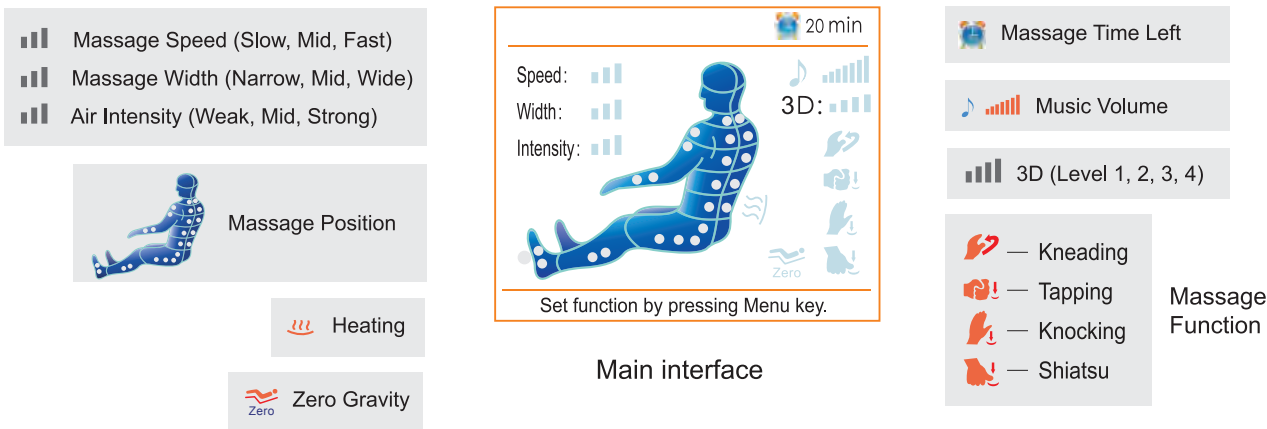

- **Menu Interface**

The MENU button will switch the remote display from the main interface to the menu interface. Pressing it again returns you to the main interface.

- **Auto Massage:**

The first setting available in the menu gives you access to 5 automated massage programs and a special massage setting containing 5 additional massages. Press OK, and then use the directional arrows to explore each massage session from the menu screen. Press OK again to initiate a session.

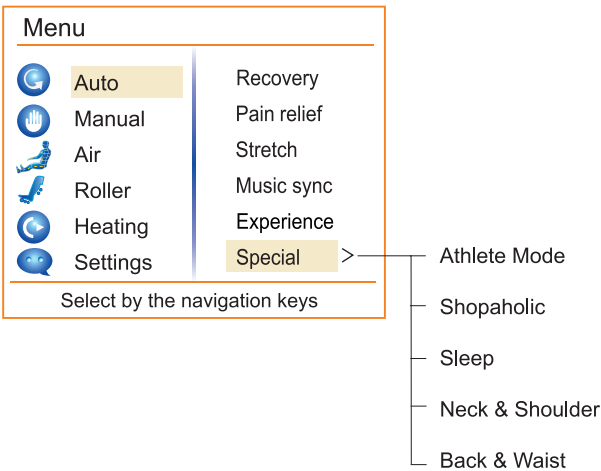

19 MANUAL CONTROL

Manual Massage:

On the main menu screen, navigate down to the “Manual” option. With this setting, you can adjust up to 5 aspects of your massage: the mode, width of massage rollers, position, speed, and 3D functionality. Choose the function of your choice, and navigate to the setting you would like to change. During a manual massage session, use the up and down directional buttons to adjust your massage position as needed.

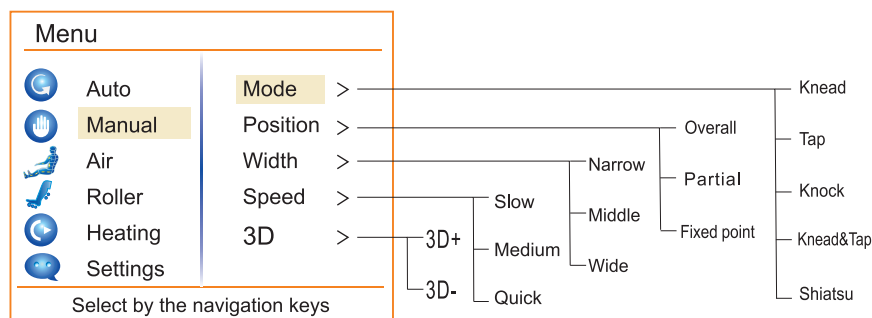

Air:

The third option in the menu controls the air flow on the massage chair. The air can be adjusted in two different ways: “Position” and “Intensity”. The “Position” option allows you to direct the airflow into the chair, giving the users the air options of “Overall” (Full Body), “Upper” (Shoulders), “Middle” (Arms & Waist), and “Lower” (Legs and Feet). The “Intensity” option allows users to change the amount of air pressure that the airbags exert. It gives three pressure options: “Weak”, “Medium”, and “Powerful”.

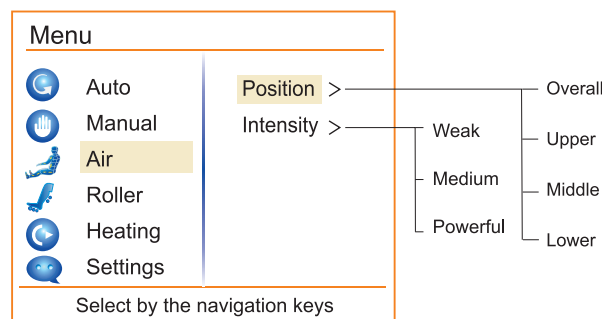

Roller:

This menu option allows the user to control the rollers on the legs and feet. From this screen, you can choose to have only the legs or feet rollers on while the massage is running using the “Leg” or “Feet” options. You also have the option of having both at the same time with the “All” option in the “Roller” menu option.

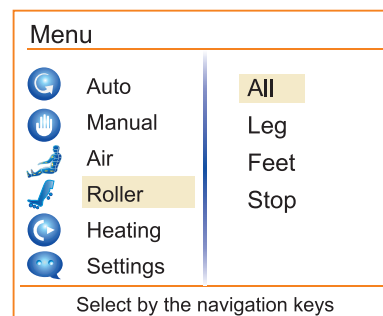

Note:

1. In all Auto programs, the foot rollers are defaulted to be ON. The rollers can be turned OFF with the “STOP” menu option under the “Roller” menu option.
2. During “Overall” and “Lower” air positions, the foot rollers are defaulted to be ON. The rollers can be turned OFF with the “STOP” menu option under the “Roller” menu option.
3. During “Upper” and “Middle” air positions, the foot rollers are defaulted to be OFF. The rollers can be turned ON with the “All”, “Leg”, and “Feet” menu options under the “Roller” menu option.

Heating:

This menu option allows the user to turn the heating function on and off. By pressing “Start”, the heating symbol will be displayed on the screen, and vice versa with “Stop”.

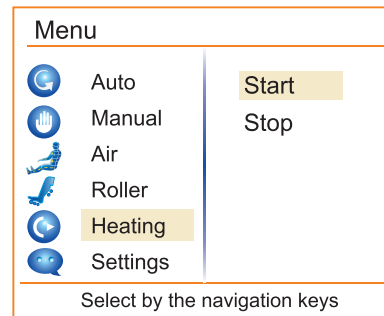

Setting:

Press the “Menu” button, choose “Setting”, then choose “Timer”, “Language” and “Stop” button.

Timer:

Select Timing to set the duration of your massage session. You have the option to set your massage for 10, 20, or 30 minutes. The chair’s default session duration is 20 minutes. When the massage time concludes, the chair will automatically turn off.

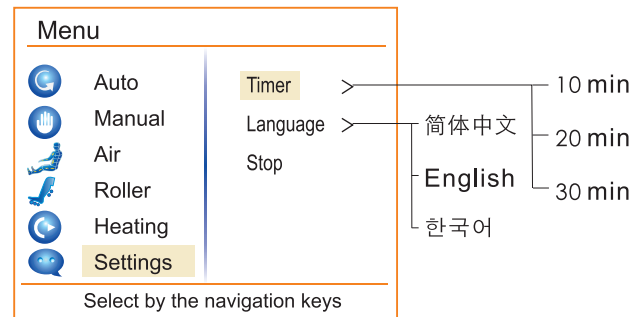

Language:

Choose the language of your choice from this screen (English, Chinese, and Korean)

Stop:

To stop your current massage and return to the main display screen, press this button.

* After Power is on, the first time to use auto program, massage chair will start acupuncture point position detecting, and “acupuncture point tracking...” will be shown on screen display. After acupuncture point detecting is finished, buzzer will tick 5 times (once every second), meanwhile, the massage machine is located in shoulders position, if user think the position is not proper, press Up and Down to adjust, when adjusting, “acupuncture point adjusting...” is showing on screen display. Default working time is 20 minutes. (Massage chair will turn off and return after the massage is over)

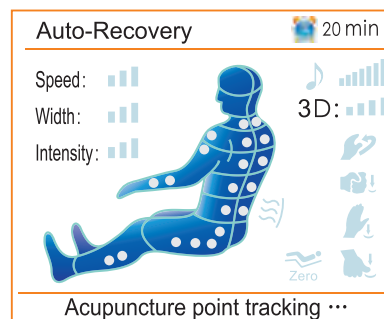

21 OPERATION INSTRUCTION

ON/OFF

• Step 1. Power On

1. Put one end plug of power line to hole 'a'.
2. Make sure controller wire connector insert to socket 'b'.
3. Put the power line plug insert to the socket.
4. Turn on the power switch which is on the power box.
5. Press "ON/OFF" button on the remote.

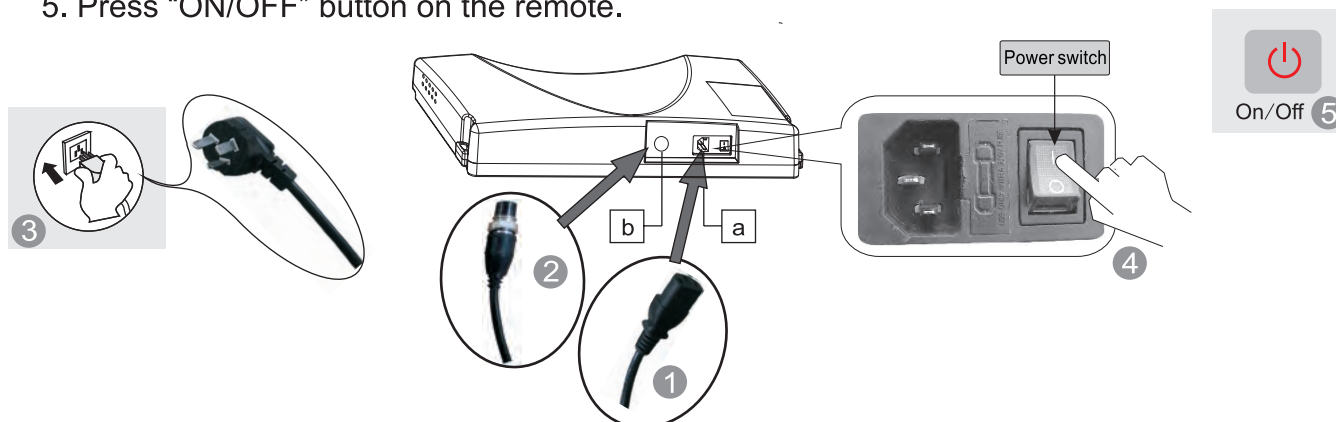

• Step 2. Massage

1. Operate according to the controller operation instructions.
2. When massage stop, massage machine return to the default position, meanwhile "Shutting down" displayed on the controller, controller off after 2-3 seconds.



• Step 3. Turn off the power

1. When the chair is On, Press ON/OFF button to return off the massage chair and it will restore automatically.
2. Turn off the power switch at the back of the chair after the rollers stay at storage position.
3. Unplug the power cable from the socket.

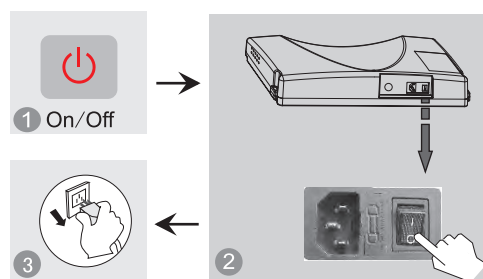

 Warning	<ol style="list-style-type: none"> 1. Before use, pull up the pillow, back cushion etc. to check if the PU material is broken, if there is damage, please stop using, unplug the chair, and ask for repairment. 2. Only plug to proper socket. 	 Attention	<ol style="list-style-type: none"> 1. Before sitting down, make sure there is no things pinched between armrest, legrest, backrest and seat of the chair. 2. Make sure the chair is in returned position before using. 3. Do not stand on the chair while using it.
--------------------	--	----------------------	--

• Legrest Up

Press and hold this button on the controller to lift up the legrest. Releasing the button stops moving the legrest, and locks the position of legrest.

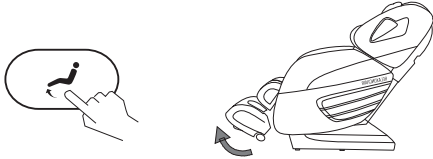

• Legrest Down

Press and hold this button on the controller to lower the legrest. Releasing the button stops moving the legrest, and locks the position of legrest.

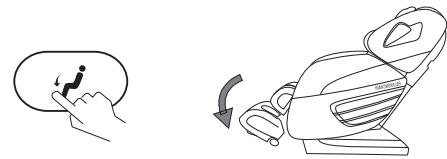

• Legrest Up & Backrest Down

Press and hold this button on the controller to lift the legrest and lower the backrest. Releasing the button stops moving the legrest and the backrest, and locks the position of the legrest and backrest.

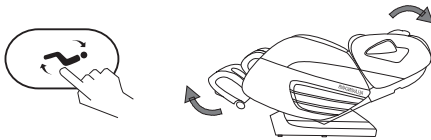

• Legrest Down & Backrest Up

Press and hold this button on the controller to lower the legrest and lift the backrest. Releasing the button stops moving the legrest and backrest, and locks the position of the legrest and backrest.

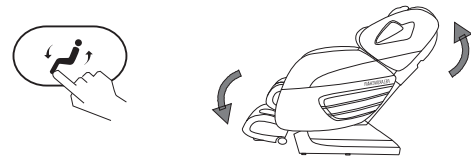

• Zero Gravity

Press the ZERO button on the remote control to adjust the position of the legrest and backrest into a zero gravity position automatically. Press the button again, the backrest and legrest stop moving, and it will lock at this position. However, to change the angles, we can keep comfortable massage status all the time.

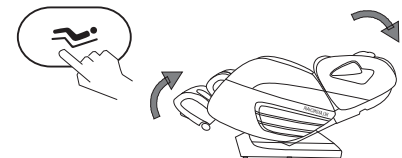

*Tips: Zero-gravity, according to the NASA space capsule relax theory, is to make the legs and heart be on the same elevation, which disperses the weight and pressure from the body and legs to the rest of the body, where each part is equally affected by the effects of gravity. This achieves a comfortable, relaxing massage posture.

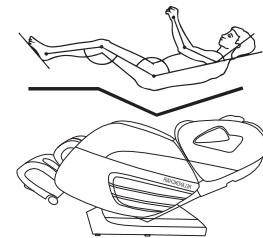

Warning

1. Please make sure that there is nothing within the vicinity of the chair that can be damaged or injured.
2. When adjusting the chair, be careful of the gap between the armrest and the seat of the chair.
3. While the legrest is moving, please do not stand or put pressure on the legrest, nor should you leave from the seat until it has completely stopped in order to prevent causing damage to the internal mechanisms of the chair.
4. Please Refer to the control instructions for more details.

23 FUNCTION ILLUSTRATION

- Extending and Retracting the Legrest

The legrest can extend and retract within a range of 7 inches.

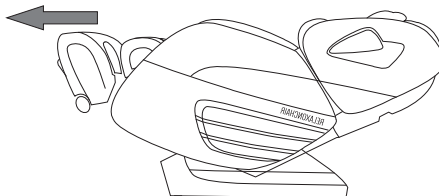

- Arm Massage

Put the arms in between the armrest's airbags before the embedded airbags filled with air. It will perform pinch massage techniques to arms and hands after airbags inflating.

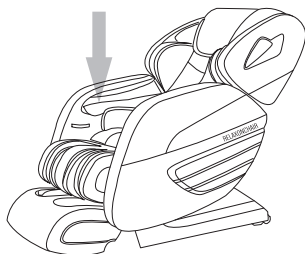

- Shoulder Massage

Multi-layered extrusion airbags is deployed on both sides of the shoulder. Achieve pressure shoulder stretch massage, relieve shoulder fatigue.

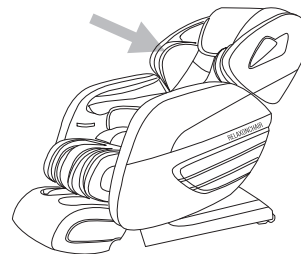

- Rubbing Leg

Legrest has the function of rubbing leg and press massage with multiple-layers of airbags. It adopts rubbing and pulse pressure on the legs muscles to promote blood circulation, recover the vigor of legs.

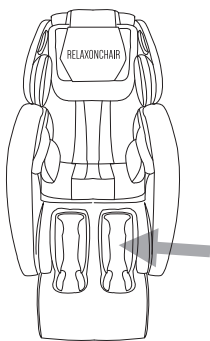

- Foot Roller Massage

Footrest parts with roller massage and air pressure massage function. Through stimulating the foot reflex zones, and clear the body meridians, regulate and restore human organs function, improve the body resistance and immunity effectively.

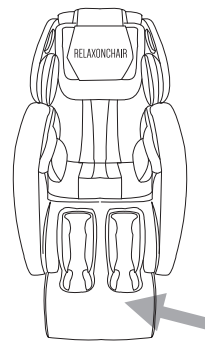

RESTORATION OF MASSAGE CHAIR

1. Make sure there is no people, pet or anything within range of backrest and legrest.

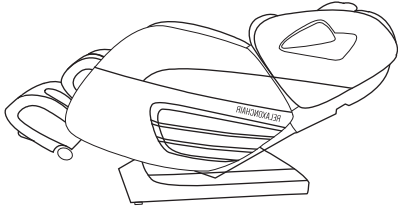

3. After the chair returns to the upright position, put the remote control back into the remote control pocket on the right armrest.

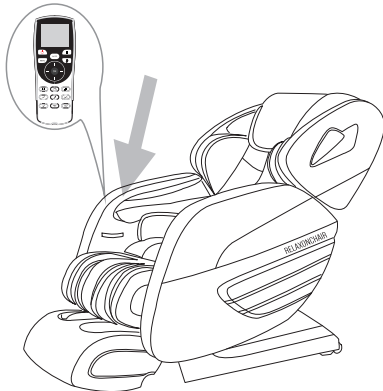

5. Unplug the power cable from the electrical socket by tugging on the base of the plug and not the cable.

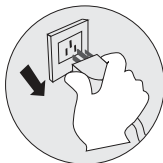

2. The backrest and legrest can be restored to the upright position by pressing the ON/OFF button on the chair to turn off the power.

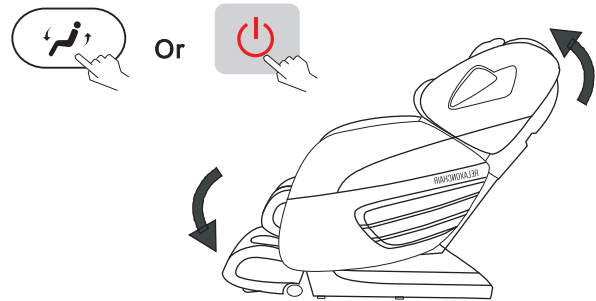

4. Switch of the power switch located at the back of the base of the chair.

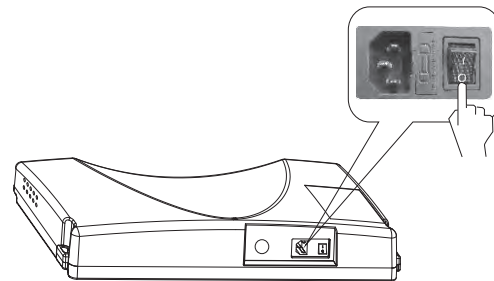

6. Clean the chair if necessary.

 Attention	<ul style="list-style-type: none"> • After using, press the ON/OFF button to end all operations on the chair, and please wait for the chair to fully stop moving before getting out of the chair. • Make sure to unplug the electricity. Avoid moisture, dirt, etc. in case of causing damage.
---	--

25 CLEAN & MAINTENANCE

SYNTHETIC LEATHER

- **General Cleaning**

Clean with tidy, soft, and dry cloth slightly.

Note: Do not use thinner, gasoline, alcohol or other chemicals.

- **If the leather is dirty**

1. Dip the soft cloth into a 3-5% neutral detergent solution, wring out most of the liquid, then clean the stain on the surface very gently.
2. Wash the cloth, squeeze it out, then wipe with just water.
3. Clean the area with a soft dry cloth.
4. Allow for the area to dry naturally.

CLOTH MATERIAL

1. Dip cloth into weak neutral detergent, squeeze out most of the liquid, and gently wipe down the area.

Note: Do not use thinner, gasoline, alcohol, or other chemicals.

2. Brush down the area with a weak neutral detergent.

Note: excessive cleaning may cause damage to the material.

3. Wipe with water-dipped but squeezed cloth.
4. Allow to dry naturally.

PLASTIC PARTS

1. Dip cloth into weak neutral detergent, squeeze out most of the liquid, and wipe the area.
2. Dip cloth into water, squeeze out most of the liquid, and wipe down the area.
3. Allow to dry naturally.

CLEAN THE CONTROLLER

1. Wipe with soft wet cloth that has most of its liquid squeezed out.
2. Allow to dry

ABOUT CLEANING

Before cleaning, unplug the electricity. Do not unplug something electrical with wet hands. Make sure that your hands are dry when plugging the chair back into the socket.

Note: Failure to follow the cleaning instructions may get you shocked or burned.

FAQ AND TROUBLESHOOTING

Trouble	Possible reason	Troubleshooting
The massage chair can't work after power is on.	Check if the control is on or not.	Open control switch
	Not choose massage function	Choose massage function
	Check whether the plug and socket in poor contact.	Make sure plug and socket are connected.
	Wire or plug has damaged.	Please ask manufacturer or appointed or authorized maintenance man for checking and replacement.
	The fuse burned out.	Replace fuse of same specification.
	Something wrong with inner circuit	Please ask appointed or authorized maintenance man for checking and repairing.
There is beep sound inside the massager while working.	It is sound of air pump, motor and mechanical parts.	Normal sound, no need to pay attention to it.
Different height of the left roller and right roller.	Massage rollers work on shifts.	Normal, no need to pay attention to it.
Sound suddenly becomes much louder while working.	Check if it is due to long time working.	Turn off the power to have the massager rest for over half an hour before next turn working.
	Inner parts fretted away due to long time work. It's normal	Please ask appointed or authorized maintenance man for checking and repairing.
Massage function suddenly stops while working.	Suddenly power-down	Connect the electricity power again
	Setting time is up.	Turn off the power to have the massager rest for over half an hour before next turn working.
Neither the backrest nor the legrest can be lay down.	Check if there are any obstacles; the chair overloads; for the sake of safety, sometimes the massage machine may automatically stop working.	Remove the obstacles; turn off the power to have the massager rest for over half an hour before next turn working.
The chair can't return to its original position.	Excessive operation; setting time is up.	Please ask manufacturer or appointed or authorized maintenance man for checking and replacement.
Electric wire or plug give out heat	It may work overload	Turn off the power to have the massager rest for over half an hour before next round working.
	Other abnormal case	Stop using, and ask appointed maintenance man for help.



Note: If the troubles are not caused by above reasons, please turn off the power switch and cut off the power, then contact the manufacturer or service agent to repair your chair.

27 TECHNICAL DATA

TECHNICAL DATA

Name	Massage Chair	Power	200W
Model	ION - 3D	NW/GW	Main body: 179/238 lbs Armrest: 28.6/39.6 lbs Legrest & footrest: 47/53 lbs
Input voltage	□ AC120V, 60Hz		Packing size
Safety design	Class I		