

RELAXONCHAIR®

BEST ZERO GRAVITY SHIATSU FULL BODY MASSAGE CHAIR

RIO USER MANUAL

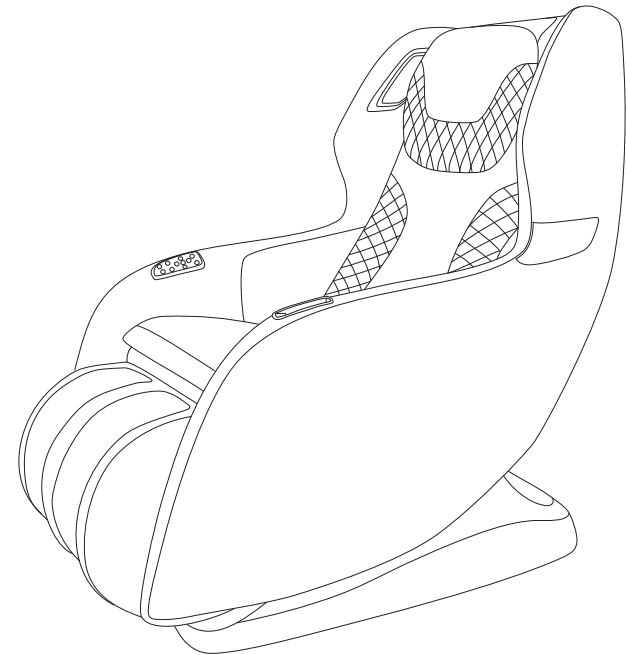

www.relaxonchair.com Tel. (866) 647-3496
Developed in USA / Manufactured In China

Please read SAFETY INSTRUCTIONS carefully before using the chair.

CONTENT

Please read and follow all safety and operating instructions listed in this user manual before use. Basic precautions should always be used when operating.

Safety Instructions	-----2-3
Product Specifications	-----4
Product Components	-----5-6
Chair Installation	-----7-8
Remote Controller	-----9
Operation Guide	-----10-12
Trouble Shooting	-----13
Maintenance	-----14

Note: The Company reserves the right to revise the design and description of this product without any further notice.

MAINTENANCE

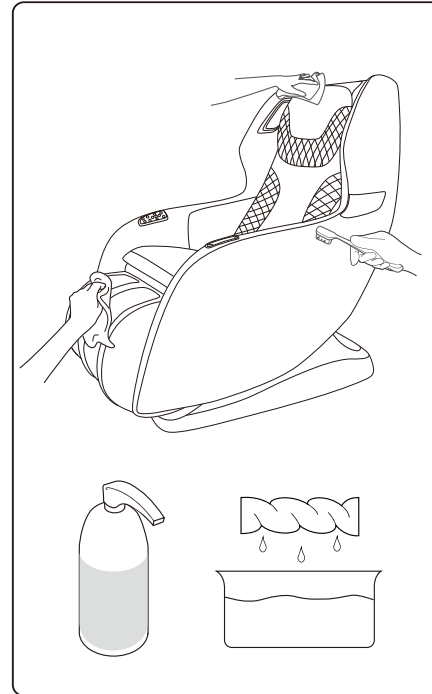

- Turn OFF and pull out the power plug before clean the massage chair, do not touch the power plug with wet hands.

- Please use neutral wash to wipe and lightly brush the chair.

- Use dry cloth to wipe and sweat and other besmirch.

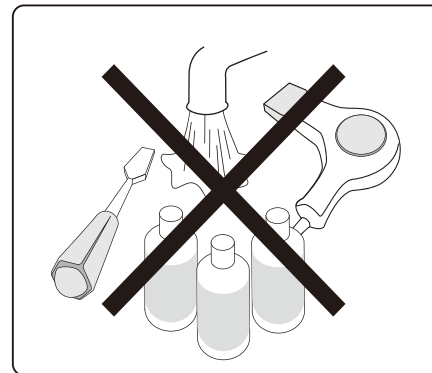

- Do not use water to clean the chair.

- Do not use a hairdryer to dry the massage chair.

- Do not use gasoline, thinner, alkaline lotions, bleach, etc

TROUBLE SHOOTING

If the sounds or movements are not normal, please turn off the massage chair and remove the plug from the electric outlet. Please contact the customer service department for further assistance.

Problem	Solution
Makes a sound when operating.	The sound of the structural design will not affect the chair.
The massage chair is connected to power but is not functioning.	1. Check to see if the power plug is inserted properly or if the power outlet is functioning properly. 2. Check to see if the main power switch is in the "I" position.
The remote controller is responding, but the massage chair is not functioning.	The massage chair may have automatically shut down due to overheating protection devices. Please turn off the power and allow the chair to cool off for 30-50 minutes.
Both the remote controller and massage chair are not responding.	The massage chair automatically turns into "full stop" or into "idle" mode when a massage program is completed. Please press the power button again to turn on the chair.

SAFETY INSTRUCTIONS

Warning

The power plug must insert properly to the power outlet. If the connection of power plug is not connected properly it can result the risk of electric shock. Do not modify the power plug provided with the product, if the outlet is not suitable. Please make sure that the power outlet is properly installed by a qualified electrician. When using the massage chair, basic precautions should always be followed to reduce the risk of electric shock.

1. Please make sure that the power plug is inserted into the proper outlet to reduce the risk of short-circuit and fire.
2. Always unplug the massage chair from the electrical outlet immediately after use and before cleaning.
3. Do not use the massage chair in places where the humidity is high.
4. Do not use the massage chair for outdoors and avoid place with direct sunlight.
5. If the power goes OFF during use make sure to switch the power OFF position and removed the power plug from power socket to prevent damage when the power is restored.
6. Do not operate the massage chair if the power cord is wet or damaged.
7. Do not plug or unplug the power cord from the power socket with wet hands.
8. Supervision is necessary when the massage chair is being used by or near the children or disabled person.
9. Use the massage chair only for its intended use as described in this user manual.
10. Do not stand, sit or jump in the calves rest, backrest and armrest when the massage chair is in use to prevent any injury.
11. Do not fall asleep during the massage session.
12. Always keep the massage chair clean and do not insert any object into the gaps and around the massage chair.
13. Do not move the massage chair by pulling the power supply cord.
14. Make sure that when lowering the lower leg, there are no other objects, especially children.
15. Always check whether the surface of the massage chair is torn or ripped before usage, if you found any unfamiliar rips in any area of the cloth in the backrest, do not use the massage chair. Kindly contact the authorize service center for repair.
16. This appliance is designed for household use only.
17. For those people who suffering from illness, please consult doctor before use.

SAFETY INSTRUCTIONS

18. The following conditions should consult doctors before use:
- Suffering from malignant tumor.
 - People with heart disease.
 - Women in pregnancy, menstruation and perpetual fever.
 - People who are medicated or under medication.
 - People with osteoporosis.
 - People with back bended exceptionally by the accident or disease.
19. If you experience pain during usage, stop using the massage chair immediately. If any injuries occur, seek medical treatment immediately.
20. Do not massage the swollen or inflamed parts of the body.
21. This product is non-professional appliance designed to provide a comfortable massage. Do not use this product as substitute for medical treatment.
22. Each massage session should not exceed 30 minutes. Massage the targeted area for only 15 minutes, over massaging can lead to overheating, thus giving the appliance shorter lifespan.
23. Do not operate where aerosol (spray) products are used or where oxygen is being administered.
24. The massage chair is not suitable for children aged 12 and below.

NOTE:

- This appliance is not intended for use by persons (including children) to reduce the physical sensory or mental capabilities or lack of knowledge how to use the massage chair, unless they have been given supervision or instruction concerning to use this appliance by the responsible person for their safety.
- If the power supply cord is damaged it must be replaced by a special or assembled available from the manufacture or its service agent.
- The massage chair heats up during operation, persons sensitive to heat must take extra caution when using the massage chair.
- The maximum load of this product is 250lbs exceeding of its will affect the performance of the product.

OPERATION GUIDE

After use

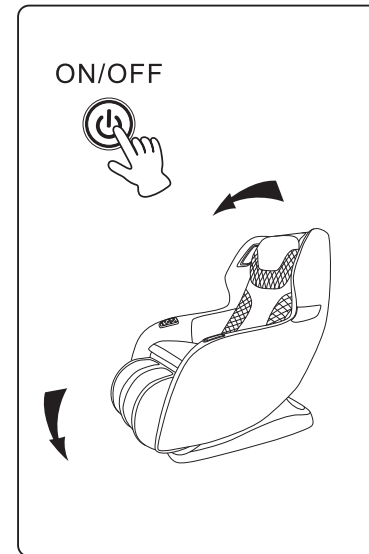

- 1) Press the power button to power off the massage chair.

*Make sure whether there are no barriers around the massage chair.

- 2) Get up when massage chair rest to initial state

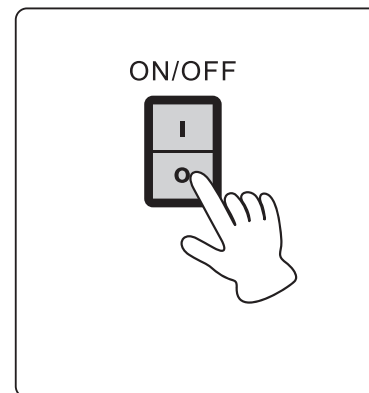

- 3) Turn off the main power switch.

- 4) Remove plug from power outlet.

- * Please do not pull on the power cord to remove the plug.
- * Please do not unplug with wet hands.

OPERATION GUIDE



Press the button to rise the backrest.



Press the button to recline the backrest.



Press to start/stop the spot massage.

The method of playing the bluetooth music in massage chair

A.Match:Open the bluetooth function in mobile phone or Ipad, and search nearby. Choose the massage chair bluetooth music equipment and match with it.

B.Play music:After matching with it,you can display the music by mobile or App music display software.

Attention:

Please off the bluetooth connection when not in use so as for other devices to connect smoothly.

PRODUCT SPECIFICATIONS

Description	Specifications
Product Name	RC-RIO
Model No.	
Rated Voltage	100 V~ 240V
Rated Frequency	50/60Hz
Rated Power Consumption	65W
Carton Dimension	45in(L)X30in(W)X46in(H)
Weight	Net Weight: 123Lbs Gross Weight: 143Lbs

Main Body Diagram(Front)

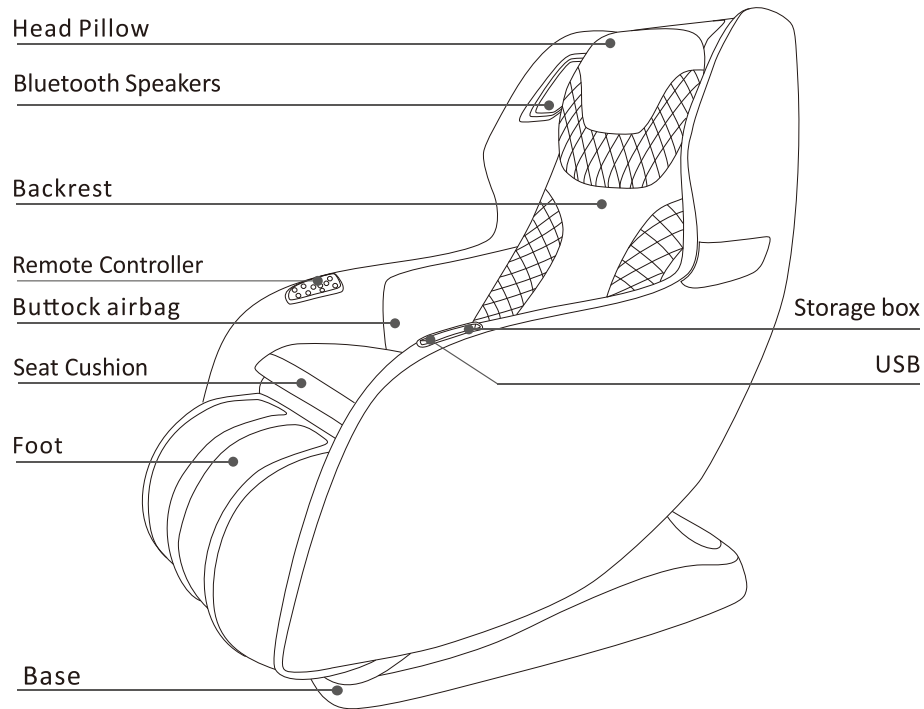

The legrest can turnover and hide as following:

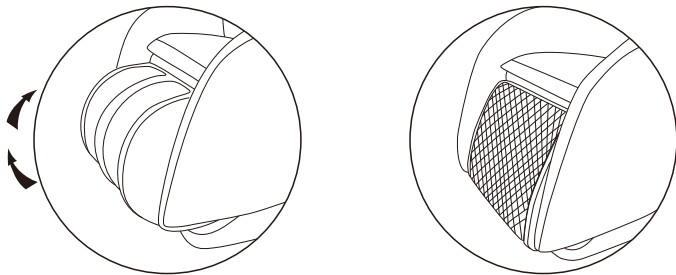

Function Description of Controller Buttons



Press once to turn the massage chair on.



This chair design with 8 sets of auto massage program for different time and people to use.
When you use it continuously . Please have 10 minutes of rest in order not to add burden to the body.



Press to change manual mode
Kneading – Tapping – Kneading&Tapping – Shiatsu – Rolling – Clapping – Off



Long press to adjust the position of massaging ball.



Switch on/off for heating function.



Press to adjust the strength of massage, with 2 intensity levels to select from.



Press to adjust intensity of air massage, with 2 intensity levels to select from.

REMOTE CONTROLLER

Remote Controller

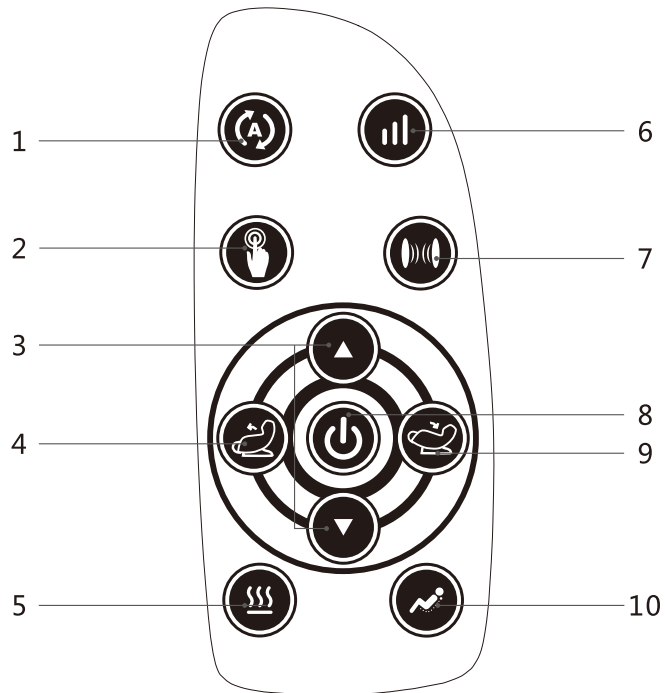

- | | | |
|-------------------------|-----------------|-------------------|
| 1.Auto Mode | 2.Manual Mode | 3.Position Adjust |
| 4.Recline Up | 5.Heat | 6.Strength Adjust |
| 7.Air Massage Intensity | 8.On/OFF Button | 9.Recline Down |
| 10.Spot Massage | | |

PRODUCT COMPONENTS

Main Body Diagram(Rear)

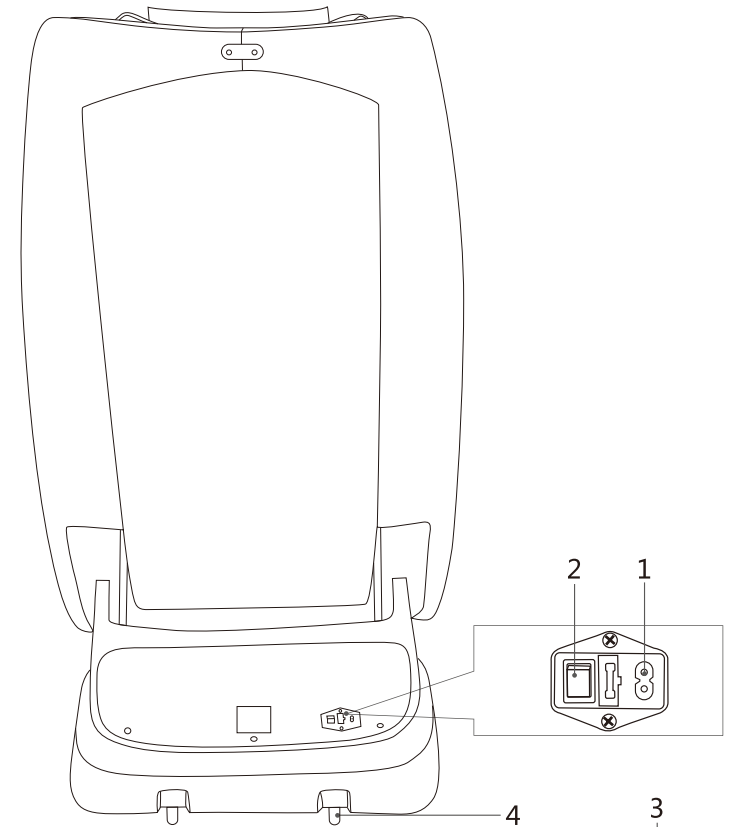

- | |
|----------------------|
| 1. Power Cord Socket |
| 2. Main Power Switch |
| 3. Power Cord |
| 4. Wheels |

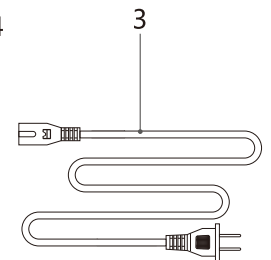

CHAIR INSTALLATION

1. Remove the package and get out the spare parts

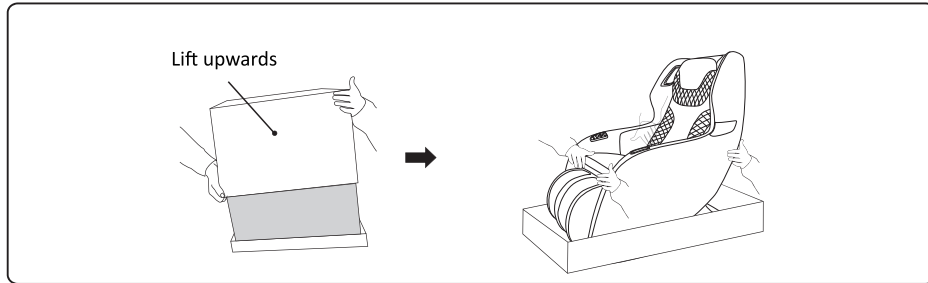

- 1) Remove the carton; Take out the package.
- 2) Install the pillow, backrest cushion, cushion and spare parts.

2. Place the massage chair in an open area

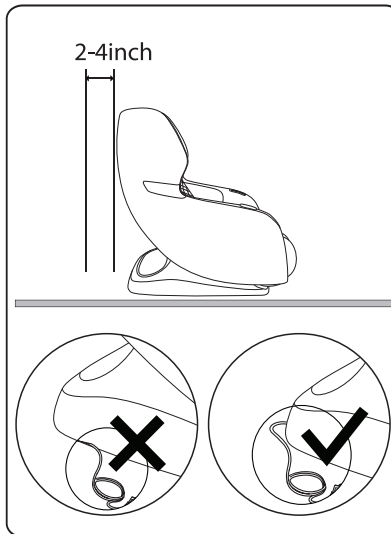

- Lift the entire massage chair out of the bottom box and place it in a suitable place in your home.

- Allow sufficient space around the chair for recline purposes.
5-10cm distance for the back side and 40cm in front of the footrest.

***In order to avoid the damage of the floor and to reduce the noise, please put area rug under the massage chair.**

***Make sure that there are no barriers in front and the back of the massage chair.**

***Please do not put it in wet or uneven floor.**

***To avoid signal interference, please place it 4 feet away from AV,TV, and radio.**

Warning:
Do not put the power cord under of relax chair!

3. Double check the installation steps, smooth out any creases in the cushions.

CHAIR INSTALLATION

4. Moving the massage chair.

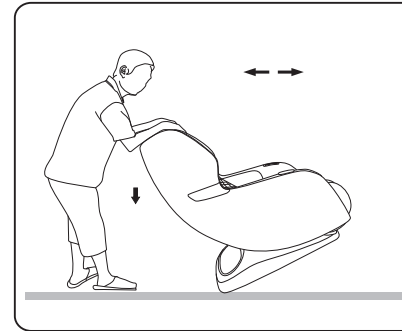

As illustrated, push the backrest downwards and tilt chair on to its wheels at a 45° angle. Slowly push and maneuver the massage chair to desired location. Lower massage chair slowly and smoothly until it is fully flat on the ground.

CAUTION:

- *Do not move massage chair when occupied or in use.
- *Moving the massage chair may cause damage to the floors. Floor protection is recommended (e.g. rugs or carpet).
- *Do not drop or suddenly let go of the chair when moving as it may damage the chair.
- *Two persons are recommended when moving and extra care when handling the massage chair.