

SWING-AWAY AUGER

Meridian is committed to manufacturing the highest quality products and that's why our Swing Away Augers are durable, steadfast and reliable.

At Meridian, we want to help our customers get their work done faster, safer and more efficiently. Our products are designed with the features that farmers need and constructed using high-quality parts and industry-leading manufacturing techniques, meaning that our augers keep performing, season after season.



APPLICATIONS

- Load and unload Bins / Silos
- Load Trucks and Trailers

10 INCH TUBE

Model	Under-Carriage	Tube Dia.	Capacity	Height A		Length C		Length D		Length E	PTO
				Raised	Lowered	Raised	Lowered	Raised	Lowered		
SLMD10-65	Scissor Lift	10"	180 tonne per hr	39'3" (11.88m)	9'4" (2.74m)	30'2" (9.14m)	38'4" (11.58m)	23'5" (7.1m)	27'2" (8.22m)	65' (19.8m)	✓
SLMD10-72	Scissor Lift	10"	180 tonne per hr	46'1" (14m)	12'2" (3.7m)	30'4" (9.3m)	36'6" (11.1m)	26'3" (8m)	33' (10.1m)	72'2" (22m)	✓
SLMD10-75	Scissor Lift	10"	180 tonne per hr	45' (13.71m)	10'7" (3.04m)	30'2" (9.14m)	38'4" (11.58m)	31'7" (9.44m)	37'1" (11.27m)	75' (22.8m)	✓
SLMD10-85	Scissor Lift	10"	180 tonne per hr	50'9" (15.24m)	11'10" (3.55m)	30'2" (9.14m)	38'4" (11.58m)	39'7" (11.88m)	47' (14.32m)	85' (25.9m)	✓

12 INCH TUBE

Model	Under-Carriage	Tube Dia.	Capacity	Height A		Length C		Length D		Length E	PTO
				Raised	Lowered	Raised	Lowered	Raised	Lowered		
SLMD12-72	Scissor Lift	12"	240 tonne per hr	45'6" (13.9m)	10'9" (3.3m)	30'6" (9.3m)	39'9" (12.1m)	25'8" (7.8m)	31'5" (9.6m)	72'6" (22.1m)	✓
SLMD12-79	Scissor Lift	12"	240 tonne per hr	49'6" (15.1m)	10'9" (3.3m)	33'2" (10.1m)	43'1" (13.1m)	28'3" (8.6m)	34'9" (10.6m)	79' (24m)	✓
SLMD12-85	Scissor Lift	12"	240 tonne per hr	53'7" (16.3m)	10'9" (3.3m)	35'9" (10.9m)	46'5" (14.2m)	30'10" (9.4m)	38' (11.6m)	85'7" (26.1m)	✓
SLMD12-95	Scissor Lift	12"	240 tonne per hr	57'1" (17.4m)	14'6" (4.4m)	35'9" (10.9m)	46'5" (14.2m)	40'10" (12.5m)	52' (15.9m)	95'7" (29.1m)	✓

13 INCH TUBE

Model	Under-Carriage	Tube Dia.	Capacity	Height A		Length C		Length D		Length E	PTO
				Raised	Lowered	Raised	Lowered	Raised	Lowered		
SLMD13-75	Scissor Lift	13"	350 tonne per hr	44'4" (13.5m)	10'11" (3.1m)	32'3" (9.8m)	40' (12.2m)	30'6" (9.3m)	36' (11m)	75' (22.8m)	✓
SLMD13-85	Scissor Lift	13"	350 tonne per hr	49'7" (15.1m)	11'6" (3.5m)	32'3" (9.8m)	40' (12.2m)	39'5" (12m)	45'11" (14m)	85' (25.9m)	✓
SLMD13-95	Scissor Lift	13"	350 tonne per hr	59'4" (18.1m)	10'5" (3.2m)	39'5" (12m)	49'11" (15.2m)	37' (11.2m)	45'8" (13.1m)	95' (28.9m)	✓
SLMD13-115	Scissor Lift	13"	350 tonne per hr	71'7" (21.8m)	14'11" (4.5m)	39'5" (12m)	49'11" (15.2m)	52'10" (16.1m)	65'6" (20m)	115' (35m)	✓

14 INCH TUBE

Model	Under-Carriage	Tube Dia.	Capacity	Height A		Length B		Length C		Length D		Tube Length E	Swing Length F	G		PTO
				Raised	Lowered	Raised	Lowered	Raised	Lowered	Raised	Lowered			Operation Width	Transport Width	
SLMD14-95	Scissor Lift	14"	395 tonne per hr	69'3" (21.1m)	9'4" (2.85m)	36'2" (11.02m)	5'3" (1.6m)	37' (11.28m)	46' (14.02m)	29'8" (9.04m)	46'7" (14.2m)	95' (29m)	20'5" (6.22m)	13' (3.96m)	13' (3.96m)	✓
SLMD14-105	Scissor Lift	14"	395 tonne per hr	76'4" (23.27m)	10'3" (3.12m)	36'2" (11.02m)	5'3" (1.6m)	37' (11.28m)	46' (14.02m)	36'9" (11.2m)	56'8" (17.27m)	105' (32m)	20'5" (6.22m)	13' (3.96m)	13' (3.96m)	✓
SLMD14-115	Scissor Lift	14"	395 tonne per hr	83'3" (25.37m)	12'1" (3.68m)	36'5" (11.1m)	5'11" (1.8m)	37' (11.28m)	46'5" (14.15m)	42'10" (13.06m)	66'2" (20.17m)	115' (35.05m)	20'5" (6.22m)	NA	14'3" (4.34m)	✓

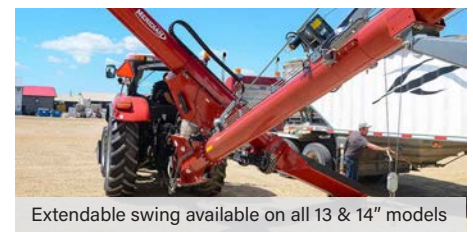
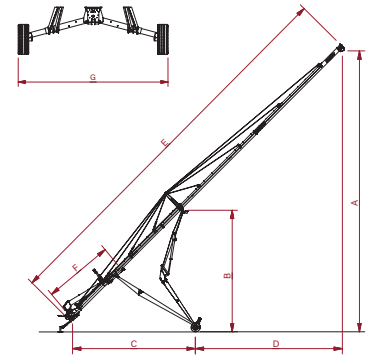

Extendable swing available on all 13 & 14" models

FEATURES

- 1 Year Parts and labour warranty (all tube options)
- Auger flight reverse system (all tube options)
- Head end blowout doors (13" and 14")
- 540 RPM PTO system (all tube options)
- Self levelling, low profile hopper system (all tube options)
- Break winch to raise and lower auger (all tube options)
- Powder coated finish (all tube options)
- Hydraulic worm-winch for swing (all tube options)
- 12V Kramble remote control swing hopper mover (14" only)

OPTIONAL FEATURES

- Light system
- Electric hopper mover
- Hydraulic hopper lift
- 1000 RPM reducing gearbox
- 12V Kramble remote control swing hopper mover (10", 12" and 13")