



ORDER #: \_\_\_\_\_

S/N: \_\_\_\_\_

(Required for Warranty)

# KOHILO 2.8

## WHOLE HOUSE FAN

### INSTALLATION AND OPERATION MANUAL



Thank you for purchasing a Kohilo® whole house fan. This fan has been designed to provide many years of natural, quiet, and energy-efficient cooling.

Please take a few minutes to read over this manual and its accompanying documents to make sure you are prepared to install the fan. In particular:

- The homeowner/resident should read the WHERE TO LOCATE section so that the fan will be correctly located to maximize its effectiveness and efficiency.
- The VENTILATION REQUIREMENTS section is also particularly important, as it describes the minimum attic ventilation necessary to operate the fan.
- The INSTALLATION: BACKDRAFT DAMPER section contains important information regarding the constraints within which this fan's backdraft damper must be installed.

Before installing this fan, inspect it and all of its parts for any damage it may have sustained during shipping. **DO NOT INSTALL DAMAGED EQUIPMENT.** If you suspect this fan has been damaged during shipping, contact AirScape technical support by phone at 1.866.448.4187, or email at [experts@airscape-fans.com](mailto:experts@airscape-fans.com).

Whole House Fans are designed to be installed within a home's attic, which makes them and their sub-components extremely difficult to access once installed. **TEST THIS FAN OUTSIDE OF THE ATTIC BEFORE INSTALLING IT PERMANENTLY.**

## SAFETY INFORMATION



Some of the principles of this product's safe installation and operation are not immediately obvious. Read the following safety information before continuing further:



- **Never** operate this fan without a window or door opened
- This fan is meant for general ventilation. ***It has NOT been designed to ventilate particle laden and/or explosive mixtures of air and must NOT be used for such.***
- This fan is NOT for use in kitchens
- Before installing or servicing this fan, switch power off at the home's electrical panel to reduce the risk of damaging circuit boards, fire, electrical shock, or injury.
- Install this fan in accordance with this manual and all local codes and standards.

## BACKDRAFT DAMPER INFORMATION



The gravity backdraft damper provided with this Kohilo 2.8 unit does not provide an airtight seal or insulated barrier between the living space and attic. It is the homeowner's responsibility to ensure the unit is sealed and/or insulated during the winter.



This damper also requires additional assembly. Assembly instructions for the backdraft provided in the supplementary Backdraft Damper Assembly Instructions included with this fan.

## SUPPLIES INCLUDED IN THE BOX

Prior to beginning installation, please verify all of the following items were received with the fan:

- Fan assembly
- Chain (25 ft.)
- 2-inch Duct tape (25 ft.)
- 3-inch Duct tape (30 ft.)
- 7 ft. of acoustic flex duct (20" diameter)
- Backdraft damper kit, including: damper body parts; 58 ¼" damper screws; and, 4 damper mounting brackets
- White cube core grille & White phillips head screws (8)
- Wood screws (8)
- Self-tapping sheet metal screws (4)
- S-Hooks (4)

## REQUIRED TOOLS & SUPPLIES NOT INCLUDED

In addition to the included items listed above, the following tools and supplies are required to install the fan but have NOT been included:

- **Wall switch or timer, with electrical box and hardware for mounting**
- **Residential 115V wiring (Romex 14/3 is used most commonly)**
- Phillips head screw driver
- Scissors or Knife
- Pliers
- Drywall Cutter
- Cordless screwdriver with Phillips head and miscellaneous drill bits
- High quality latex caulk
- Lumber matching dimensions of the attic joists (e.g. 2"x6", 2"x8", etc.) and cut to fit according to the **INSTALLATION: FRAMING** section.
- At least 4 additional wood screws

## UNIT PARTS AND DIMENSIONS

Fan Assembly

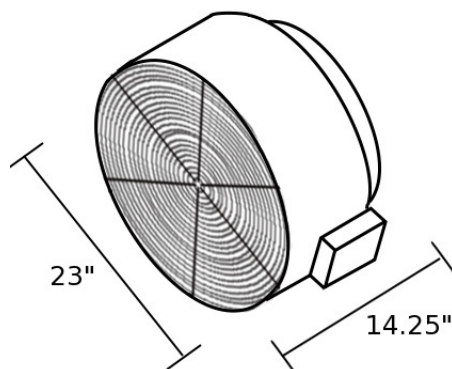

Backdraft Damper\*

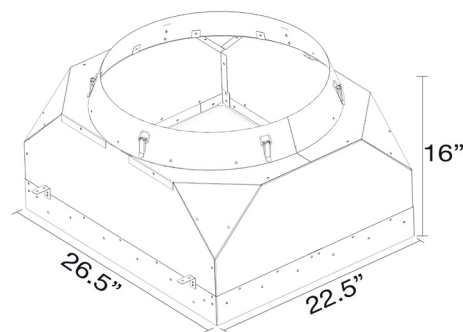

Flex Duct

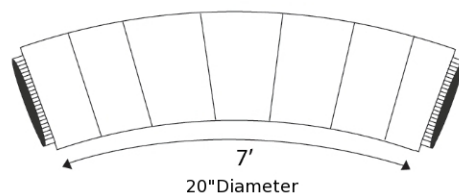

\*Backdraft Damper is shown as it appears once fully assembled.

## VENTILATION REQUIREMENTS

It is critical the attic be sufficiently ventilated for this fan to operate properly. Without adequate ventilation, hot air exhausted from the home cannot easily escape the attic, which creates a back-pressure that will substantially reduce the fan's performance. Operating this fan in an attic with less net free ventilation area than recommended will decrease its airflow and energy efficiency.

We recommend a minimum of 1 square feet of "net free" ventilation area per 500 cfm at a fan's highest speed. **Therefore, this Kohilo 2.8 whole house fan requires at least 6 square feet of net free ventilation area for proper operation.**

Net free ventilation area can be provided by any combination of gable, eyebrow, roof cap, soffit, or ridge vents, or any other method of ventilating the attic space. The openings of most vents are partially obstructed by grilles, louvers, and/or screens. A vent's "net free" ventilation area is the surface area of its opening minus the surface area of any grilles, louvers, or screening covering it. Different types of vents have different ratios of net free area to total area.

While in our experience most properly constructed homes have adequately ventilated attics, not all do. Because sufficient ventilation is so critical to this fan's performance, it is important that the home's existing ventilation be verified before it is installed.

Manufacturers typically publish their vents' net free ventilation areas and/or ratios in their products' specification documents. If this information is unavailable, a ratio of 50% net free area to total area is usually a good rule of thumb. A notable exception to this rule of thumb are ridge vents. The industry standard net free ventilation area for ridge vents is 13% of the vent's length in feet.

Since most attics have multiple vents, often of different types, it is necessary to count each vent, noting its type and size. Apply the appropriate ratio to the dimensions of each vent to find its net free area, and sum these values to find the attic's total ventilation. An example of how these calculations are made is given in the table below:

Vent Type	Dimensions	Total Area	Net Free Area Ratio ("NFA")	Net Free Ventilation Area (=Total Area x NFA)
Louver	24" x 24"	$24" \times 24" / 144 = 4 \text{ ft.}^2$	50%	$4 \text{ ft.}^2 \times .50 = 0.89 \text{ ft.}^2$
Ridge	10 feet	n/a	13%	$10 \text{ feet} \times .13 = 1.33 \text{ ft.}^2$
Round Soffit	10" diameter	$3.14 \times 5" \times 5" / 144 = .55 \text{ ft.}^2$	50%	$.55 \text{ ft.}^2 \times .50 = 0.28 \text{ ft.}^2$
<b>Total Net Free Ventilation Area:</b>				<b>1.57 ft.<sup>2</sup></b>

You can also use AirScape's online Attic Venting Calculator to assist you in determining your attic venting. This calculator is located at <http://www.airscapefans.com/system-builder/attic-vent.php>.

*Please consult a roofing professional if the attic's net free ventilation area remains uncertain.*

## WHERE TO LOCATE THIS FAN

The best location for this fan is dictated by its theory of operation: As a home heats up during the day, a large amount of heat is retained in its structure and contents. These materials give up their heat slowly and, in doing so, continue to heat the home's interior even though the outdoor temperature may, in fact, be very comfortable in the evening and at night. Thus, homeowners are forced to either endure the hot conditions inside of their homes or turn on their air conditioners and bear the expense thereof.

When operated properly, this whole house fan can resolve this dilemma by forcing the hot air inside a home out and drawing cool air from outside in. The illustration below depicts how this fan exhausts hot air into the attic and draws cool air into the house from outdoors:

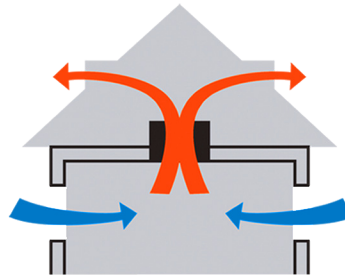

By running this fan through the night, homeowners can extract the maximum possible amount of heat from their home's structure and contents. This essentially "pre-cools" the home ahead of the next day's rise in temperature, which can reduce or even eliminate the need for air conditioning. This Kohilo fan has been designed specifically for quiet and efficient operation. As such, we strongly recommend homeowners run this fan through the night to reduce their energy expenses.

With the above theory of operation in mind, adhere to the following guidelines when choosing a location for this fan:

- Locate this fan in a central location, away from windows that will be opened during its operation. Installing this fan centrally promotes an even replacement of air throughout the home, and the longer the path air travels from an open window to the fan, the greater the cooling effect.
- The damper provided with this fan can only be installed in a horizontal orientation, thereby requiring the unit to be installed in the ceiling.
- Locate this fan at the highest point possible. This exploits natural convection and helps the fan exhaust the hottest indoor air from the home.
- Typically, the ideal location for this fan in a two-story home is in the open area at the top of the stairs.
- Avoid locating this fan in a narrow space or over hard flooring as sound reflecting off of hard surfaces can amplify its perceived noise.
- Even though this fan is extremely quiet, we specifically recommend against installing it in a bedroom as humans' perception of noise is far greater when the surrounding environment is quiet (such as within a bedroom at night).
- Within the attic, locating the fan near an electrical outlet or power supply can minimize the need for additional electrical work.

## INSTALLATION: FRAMING

The first step in installing this fan is to build a simple “box” between the framing in the ceiling and to create an opening into the attic. This fan’s backdraft damper has been designed to fit within a 22½” x 26½” ceiling opening. Most modern homes have been constructed with either 24” or 16” on-center (i.e. O/C) spaced joists or studs. This step varies slightly depending on whether the home’s framing is either 24” or 16” O/C.

### For 24” O/C Framing:

Using appropriately sized lumber (e.g. 2”x4”, 2”x”6, etc.), install two 22½” long cross peices between the existing framing, creating a box with interior dimensions of 22½” x 26½”. Figure 1 at right shows the framing and cross peices as they should be installed.

From below, cut out the drywall inside the framed box to create an opening to the attic. To know where to cut, use a stud finder to locate the studs from below or drill pilot holes from above.

### For 16” O/C Framing:

Using appropriately sized lumber (e.g. 2”x4”, 2”x”6, etc.), install four 14½” long and one 26½” long cross peices between the existing framing, as shown below in Figure 2a.

Next, use lumber to construct a second frame with interior dimensions of 22½” x 26½”. As shown below in Figure 2b, mount this new frame on top of the frame created within the joists.

From below, cut out the drywall inside the framed box to create an opening to the attic. To know where to cut, use a stud finder to locate the studs from below or drill pilot holes from above.

In this configuration, a notch will need to be cut in the Grille in order to accomodate the center joist running across the opening. Procedures for this step are included in the INSTALLATION: GRILLE section of this manual. The center joist across the opening will not significantly disturb the flow of air to the fan.

Figure 1

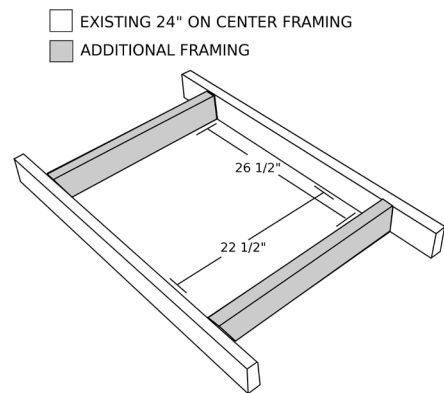

Figure 2a

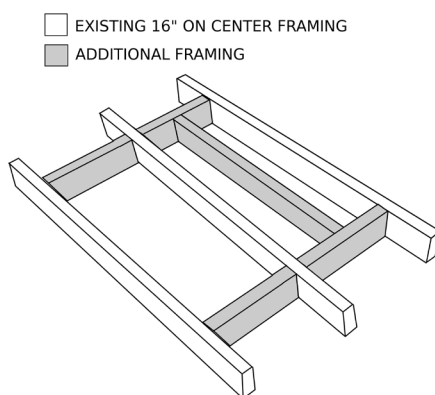
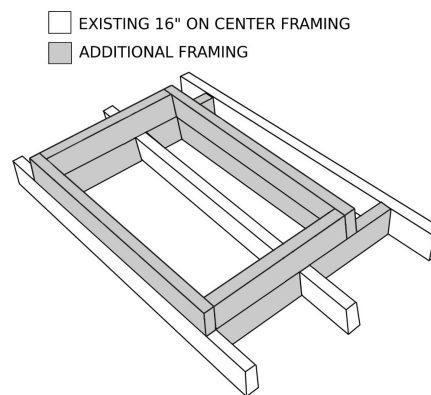

Figure 2b



## INSTALLATION: BACKDRAFT DAMPER

The next step in this fan's installation is to install the backdraft damper within the "box" that was built in the previous step.

**However, before proceeding further, please make sure to pass the fan assembly and ductwork through the opening created in the previous step and into the attic.** These items have been designed to fit through this opening. Since they may not fit through the attic's crawl hole, they *must* be in the attic before proceeding further.

If necessary, the backdraft damper transition cone can be detached from the backdraft damper itself. Simply unscrew each of the phillips head screws securing the cone to the damper (highlighted at right in Figure 3). Reattach the cone to the damper once they are in the attic.

Once the backdraft damper is in the attic. Lower the backdraft damper into the framed "box" previously constructed, resting it on the joists using the mounting brackets shown at right in Figure 4. Fasten the damper box to the joists using wood screws through the pilot holes on mounting brackets.

Then, return to the living space. Further secure the damper box to the joists with wood screws through the four pilot holes in the body of the damper box.

### ⚠ Backdraft Damper Orientation Note ⚠

The ideal orientation of unit's backdraft damper is level within the framing. If necessary, the damper's long (26.5") axis can be installed at up to a 45° angle to level, as shown in figure 5b.

However, as shown in figure 5c, the long axis must NEVER be installed at a greater than 45° angle to level. Additionally, the damper's short (22.5") axis must ALWAYS be installed level. Installing the backdraft damper outside of these constraints will prevent its doors from closing properly!

Figure 3

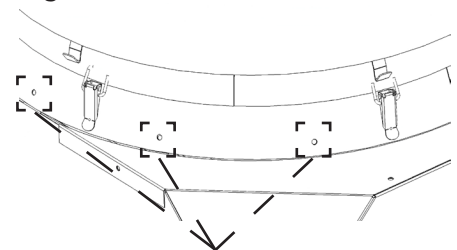

**The transition cone can be detached from the backdraft damper by unscrewing the phillips head screws connecting the two.**

Figure 4

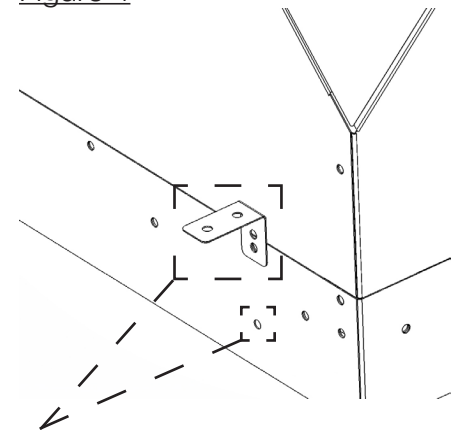

**Secure damper box to framing using wood screws at the mounting brackets and pilot holes**

Figure 5a

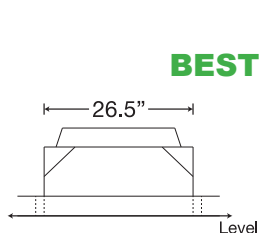

Figure 5b

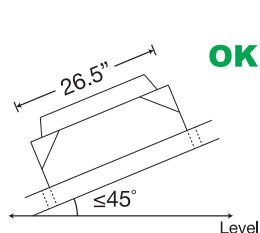

Figure 5c

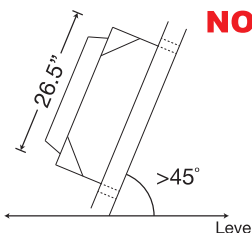

Figure 6a

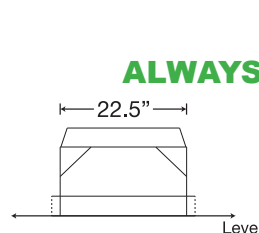
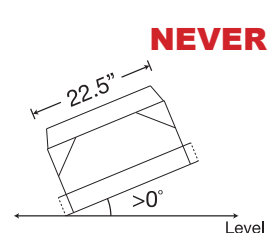

Figure 6b



## INSTALLATION: FAN & DUCT

The next step in this fan's installation is to hang the fan assembly from the attic's rafters, and to attach it to the backdraft damper using the provided ductwork. Figure 7 below shows the fan assembly, ductwork, and backdraft damper as they should appear when fully installed:

Figure 7

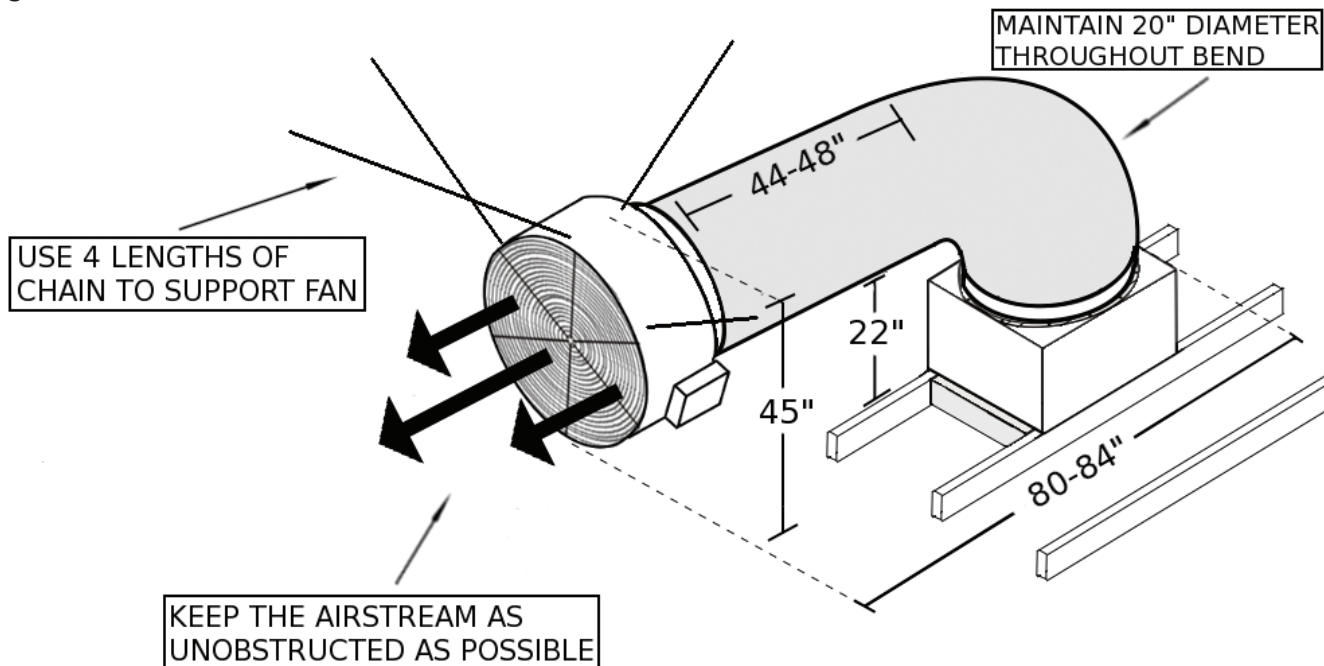

Attach 4 lengths of the provided chain to the the attic's rafters at four locations using wood screws (*NOT provided*) screwed through a chain link.

Attach the 4 provided S-hooks to 4 of the D-rings attached to the fan housing. Hang the fan assembly from the rafters using these S-hooks and the 4 lengths of chain just installed.

When hanging the fan assembly, adhere to the following guidelines:

- Do not hang the fan using fewer than 4 lengths of chains or eye bolts—all four attachment points are necessary to support the fan's weight and to eliminate any swaying motion.
- Ensure that the fan is as level as possible.
- Keep the area in front of the fan as unobstructed as possible: At the least, the nearest object obstructing the path of fan's exhaust airflow can be no closer than 24" to the face of the fan.

Next, slide one end of the flexible ductwork over the backdraft damper's transition cone and secure it thereto using the hooks on the ductwork's collar, and the latches on the cone, as shown at right in Figure 8.

If needed, the transition collar can be rotated to better align the hooks and latches. Simply unscrew the screws securing the cone to the damper (highlighted in Figure 3 on the previous page), rotate the cone, and reattach it to the damper using the screws.

Figure 8

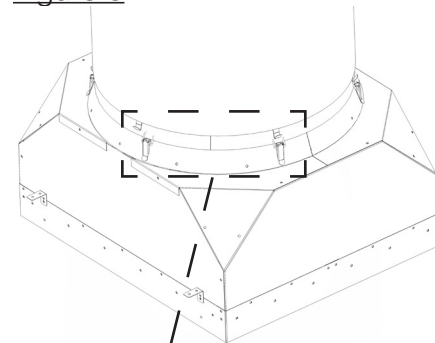

Fasten ductwork to damper using hooks and latches



Gently bend the ductwork to a 90° angle and slide the free end over the fan assembly's collar and fasten it thereto using the 4 provided self-tapping sheet metal screws and the pilot holes in the ductwork's collar, as shown at right in Figure 9.

Adhere to the following guidelines when attaching the ductwork to the backdraft damper and fan assembly:

- Make sure to maintain the full diameter of the ductwork through the bend; this provides adequate airflow and helps minimize noise.
- Avoid sharp bends in the ductwork or contact with metal fixtures, pipes, or conduits.
- The section of ductwork immediately before the fan should be as straight as possible.
- The ductwork can be supported under the bend using extra chain wrapped with a protective material (e.g. carpet).

Figure 9

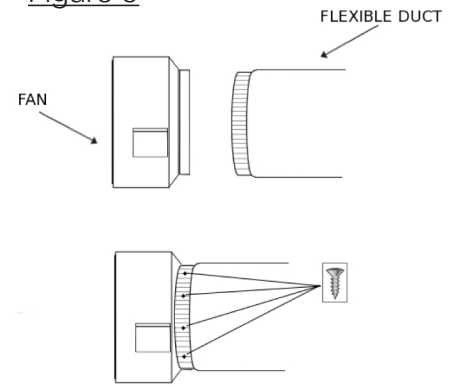

Once the fan assembly is balanced and secure, use pliers to close all of the S-hooks to ensure stability, and tape down all unused D-rings to avoid excess rattling.

Lastly, use the provided foil tape to seal the joints between the fan assembly and ductwork, the ductwork and the transition cone, and the transition cone and backdraft damper.

## INSTALLATION: GRILLE

The next step in this fan's installation is to mount the cube core grille over the interior opening in the ceiling previously created. First, from the living area, use latex caulk to seal all wood-to-wood and wood-to-metal joints. This ensures that all air drawn into the fan will be from within the living space.

Then, attach the grille to the joists using the 8 provided white head screws. We advise pre-drilling pilot holes for these screws. If the home's framing is 16" O/C, use a dremel tool or hacksaw to cut two notches in the grille's flange to accommodate the middle stud (Figure 10 below shows this notch).

Figure 10

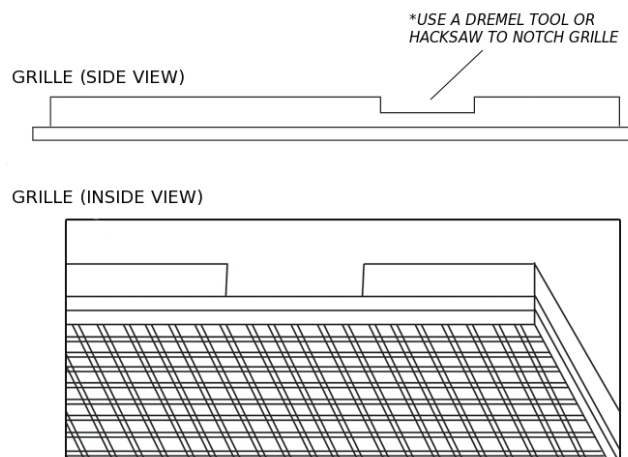

## INSTALLATION: WIRING

The final step in this fan's installation is connecting it to electricity.

**Make sure the appropriate circuit breakers at the home's electrical panel are turned OFF before wiring this unit.** All wiring and connections must be made according to this manual and acceptable wiring standards. All local codes must be followed. Consult an electrician if necessary.

The electrical switch or timer and wiring needed to operate this fan have NOT been provided. With regard to wiring, Romex 14/3 is most commonly used, and is widely available.

As shown below in Figure 11, run 3-wire cable from the household 115v supply to the customer-supplied switch or timer, and then to the junction box located on the fan assembly. Connect the wire ends to the terminal connections in the junction box: Neutral to White; Line to Black; and, Green to Ground.

Figure 11

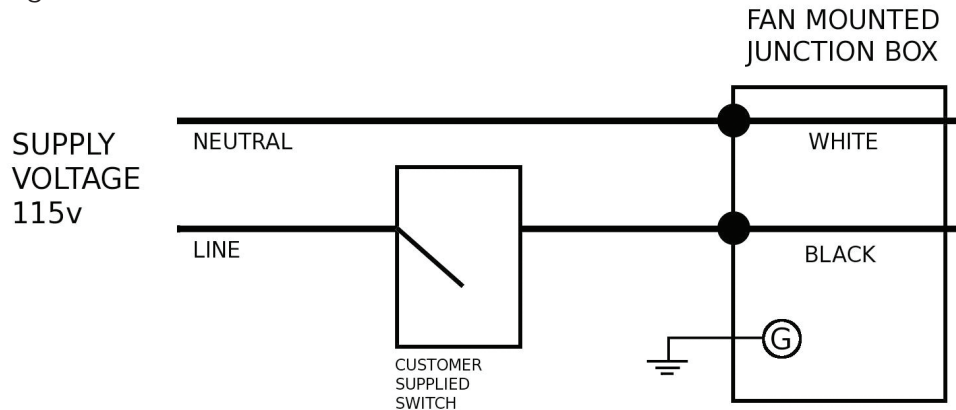

## START-UP & OPERATION

Before starting this fan for the first time, verify that:

1. All wiring and connections have been made according to this manual and acceptable wiring standards, and that this manual and all local codes and standards have been followed in this fan's installation; and,
2. No tools or construction debris have been left in, on, or around the fan.

Make sure the fan's switch is OFF, then turn on the appropriate circuit breakers at the home's electrical panel.

Next, turn the fan ON. The fan will turn on and the backdraft damper will open. If the fan does not turn on, check power to the unit and the wiring at both ends of the switch and the fan-mounted junction box. If the damper does not open, visually inspect it for any debris obstructing its movement.

When the fan is turned OFF, the fan will shut down and the backdraft damper's flaps will fall closed.

**Make sure the appropriate circuit breakers at the home's electrical panel are turned OFF before servicing this fan.**

There is no routine maintenance required for this fan other than making sure the fan assembly and back-draft damper are kept clean of any possible build up of debris.

Blocking this fan's exhaust can cause it to fail prematurely. Keep the area in front of the fan as unobstructed as possible: no object should be closer than 24" to the face of the fan.

Resettable circuit breakers are located on the control box and fan mounted electrical box to protect circuit boards from power surges. In the case of a power surge, these breakers can be reset by simply pushing the button back in.

This fan has been factory tested. If problems are encountered, please take a few moments to run through the following troubleshooting procedures before calling for assistance:

- If the fan does not turn on, check power to the unit and the wiring at both ends of the switch and the fan-mounted junction box.
- If the damper flaps do not open or close, visually inspect the damper for any debris obstructing their movement.

If the suggestions above do not work, contact AirScape technical support at 866.448.4187 or by email at [experts@airscapefans.com](mailto:experts@airscapefans.com) for further assistance.

## WARRANTY

### **Hardware**

AirScape warrants the original end user (“Customer”) that new AirScape Whole House fan products, including all moving parts, motors, dampers, and damper actuators will be free from defects in workmanship and materials, under normal use, for three (3) years from the original purchase date.

### **Software**

AirScape warrants to Customer that the AirScape Whole House Fan software will perform in substantial conformance to its program specifications for a period of three (3) years from the date of the original purchase.

### **Exclusions**

This warranty excludes (1) physical damage to the surface of the product, including cracks or scratches on the outside casing; (2) damage caused by misuse, neglect, improper installation, unauthorized attempts to open, repair, or modify the product, or any other cause beyond the range of intended use; (3) damage, caused by accident, fire, power changes, other hazard, or Acts of God; or (4) use of the product with any unauthorized device if such device causes the problem.

### **Exclusive Remedies**

Should a covered defect occur during the warranty period and Customer notifies AirScape, Customer’s sole and exclusive remedy will be, at AirScape’s sole option and expense, to repair or replace the product. Replacement products or parts may be new or reconditioned or a comparable version of the defective item. AirScape warrants any replaced product or part for a period of ninety (90) days from shipment, or through the end of the original warranty, whichever is longer.

### **Obtaining Warranty Service**

Customer must contact and return product to AirScape, Product dealer or Installer within the applicable warranty period to obtain warranty service. Dated proof of original purchase will be required. AirScape will not be responsible for Customer’s memory data contained in, stored on, or integrated with any products returned to AirScape for repair, whether under warranty or not.

### **Warranty Exclusive**

The forgoing warranties and remedies are exclusive and in lieu of all other Warranties, express or implied, including warranties of merchantability, Fitness for a particular purpose, correspondence with description, and Non-infringement, all of which are expressly disclaimed by AirScape and its suppliers.

### **Disclaimer**

Neither AirScape nor its suppliers shall be liable for incidental, consequential, indirect, special, or punitive damages of any kind, or financial loss arising out of or in connection with the sale or use of this product, whether based in contract, Tort (including negligence) or any other theory, even if AirScape has been advised of the possibility of such damages AirScape’s entire liability shall be limited to replacement or repair of the product.

## SPECIFICATIONS

Speed Settings:	1
Tested Airflow:	2850 cubic feet per minute
Tested Electricity Consumption:	297 watts
Tested Efficiency:	9.6 cubic feet per minute per watt
Tested Noise:	47.5 dBA (tested at 45° and 1 meter from source)
Rough Opening Dimensions:	22.5" x 26.5"
Grille Outer Dimensions:	24.5" x 28.5"
Grille Build:	Cube Core, Aluminum, White Powder Coat
Backdraft Damper Dimensions:	26.375" x 22.25" x 12.5" (L x W x H)
Duct Length:	7 ft.
Duct Diameter:	20"
Electrical:	115VAC, 60 Hz
Insulation:	-none-
Installation:	Installs easily on 24" or 16" O/C framing
Warranty:	3 years

\*Due to our continual product improvement efforts, performance ratings and specifications are subject to change without notice.

## INSTALLATION NOTES