

KETER

Create amazing spaces™

®

MANUAL

RIO SET

**USER MANUAL | MODE D'EMPLOI | MANUAL DEL USUARIO | MONTAGEANLEITUNG |
MONTAGEHANDLEIDING | MANUALE PER L'UTENTE | MANUAL DO UTILIZADOR**

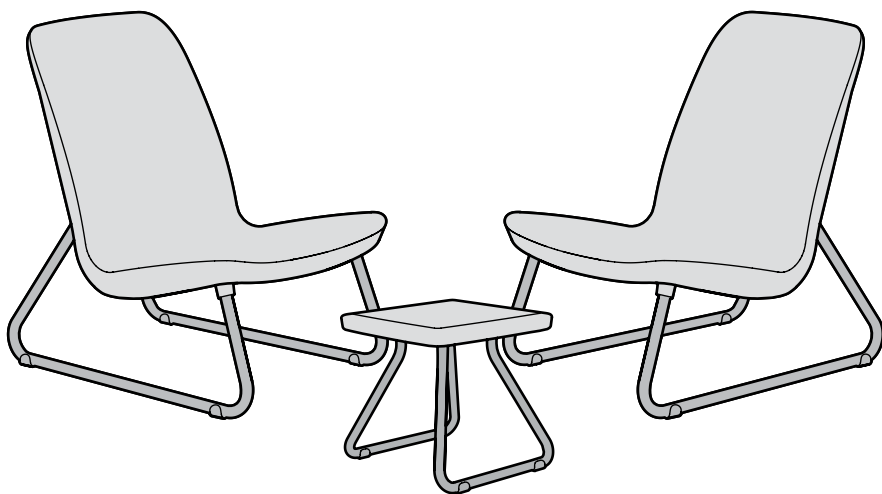

WWW.KETER.COM

US, Canada

Tel: +1877-638-7056, NACS@keter.com

UK

Tel: +44-121-506-0008, CSUK@keter.com



5011163



- **Attention - instructions to be kept for further reference.**
- **Position in a stable way on a flat ground.**
- **Spare parts not available beyond guarantee.**
- Important – a conserver pour une consultation ultérieure, à lire attentivement.
- Positionner de manière stable sur un sol plan.
- Pièces détachées non disponibles hors garantie.
- **Atención – guardar las instrucciones para futura referencia.**
- **Colocar en una posición estable sobre terreno llano.**
- **Piezas de repuesto no disponibles finalizada la garantía.**
- Achtung - anleitung soll als zukünftige referenz aufbewahrt werden.
- Stabil auf ebenem Boden aufstellen.
- Ersatzteile nach auslaufen der garantie nicht erhältlich.
- **Attenzione: le istruzioni devono essere conservate con cura per riferimenti futuri.**
- **Posizionare in maniera stabile o su un terreno piano.**
- **Pezzi di ricambio non disponibili superato il periodo di garanzia.**
- Let op – instructies moeten voor toekomstige raadpleging worden bewaard.
- Plaats op stabiele wijze op een vlakke ondergrond.
- Reserveonderdelen zijn niet verkrijgbaar na de garantieperiode.
- **Atenção - as instruções devem ser guardadas para referência futura.**
- **Posicionar numa forma estável num piso plano.**
- **As peças sobressalentes não estão disponíveis além da garantia.**

ASSEMBLY PARTS | PIÈCES À ASSEMBLER | PIEZAS DE ENSAMBLE | MONTAGETEILE | PARTI DA MONTARE | ONDERDELEN | PEÇAS DE MONTAGEM

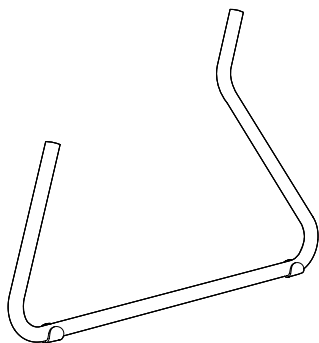

(x4)

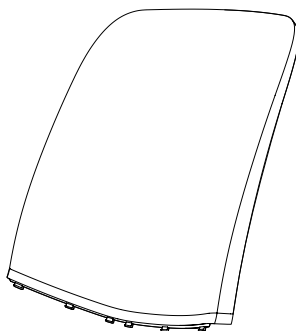

B (x2)

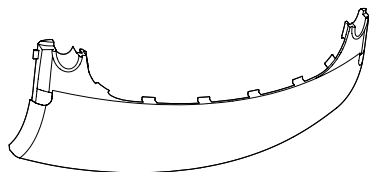

BC (x2)

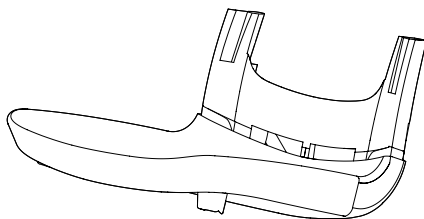

S (x2)

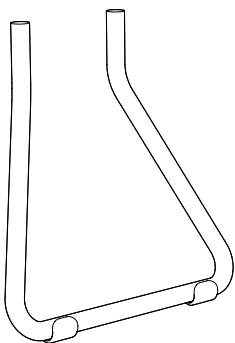

(x2)
4



TT (x1)

x2

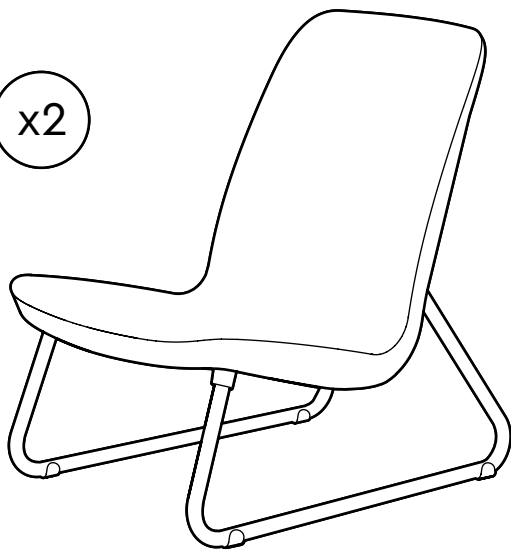

1

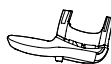

S (x1)



(x2)

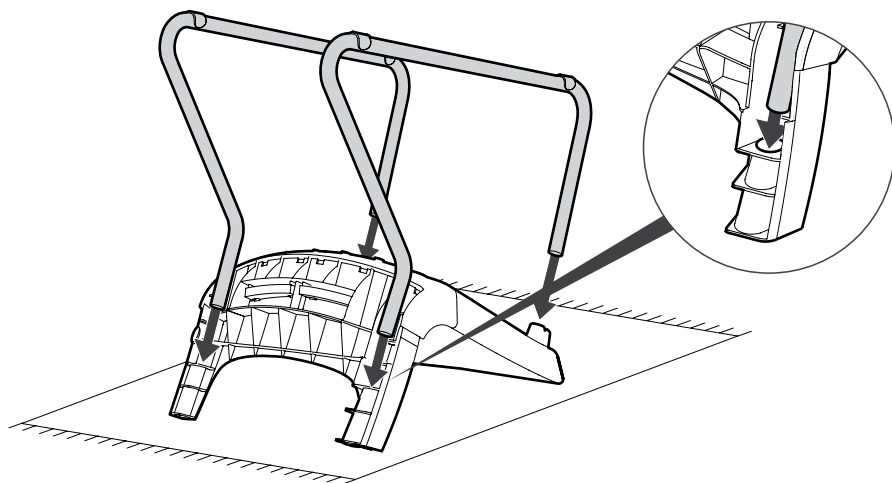

2



B (x1)

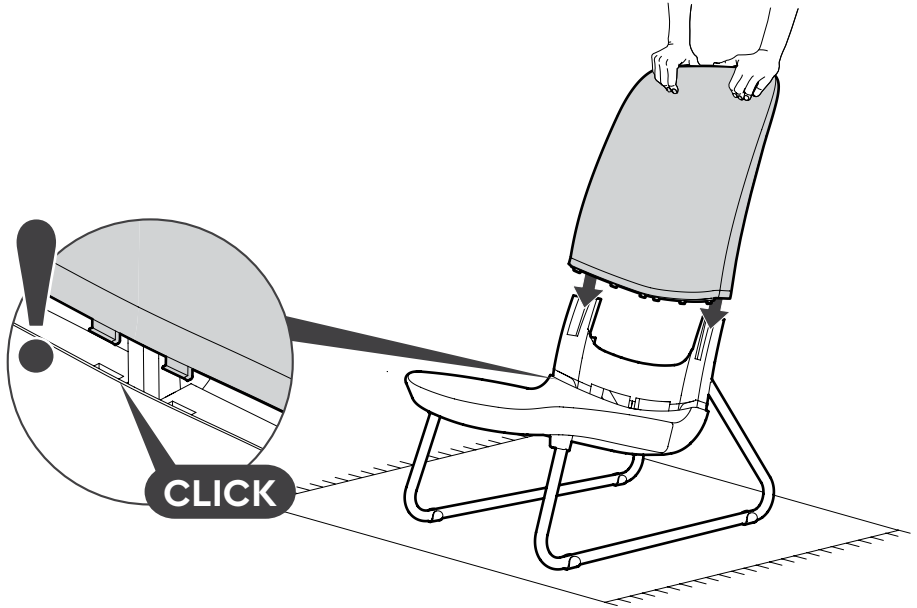

3



BC (x1)

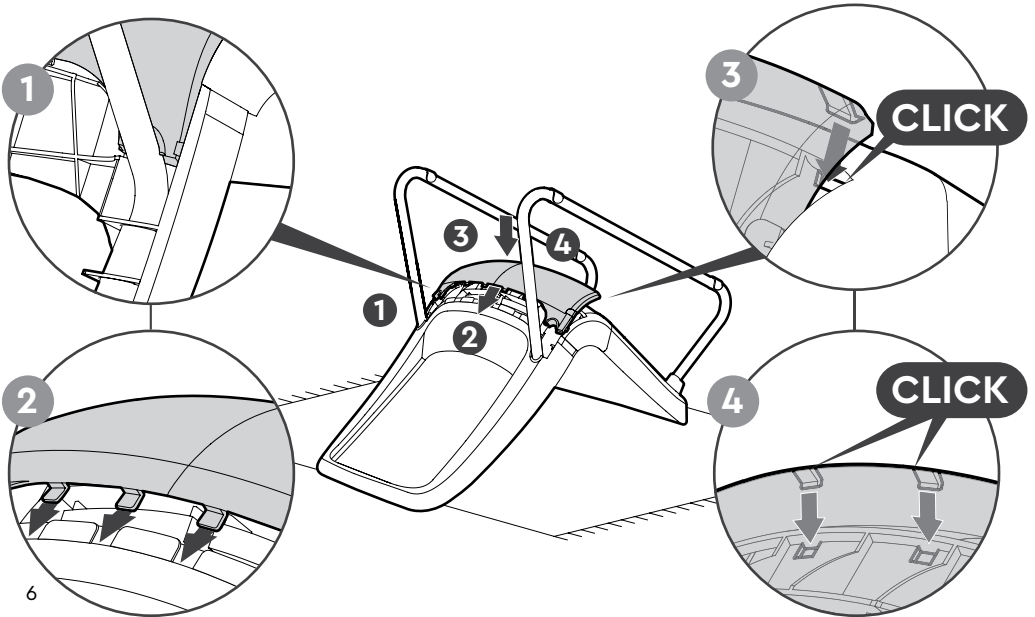

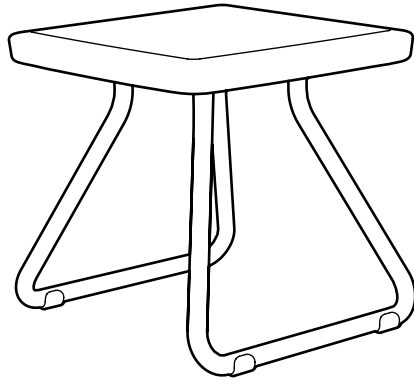

1



TT(x1)



(x2)

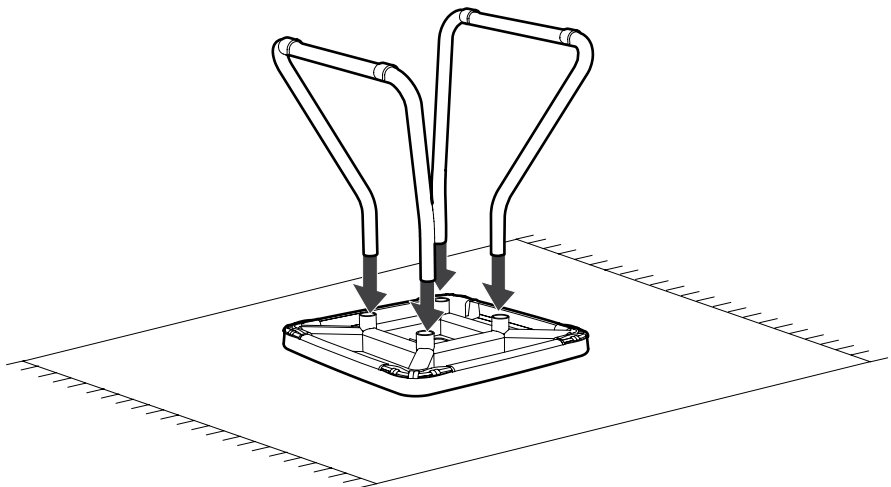



For any assistance, please contact customer service.

Pour toute assistance, veuillez contacter notre service clientèle | **Para solicitar ayuda por favor, póngase en contacto con nuestro servicio al cliente** | Bitte kontaktieren Sie unseren Kundenservice, falls Sie Hilfe benötigen | **Voor ondersteuning, gaarne contact opnemen met onze klantendienst** | Per qualsiasi tipo di assistenza, potete contattare il nostro servizio clienti | **Para obter assistência, favor contatar nosso atendimento ao cliente em.**

WWW.KETER.COM

USA & Canada

Tel: 877-638-7056
08:00 AM -17:00 PM

UK | ROYAUME-UNI

Tel: 0121 506 0008
08:30 AM -17:00 PM

FRANCE*

Please contact customer service department at the store |
Veuillez contacter le service après-vente de votre point de vente

BENELUX | BENELUX

Tel: +31 (0) 161 228300
9:00 AM -17:00 PM

GERMANY | AUSTRIA

Tel: +49 (0) 481 21 22 46 3
09:00 AM -17:00 PM

IBERIA

Tel: +949 27 74 21
09:00 AM -17:00 PM

SWITZERLAND

Tel: +41 62 767 00 50
09:00 AM -17:00 PM

AUSTRALIA:

Our goods come with guarantees that cannot be excluded under the Australian Consumer Law. You are entitled to a replacement or refund for a major failure and for compensation for any other reasonably foreseeable loss or damage. You are also entitled to have the goods repaired or replaced if the goods fail to be of acceptable quality and the failure does not amount to a major failure.

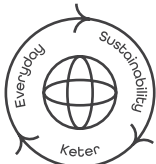

Designed to Last | Conçu pour durer | Diseñado para durar | Auf Langlebigkeit ausgelegt | Duurzaam ontworpen | Progettato per durare | Projetado para durar



Recyclability & Recycling | Recyclabilité et Recyclage | Reciclabilidad y reciclable | recyclefähig & recycelt | Recyclebaarheid & recycling | Riciclabilità e Riciclo | Reciclabilidade e Reciclagem



Community | Communauté | Comunidad | Community | Community | Comunità | Comunidade



Responsible Manufacturing | Fabrication responsable | Producción responsable | Verantwortungsbewusste Herstellung | Verantwoorde productie | Produção responsável | Fabricação responsável



5011163