

KETER

Create amazing spaces

ALPINE ADIRONDACK

USER MANUAL | MODE D'EMPLOI | **MANUAL DEL USUARIO** | GEBRAUCHSANLEITUNG |
GEBRUIKSHANDLEIDING | MANUALE PER L'UTENTE | **MANUAL DO UTILIZADOR**

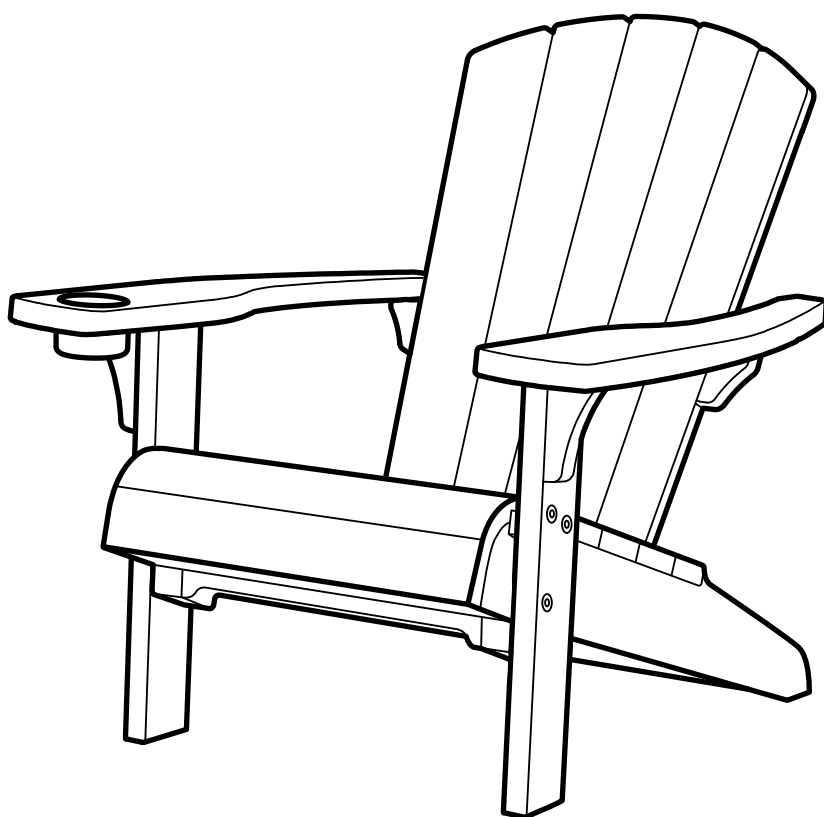

Try
it!

5004985

New Interactive Assembly Instructions

Nouvelles instructions de montage interactives

Nuevas instrucciones de montaje interactivas

Neue interaktive Montageanleitung

Nieuwe interactieve montage-instructies

Nuove istruzioni di montaggio interattive





Novas Instruções de Montagem Interativas

SCAN or VISIT US

<https://g.keter.com/alpine-adirondack>

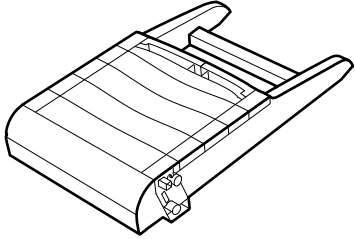
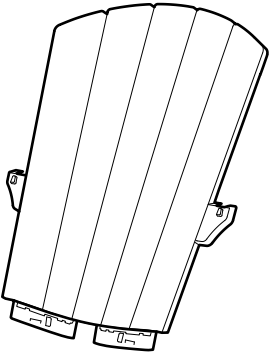
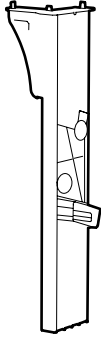
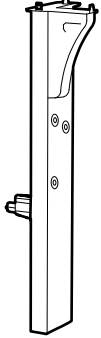

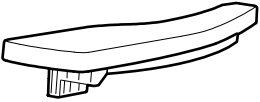
ASSEMBLY PARTS | PIÈCES À ASSEMBLER | PIEZAS DE ENSAMBLE | MONTAGETEILE | PARTI DA MONTARE | ONDERDELEN | PEÇAS DE MONTAGEM |

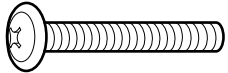
 <p>Sx1</p>	 <p>Bx1</p>	 <p>RLx1</p>	 <p>LLx1</p>
 <p>RSx1</p>	 <p>LSx1</p>	 <p>x10</p>	 <p>1/4 Inch x10</p>

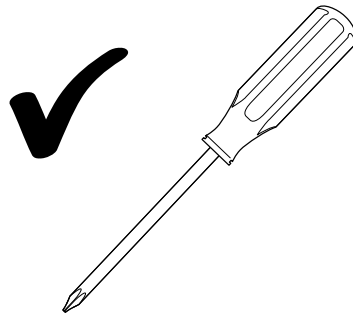



- **Attention - instructions to be kept for further reference.**
- **Position in a stable way on a flat ground.**
- **Spare parts not available beyond guarantee.**
- Important - a conserver pour une consultation ultérieure, à lire attentivement.
- Positionner de manière stable sur un sol plan.
- Ne pas se mettre debout sur le fauteuil.
- Pièces détachées non disponibles hors garantie.
- **Atención – guardar las instrucciones para futura referencia.**
- **Colocar en una posición estable sobre terreno llano.**
- **Piezas de repuesto no disponibles finalizada la garantía.**
- Achtung - anleitung soll als zukünftige referenz aufbewahrt werden.
- Nutzungsklassen des produkts: für camping, im haus und gewerblich.
- Ersatzteile nach auslaufen der garantie nicht erhältlich.
- **Attenzione: le istruzioni devono essere conservate con cura per riferimenti futuri.**
- **Posizionare in maniera stabile o su un terreno piano.**
- **Pezzi di ricambio non disponibili superato il periodo di garanzia.**
- Let op – instructies moeten voor toekomstige raadpleging worden bewaard.
- Plaats op stabiele wijze op een vlakke ondergrond.
- Reserveonderdelen zijn niet verkrijgbaar na de garantieperiode.
- **Atenção - as instruções devem ser guardadas para referência futura.**
- **Posicionar numa forma estável num piso plano.**
- **As peças sobressalentes não estão disponíveis além da garantia.**

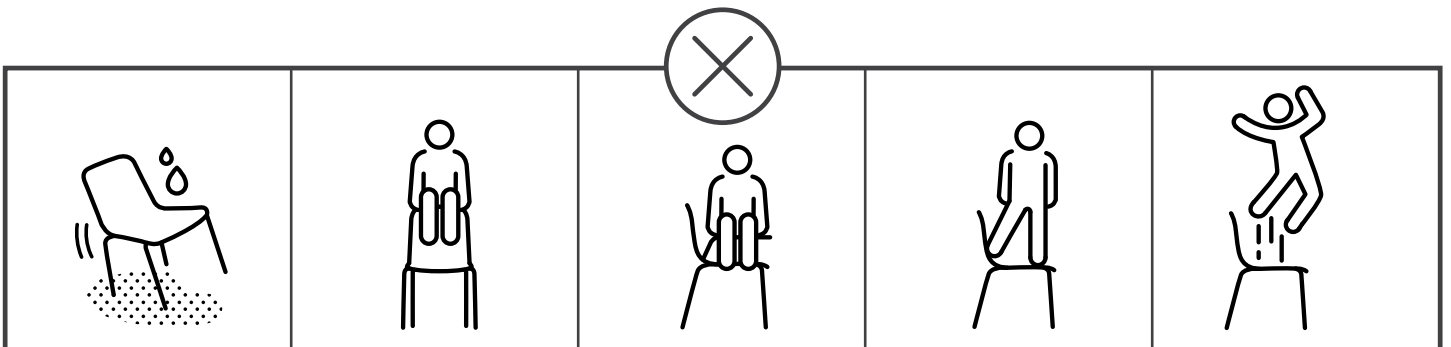
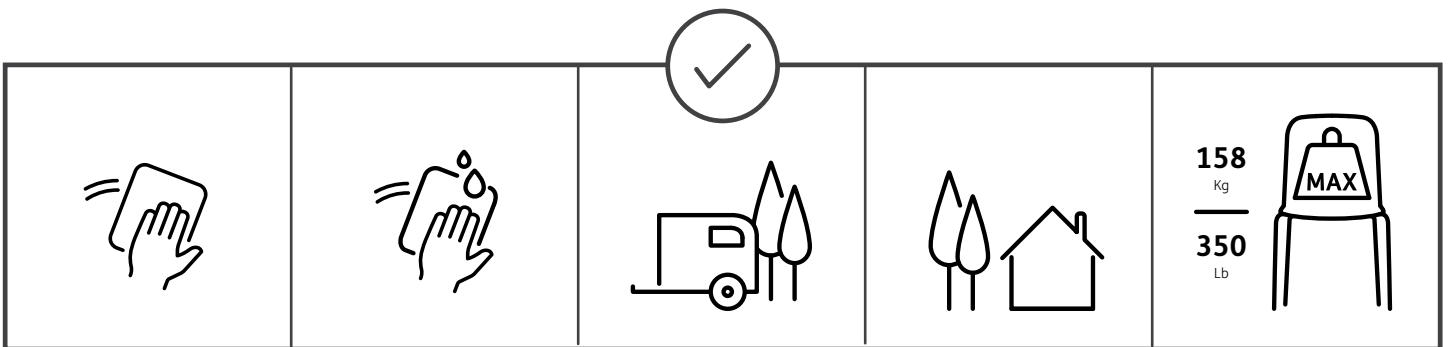

1

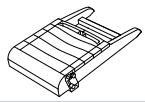

Sx1



Bx1

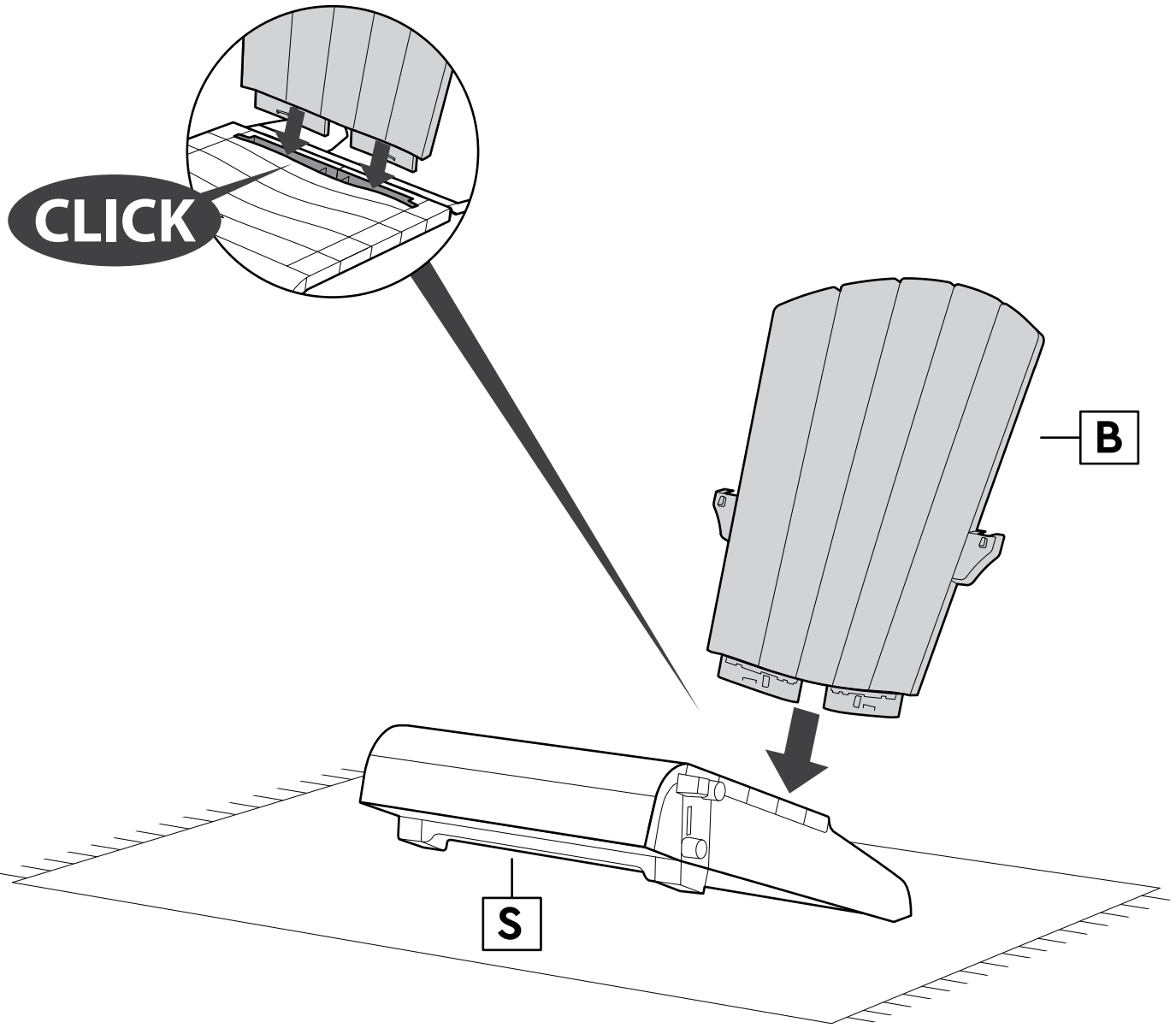

2



x3

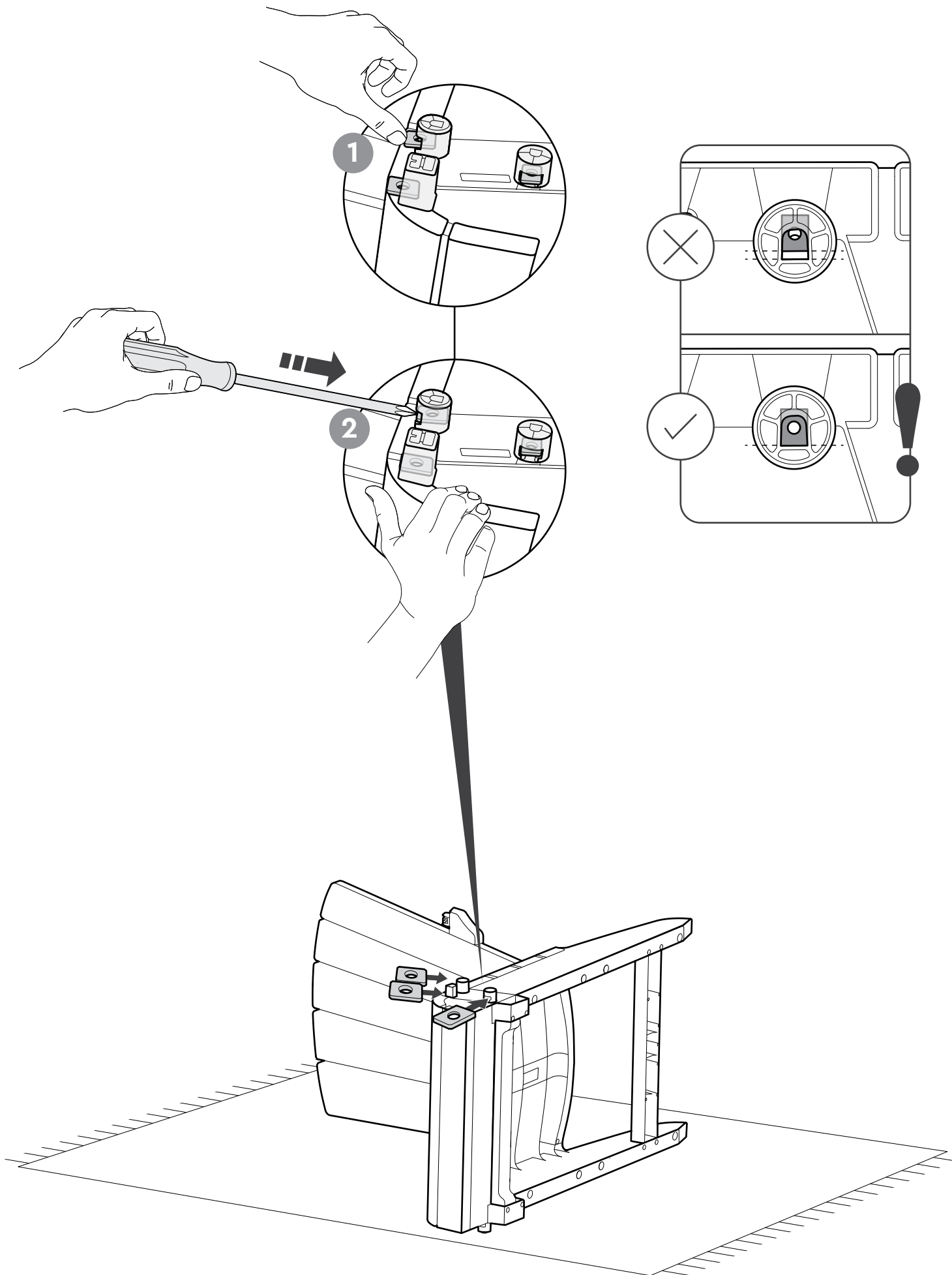

3



LLx1

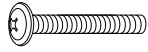

1/4 Inch x3

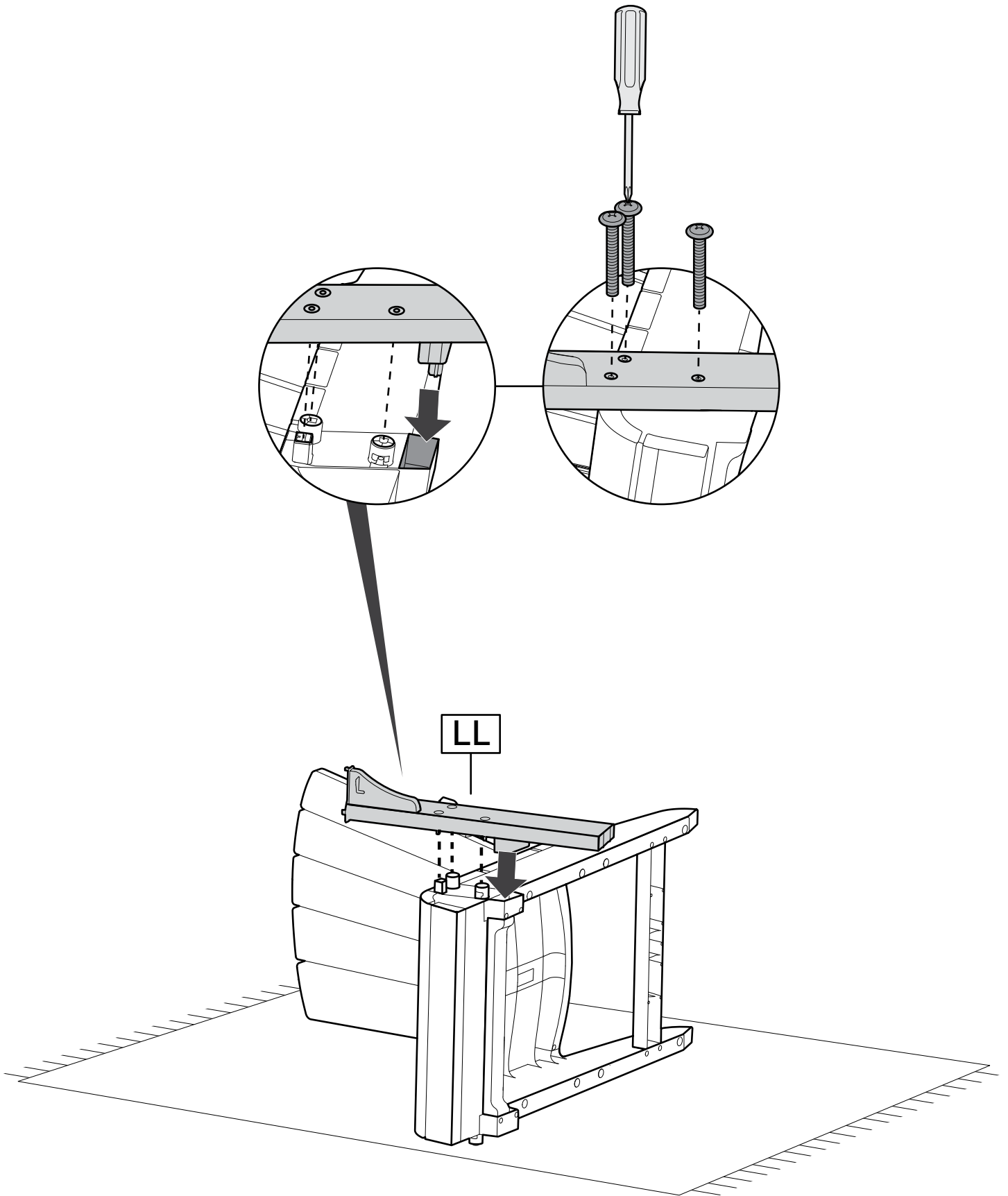

4



x3

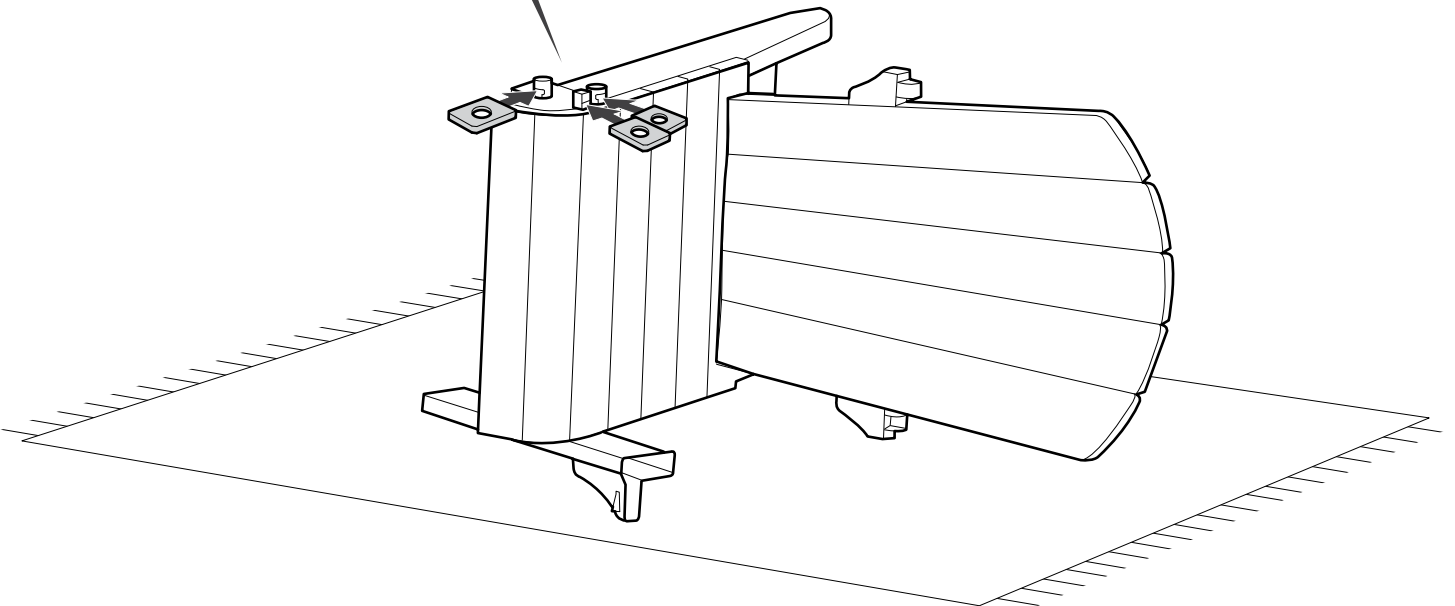
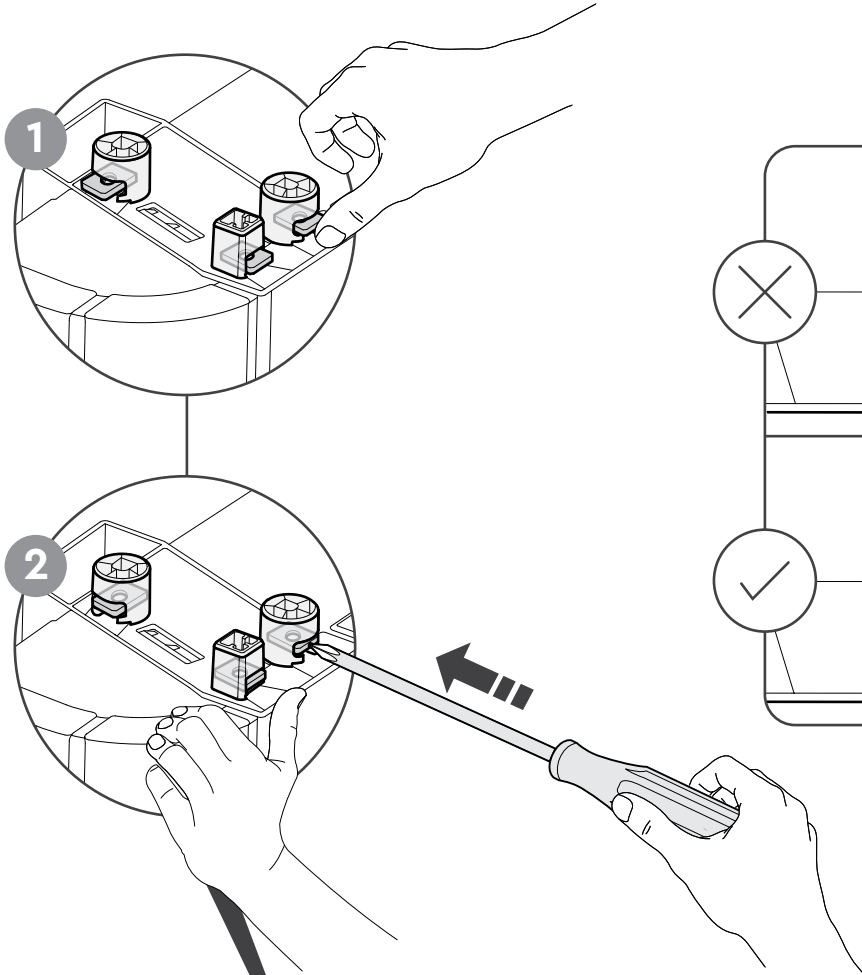
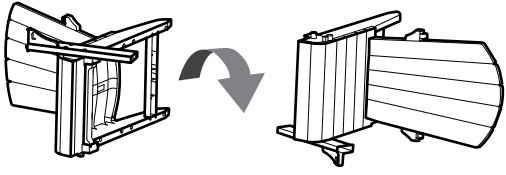

5



RLx1

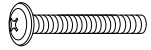

1/4 Inch x3

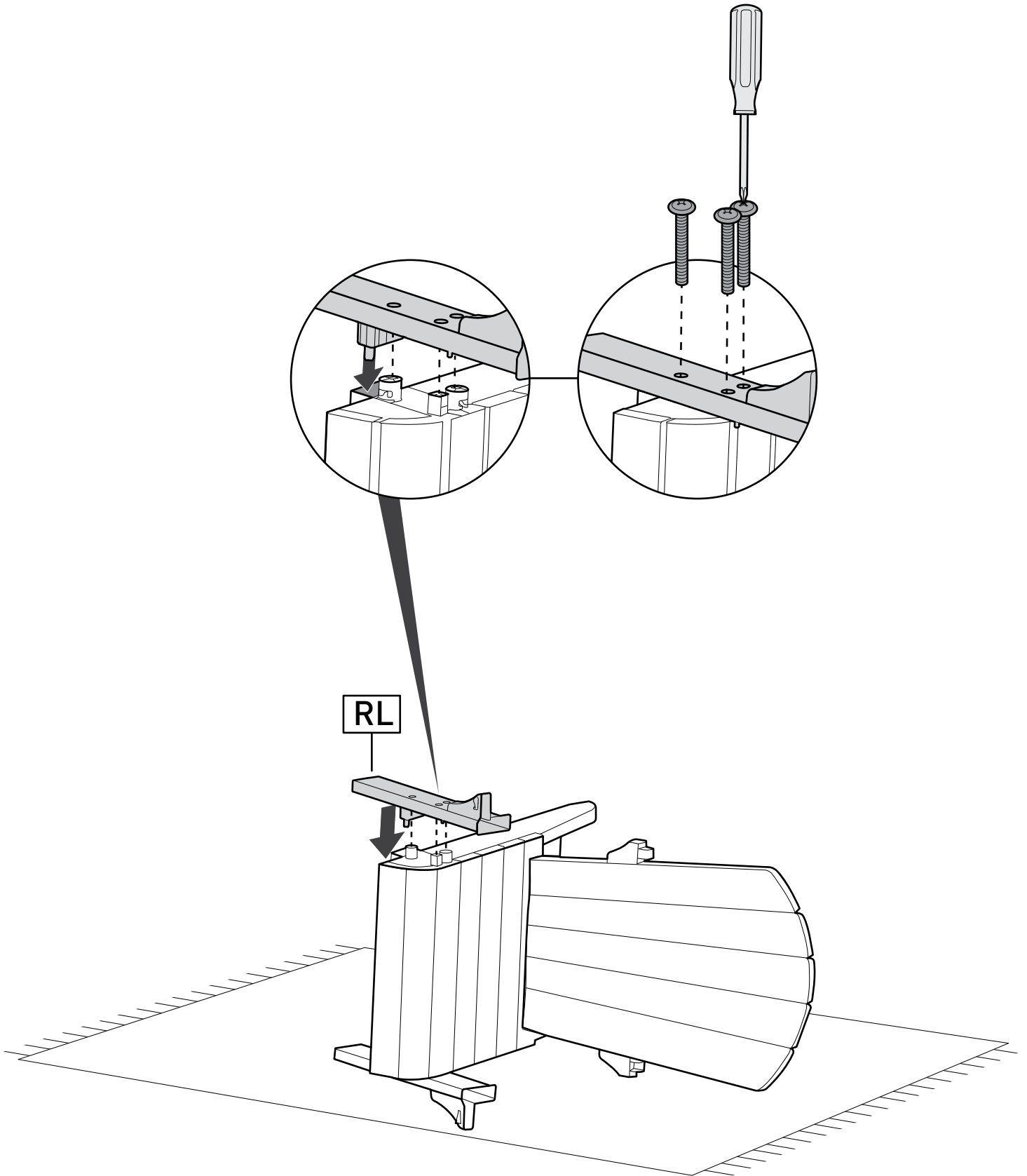

6



RSx1

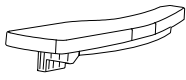

LSx1



x4

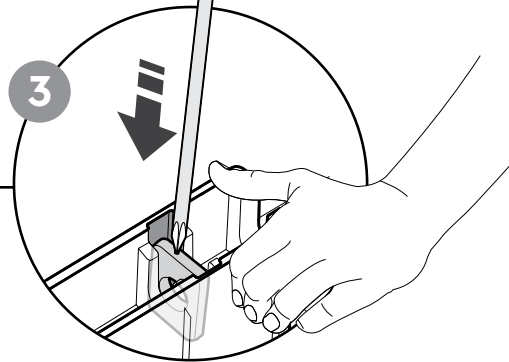
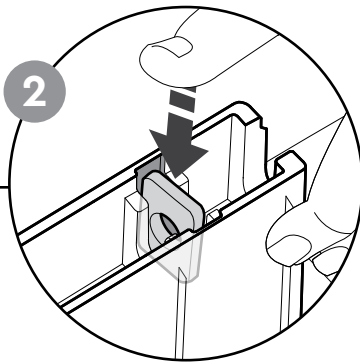
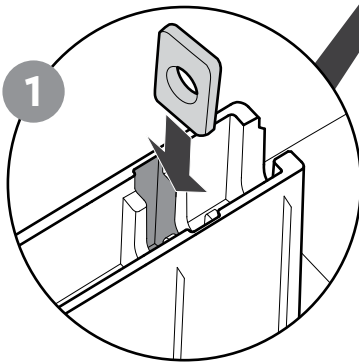
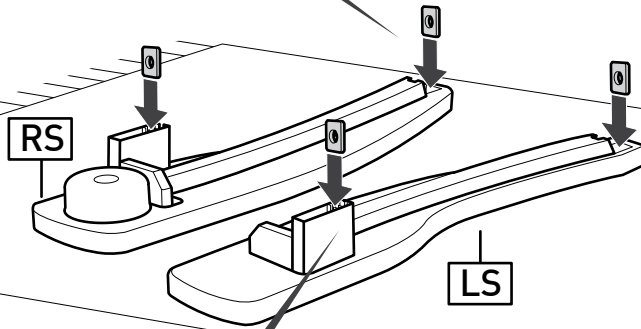
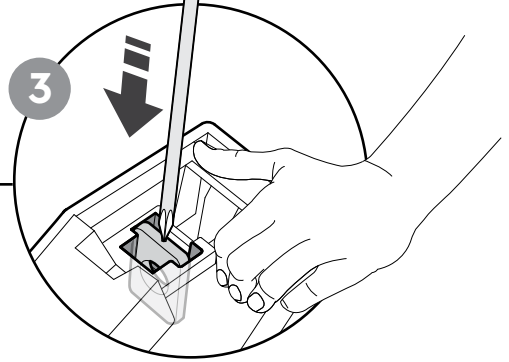
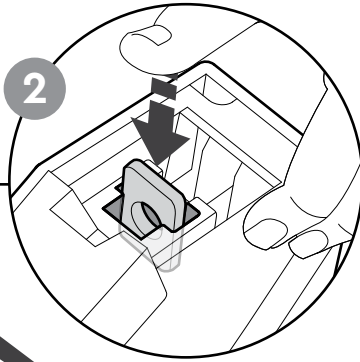
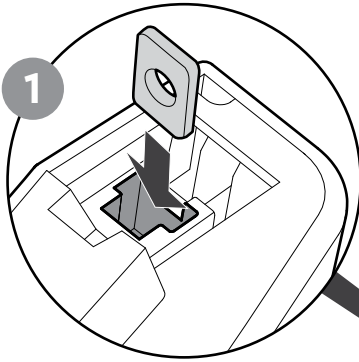

7



RSx1

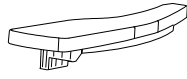

LSx1

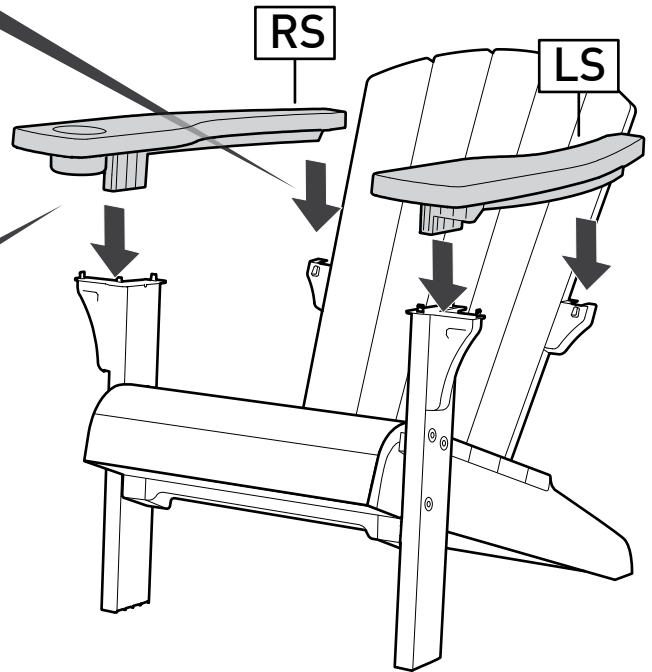
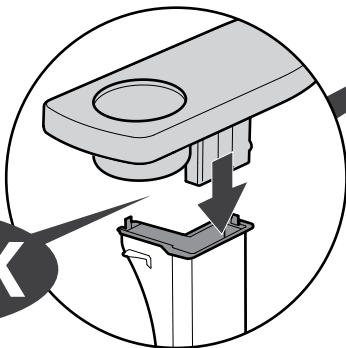
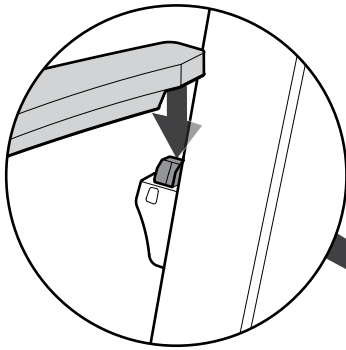

8

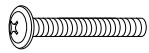

1/4 Inch x4

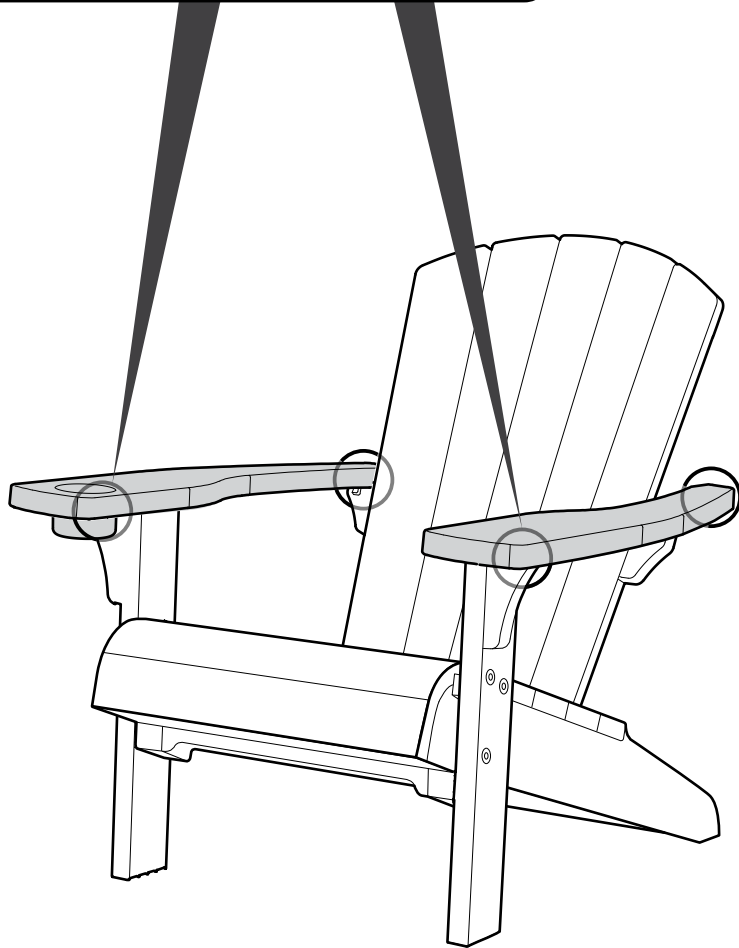
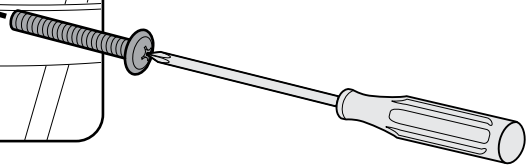
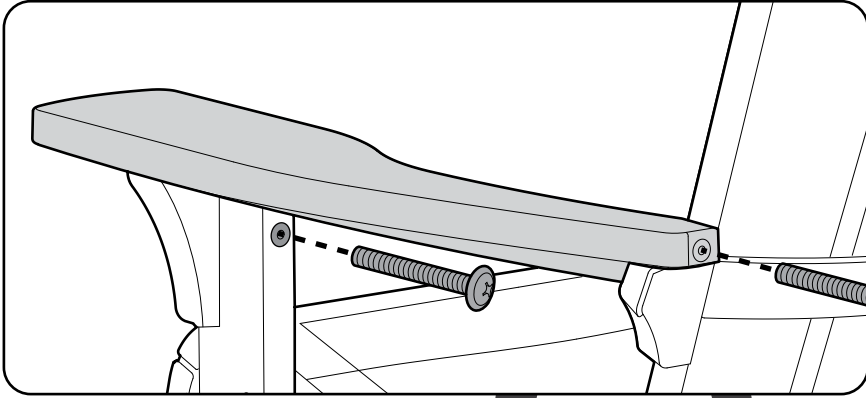



**IF THERE ARE MISSING OR BROKEN PARTS, PLEASE DO NOT RETURN THE PRODUCT TO THE STORE.
Please log onto our website, or contact Customer Service at:**

S'IL Y A DES PIÈCES MANQUANTES OU CASSÉES, NE RETOURNEZ PAS LE PRODUIT AU MAGASIN.
Veuillez visiter notre site Internet, ou contacter le Service Client*:

SI HUBIERA ALGUNA PARTE FALTANTE O DAÑADA, NO DEVUELVA EL PRODUCTO A LA TIENDA.
Inicie sesión en nuestro sitio en Internet o contáctese con nuestro servicio de atención al cliente:

BITTE BRINGEN SIE IHR PRODUKT NICHT GLEICH ZUM LADEN ZURÜCK, FALLS TEILE FEHLEN ODER DEFEXT SIND.
Bitte loggen Sie in unsere Website ein oder wenden Sie sich an unseren Kundenservice:

IN GEVAL VAN ONTBREKENDE OF GEBROKEN ONDERDELEN NIET HET PRODUCT NAAR DE WINKEL RETOURNEREN.
Ga naar onze website of neem contact op met de Klantenservice:

IN CASO DI PARTI MANCANTI O DANNEGGIATE, EVITARE DI RESTITUIRE IL PRODOTTO AL NEGOZIO.
Accedere al nostro sito o contattare il Servizio Clienti:

SE HOUVER PEÇAS EM FALTA OU PARTIDAS, NÃO DEVOLVA O PRODUTO À LOJA.
Entre na nossa página de Internet ou contacte o Serviço de Clientes:

WWW.KETER.COM

USA & Canada

Tel: 877-638-7056
08:00 AM -17:00 PM

UK | Royaume-Uni

Tel: 0121-506-0008
08:30 AM -17:00 PM

Australia:

Our goods come with guarantees that cannot be excluded under the Australian Consumer Law. You are entitled to a replacement or refund for a major failure and for compensation for any other reasonably foreseeable loss or damage. You are also entitled to have the goods repaired or replaced if the goods fail to be of acceptable quality and the failure does not amount to a major failure.

Benelux | Benelux

Tel: +31 (0) 161-228300
9:00 AM -17:00 PM

Germany | Austria

Tel: +49 (0) 481-21-22-46-3
09:00 AM -17:00 PM

Iberia

Tel: +949-27-74-21
09:00 AM -17:00 PM

Switzerland

Tel: +41-62-767-00-50
09:00 AM -17:00 PM

France*

Please contact customer service department at the store / Veuillez contacter le service après-vente de votre point de vente



KETER

NOS SOUCIONS | NOS IMPORTA

A better world with Keter.

From material innovation to manufacturing processes we encourage sustainable consumption.

Un monde meilleur avec Keter.

Du matériau innovant aux process de fabrication nous encourageons le développement durable.

Un mundo mejor con Keter.

Desde la innovación de materiales hasta los procesos de fabricación nosotros alentamos al consumo sustentable.

Für eine bessere Welt mit Keter.

Von der Materialinnovation bis zum Herstellungsprozess fördern wir Nachhaltigkeit.

Een betere wereld met Keter.

Van materiaalinnovatie tot aan de productieprocessen stimuleren wij duurzame consumptie.

Un mondo migliore con Keter.

Dall'innovazione dei materiali ai processi produttivi noi ci impegniamo per il consumo sostenibile.

Um mundo melhor com Keter.

Desde inovação de material ate os processos de fabricação nos alentamos o Consumo Sustentável.

KETER