

- A Oil pressure/dump valve assembly
- B Cartridge: see Figure 2
- C Gas ballast check valve assembly
- D Motor starting relay
- E Motor top cover
- 202 Inlet valve assembly: see Figure 4

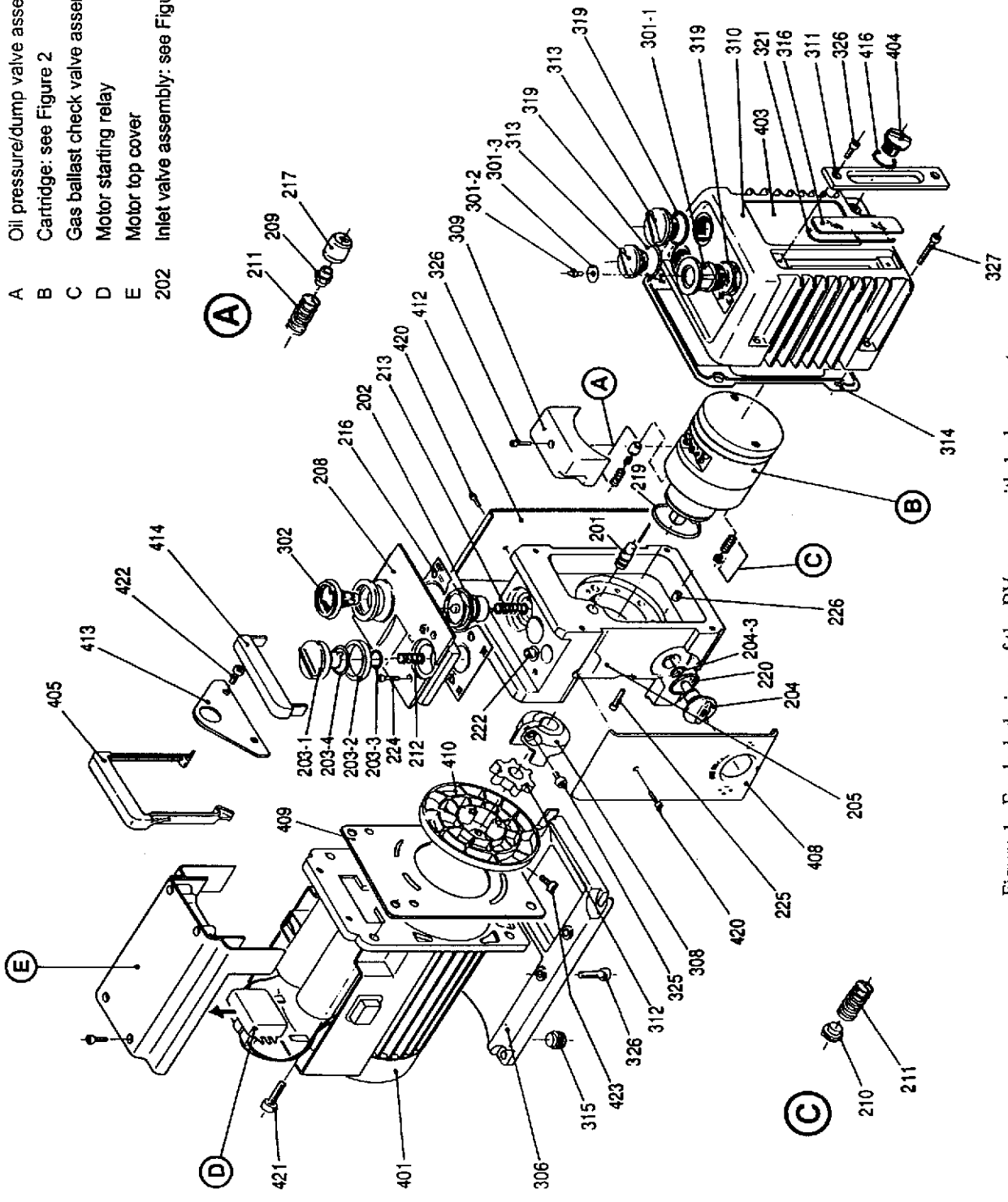
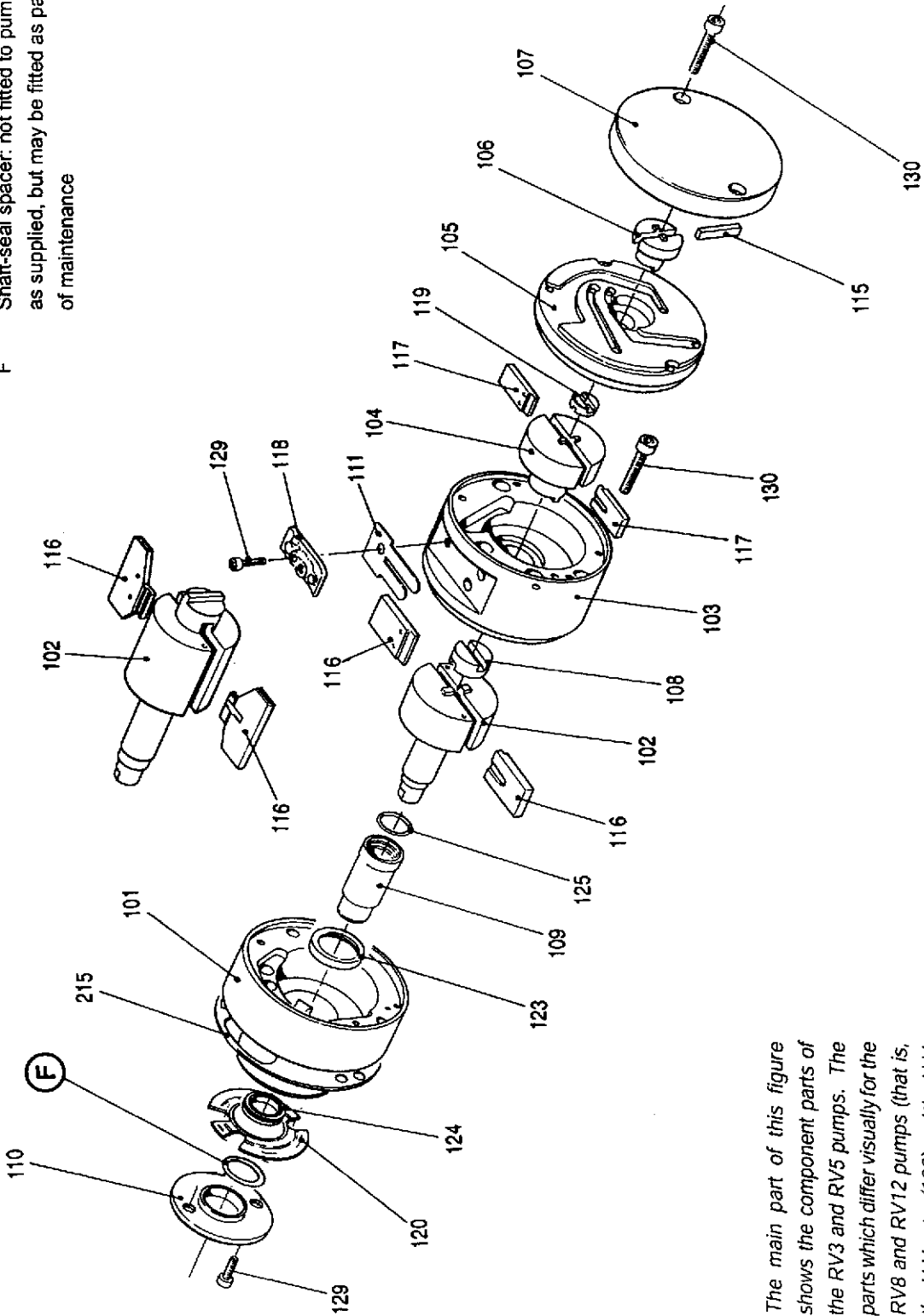

Figure 1 - Exploded view of the RV pump with 1-phase motor

F Shaft-seal spacer: not fitted to pumps as supplied, but may be fitted as part of maintenance



Note: The main part of this figure shows the component parts of the RV3 and RV5 pumps. The parts which differ visually for the RV8 and RV12 pumps (that is, the H.V. rotor (102) and the H.V. blades (116)) are shown above the main exploded view.

Figure 2 - Exploded view of the cartridge

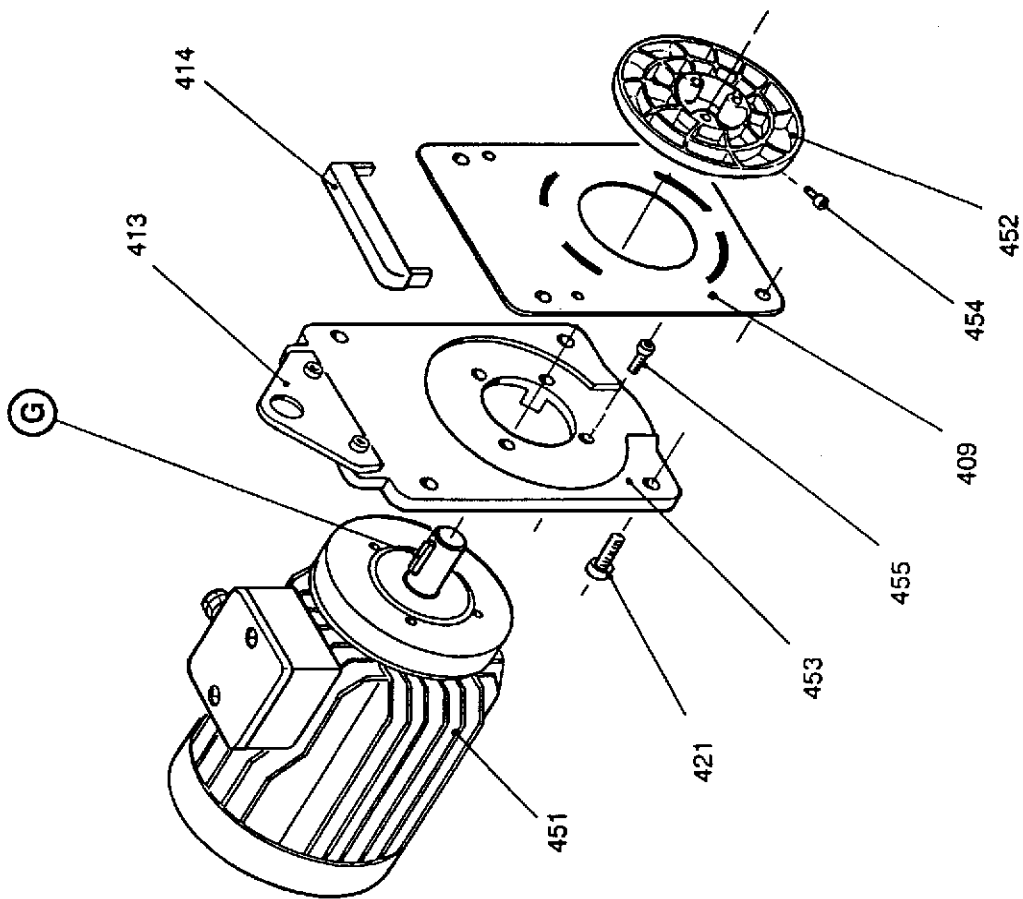

Figure 3 - Exploded view of the 3-phase motor assembly

G Key

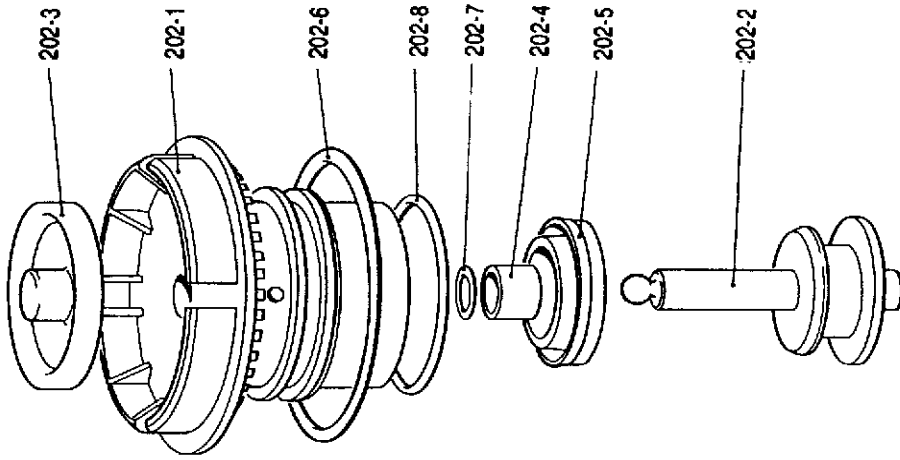

Figure 4 - Exploded view of the inlet valve assembly

Ref.	Description	Figure	Qty	Kit No.(s)	Item Number
101	HV stator	2	1	6-9	
102	HV rotor	2	1	6-9	
103	LV stator: RV3 & RV5	2	1	6-9	
104	LV rotor: RV3 & RV5	2	1	6-9	
105	Oil pump stator	2	1	6-9	
106	Oil pump rotor	2	1	6-9	
107	End plate	2	1	6-9	
108	Oldham coupling (H.V.-L.V.)	2	1	6-9	
109	Shaft-seal sleeve	2	1	6-9, 13	A652-01-027
110	Seal carrier	2	1	6-9, 12	
111	Reed valve	2	1	6-9	A652-01-029
115	Oil pump blade	2	1	2-9	
116	HV blade	2	2	2-9	
117	LV blade	2	2	2-9	
118	Reed valve clamp	2	1	6-9	A210-35-129
119	Oldham coupling (LV-oil pump)	2	1	6-9	A259-08-127
120	Printed gasket (seal carrier)	2	1	1, 6-9, 12	
123	Shaft seal (inner): 25 x 35 x 7	2	1	1, 6-9	
124	Shaft seal (outer): 20 x 30 x 7	2	1	1, 6-9, 12	
125	'O' ring: 14.6 i.d. x 2.4 section (rotor sleeve)	2	1	6-9, 13	H02122036
129	Screw: cap-head M6 x 20 (seal carrier securing)	2	3	6-9	
130	Screw: cap-head M6 x 40 (end cover securing & LV to HV securing)	2	4	6-9	
201	Air bleed assembly	1	1	1	A652-01-005
202	Inlet valve assembly	1	1	10	
202-1	Valve cover	4	1	10	
202-2	Piston	4	1	10	
202-3	Valve pad	4	1	10	
202-4	Bush	4	1	10	
202-5	'U' seal	4	1	1, 6-10	
202-6	'O' ring: 49.5 i.d. x 3.0 section	4	1	1, 6-10	
202-7	'O' ring: 7.6 i.d. x 2.4 section	4	1	1, 6-10	
202-8	'O' ring: 32.5 i.d. x 3.0 section	4	1	1, 6-10	
203	Gas ballast control assembly	1	1		A652-01-008
203-1	Gas ballast knob	1	1		
203-2	Filter	1	1		
203-3	'O' ring: 14.6 i.d. x 2.4 section (gas ballast control)	1	1	1, 6-9	
203-4	'O' ring: 21.5 i.d. x 3.0 section (gas ballast control)	1	1	1, 6-9	
204	Mode selector assembly	1	1		A652-01-009
204-3	'O' ring: 9.6 i.d. x 2.4 section (mode selector)	1	1	1, 6-9	
205	Adaptor	1	1		
208	Top plate	1	1		A210-35-125
209	Oil pressure valve	1	1	1	
210	Gas ballast check valve	1	1	1, 6-9	
211	Spring (valve pad)	1	2	1, 6-9	
212	Spring (gas ballast control)	1	1	1, 6-9	
213	Spring (inlet valve)	1	1	1, 6-10	
215	Printed gasket (cartridge)	2	1	1, 6-9	
216	Printed gasket (top plate)	1	1	1, 6-9, 10	
217	Dump valve	1	1	1, 6-9	
219	'O' ring: 57.6 i.d. x 2.4 section (cartridge)	1	1	1, 6-9	H02122055
220	'O' ring: 21.5 i.d. x 3.0 section (mode selector)	1	1	1, 6-9	
222	Shouldered washer (gas ballast)	1	1	1	
224	Screw: cap-head M6 x 20 (top plate securing)	1	4		
225	Screw: cap-head M6 x 40 (cartridge securing)	1	3		

Table 2 - Parts list

Ref.	Description	Figure	Qty	Kit No.(s)	Item Number
226	Restrictor: M6	1	1		
301	Exhaust flange assembly	1	1		A652-01-007
301-1	Exhaust flange	1	1		
301-2	Exhaust pin	1	1		
301-3	Exhaust diaphragm	1	1		
302	Inlet filter assembly	1	1		A223-05-067
306	Baseplate	1	1		
308	Coupling hub	1	1		A210-35-128
309	Reed valve baffle	1	1		A210-35-130
310	Oil box	1	1		
311	Sight-glass bezel	1	1		
312	Coupling element (motor-cartridge)	1	1	1, 6 - 9	
313	Oil filler plug	1	2		A259-08-118
314	Printed gasket (oil box)	1	1	1, 6 - 9	A271-60-005
315	Rubber foot	1	4		A265-01-041
316	Sight-glass	1	1		A292-01-018
318	Outlet cover	1	1		
319	'O' ring: 28.2 i.d. x 3.53 section (outlet flange & filler plug)	1	3	1, 6 - 9	H021-05-026
321	'O' ring: 69.5 i.d. x 3.0 section (sight-glass)	1	1	1, 6 - 9	
325	Screw: cap-head M6 x 30 (coupling securing)	1	1		
326	Screw: cap-head M6 x 20 (baffle securing)	1	*		
327	Screw: cap-head M6 x 40 (oil box securing)	1	4		
331	Outlet label	1	1		
401	Motor assembly (1-phase)	1	1	14 - 17	
403	Oil box label	1	1		
404	Oil drain-plug	1	1		A259-08-119
405	Lifting handle	1	1		A259-08-125
408	Side panel (mode selector side)	1	1		A652-01-018
409	Ducting sheet	1	1		A652-01-019
410	Fan	1	1		A223-01-007
412	Side panel (pump logo side)	1	1		A652-01-017
413	Lifting plate	1	-		
414	Lifting plate cover	1	-		
416	'O' ring: 15.6 i.d. x 2.4 section (oil drain-plug)	1	1	1, 6 - 9	H021-20-037
420	Screw: cap-head M4 x 10 (side panel securing)	1	4		
421	Screw: cap-head M6 x 20 (motor securing)	1	4		
422	Screw: cap-head M6 x 12 (lifting plate securing)	1	2		
423	Screw: cap-head M6 x 40 (fan securing)	1	1		
451	Motor assembly (3-phase)	3	1	18, 19	
452	Fan	3	1		A223-01-010
453	Motor plate	3	1		
454	Screw: cap-head M5 x 40 (fan securing)	3	1		
455	Screw: cap-head M6 x 20 (motor to motor plate securing)	3	1		
E	Motor top cover	1	1		
D	Motor starting relay (Sinpac)	1	1	11	
F	Shaft-seal spacer	2	†	1, 12	
G	3-phase motor key	3	1	18,19	

* 7 fitted to RV3 and RV5, 8 fitted to RV8 and RV12.

† Not fitted to pumps as supplied, but may be fitted as part of maintenance.

Table 2 - Parts list (continued)

2

UNPACK AND INSPECT

Remove all the packing materials and protective covers and check the components of the kit.

If any component is damaged, notify your supplier and the carrier in writing within three days; state the Item Number of the kit together with your order number and the supplier's invoice number. Retain the packing materials for inspection. Do not use the kit if it is damaged.

Check that your kit contains the components listed in Table 1, 2 or 3 as appropriate. Note that the Clean and Overhaul Kit components are packed in three separate bags, labelled bag 1, 2 and 3; the contents of the bags are shown in Table 3. If any component is missing, notify your supplier in writing within three days.

If the kit is not to be used immediately, replace the protective covers and repack the components of the kit in the packing materials. Store the kit in cool, dry conditions until required for use.

Qty	Description	Figures 1-3 reference	Check (✓)
1	Oil-pump blade	115	<input type="checkbox"/>
2	H.V. blade	116	<input type="checkbox"/>
2	L.V. blade	117	<input type="checkbox"/>

Table 1 - Checklist of Blade Kit components

Qty	Description	Figures 1-3 reference	Check (✓)
1	Inlet-valve assembly (assembled); this comprises the following components (shown in Figure 3):	202	<input type="checkbox"/>
	Valve cover	202-1	
	Piston	202-2	
	Valve pad	202-3	
	Bush	202-4	
	'U' seal	202-5	
	'O' ring: 49.5 x 3.0, nitrile	202-6	
	'O' ring: 7.6 x 2.4, viton	202-7	
	'O' ring: 32.5 x 3.0, nitrile	202-8	
1	Spring (inlet-valve)	213	<input type="checkbox"/>
1	Printed gasket (top-plate)	216	<input type="checkbox"/>

Table 2 - Checklist of Inlet-Valve Kit components

Bag label	Qty	Description	Figures 1-3 reference	Check (✓)
Bag 1	1	Shaft-seal spacer	C	<input type="checkbox"/>
	1	Reed valve	111	<input type="checkbox"/>
	1	Printed gasket (seal carrier)	120	<input type="checkbox"/>
	1	Shaft-seal (inner) †	123	<input type="checkbox"/>
	1	Shaft-seal (outer) †	124	<input type="checkbox"/>
	1	Gas ballast check-valve	210	<input type="checkbox"/>
	2	Spring (dump valve & gas ballast check-valve)	211	<input type="checkbox"/>
	1	Printed gasket (cartridge)	215	<input type="checkbox"/>
	1	Dump valve †	217	<input type="checkbox"/>
	1	Oil pressure valve	209	<input type="checkbox"/>
	1	'O' ring: 57.6 x 2.4 (cartridge/adaptor) †	219	<input type="checkbox"/>
	1	Coupling element	312	<input type="checkbox"/>
Bag 2	1	Inlet-valve 'U' seal †	202-5	<input type="checkbox"/>
	1	'O' ring: 49.5 x 3.0, nitrile (inlet-valve)	202-6	<input type="checkbox"/>
	1	'O' ring: 7.6 x 2.4 (inlet-valve) †	202-7	<input type="checkbox"/>
	1	'O' ring: 32.5 x 3.0, nitrile (inlet-valve)	202-8	<input type="checkbox"/>
	1	Spring (inlet-valve)	213	<input type="checkbox"/>
	1	Printed gasket (top-plate)	216	<input type="checkbox"/>
Bag 3	1	'O' ring: 42.5 x 3.0, nitrile (inlet connection)*	005	<input type="checkbox"/>
	1	'O' ring: 14.6 x 2.4, nitrile (gas ballast control)	203-3	<input type="checkbox"/>
	1	'O' ring: 9.6 x 2.4 (mode selector) †	204-3	<input type="checkbox"/>
	1	Spring (gas ballast control)	212	<input type="checkbox"/>
	2	'O' rings: 21.5 x 3.0, nitrile (gas ballast insert* & mode selector)	220	<input type="checkbox"/>
	1	Exhaust diaphragm †	301-3	<input type="checkbox"/>
	1	Printed gasket (oil-box)	314	<input type="checkbox"/>
	3	'O' rings: 28.2 x 3.53, nitrile (oil filler-plugs & exhaust-flange)	319	<input type="checkbox"/>
	1	'O' ring: 69.5 x 3.0, nitrile (sight-glass)	321	<input type="checkbox"/>
	1	'O' ring: 15.6 x 2.4, nitrile (oil drain-plug)	416	<input type="checkbox"/>
	1	'O' ring: 21.5 x 3.0, nitrile (gas ballast control)	203-4	<input type="checkbox"/>
	1	Shoulder washer	222	<input type="checkbox"/>
1	Inlet-valve pad ▲	202-3	<input type="checkbox"/>	

* If required

† The components (or elastomer parts of these components) will be made from viton in the Standard Clean and Overhaul Kit and from nitrile in the Nitrile Clean and Overhaul Kit.

▲ Only supplied in the Clean and Overhaul Kit (Nitrile).

Table 3 - Checklist of Clean and Overhaul Kit components

- A Oil pressure/dump valve assembly
- B Cartridge: see Figure 2
- C Gas ballast check valve assembly

- 201 Air bleed assembly
- 202 Inlet-valve assembly:
see Figure 3
- 208 Top-plate
- 226 Restrictor
- 305 Oil-box
- 327 Bolt
- 408 Side panel
- 412 Side panel
- 421 Bolt

- * Included in the Clean and Overhaul Kit: see Table 3
- † Included in the Blade Kit: see Table 1
- ◆ Included in the Inlet-Valve Kit: see Table 2
- Included for reference only: see key →

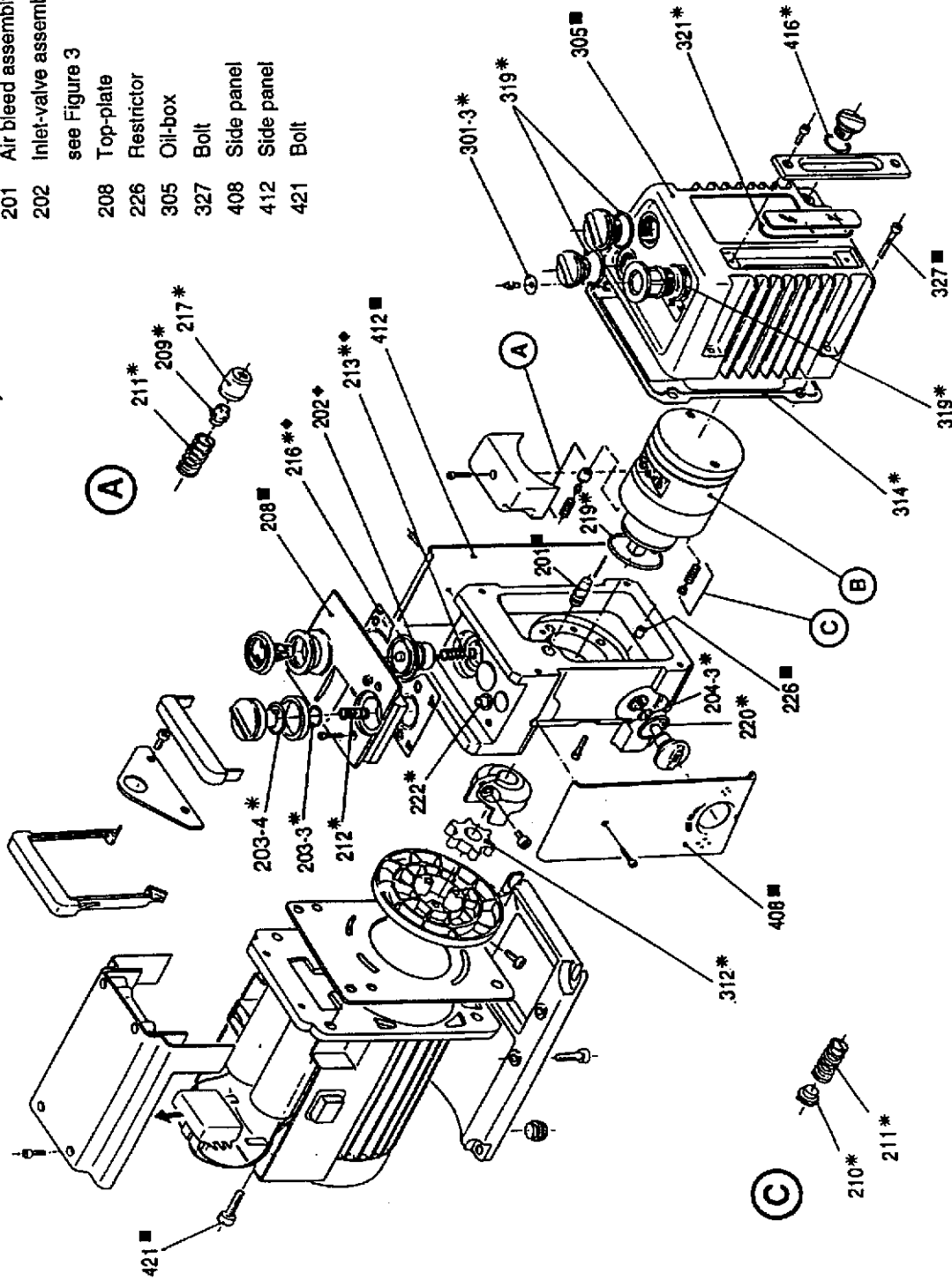
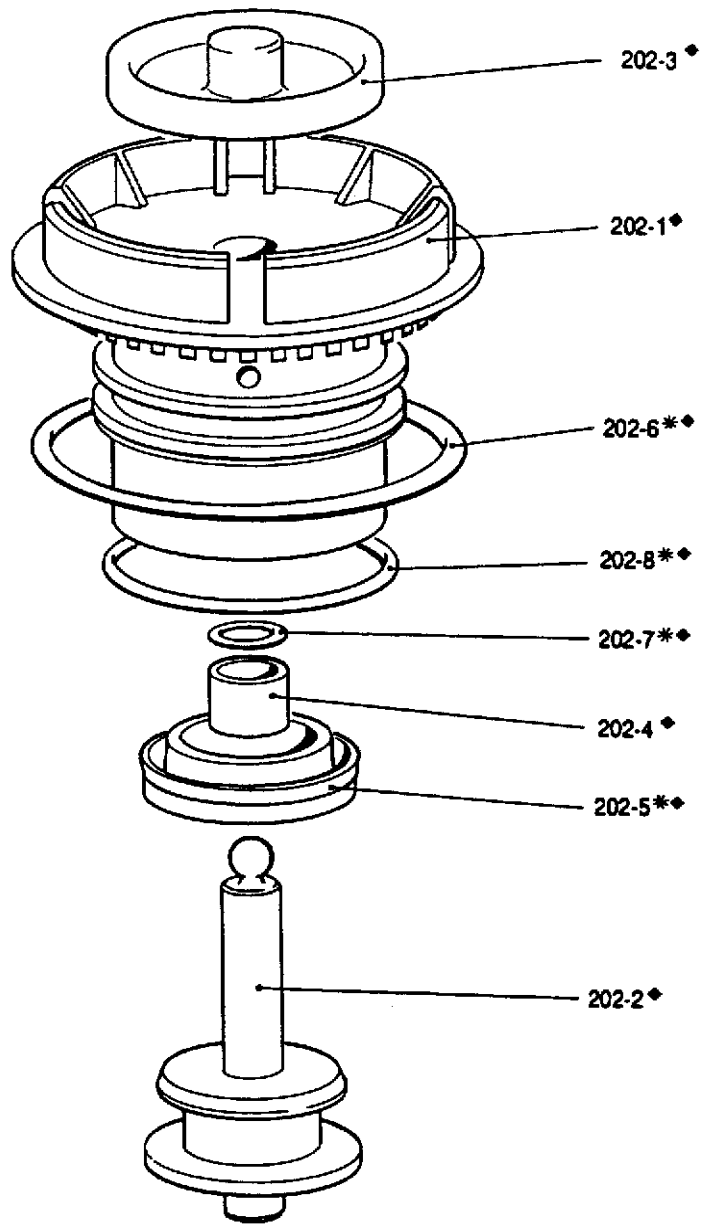

Figure 1 - Exploded view of the RV pump



- * Included in the Clean and Overhaul Kit: see Table 3
- ◆ Included in the Inlet-Valve Kit: see Table 2

Figure 3 - Exploded view of inlet-valve assembly