

ELEVATION

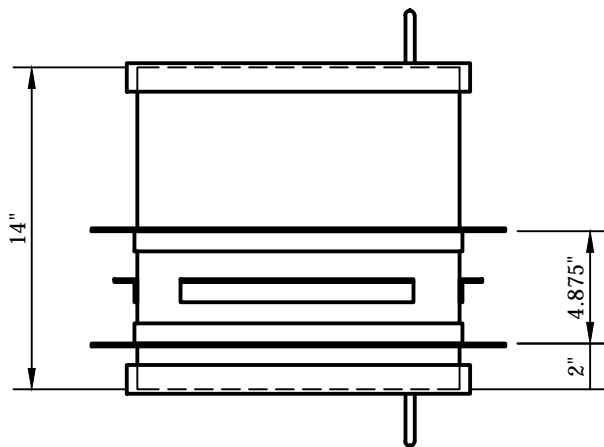

PLAN VIEW

BULLET/FIRE RESISTANT PACKAGE

PASSER

SERIES: CSE-NBP-PR-141414

MODEL NO: NFPP-3B-141414-S

1 UNIT REQUIRED

EXTERIOR DIMENSION: 14"W x 14"H x 14"D

INTERIOR DIMENSION: 13.75"W x 12.375"H x 14"D

BALLISTIC LEVEL: UL LISTED LEVEL 3

UL FIRE CLASSIFIED "B" LABEL 1-1/2 HRS

FINISH: STAINLESS STEEL

HINGE: CONTINUOUS STAINLESS STEEL

STANDARD WIRE DOOR PULL ON BOTH DOORS MECHANICAL

INTERLOCK CONTROLS DOOR OPERATION

TO REQUIRE ONE DOOR FULLY CLOSED AT ALL TIMES

WALL OPENING REQUIRED: 16"W x 15"H

APPROVAL STATUS STAMP

- Approved
- Resubmit with indicated changes
- Rejected

The undersigned being an authorized representative of the purchaser hereby accepts this drawing as indicated and assumes responsibility for the compatibility of this equipment with the projects requirements and directs Covenant Security Equipment to proceed with production of this equipment per these drawings.

By: _____

Date: _____

CIRCLE CORRECT SWING BELOW

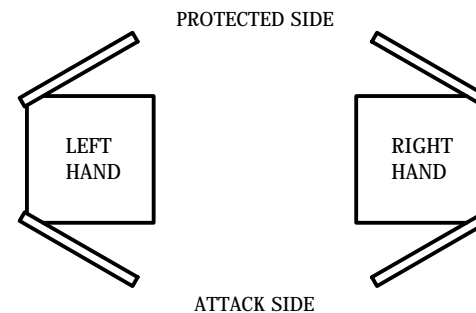

COVENANT SECURITY EQUIPMENT

DRN BY: GJ DATE: 11/11/2022



COVENANT
Security Equipment

DWG NO: CSE-NBP-PR-141414