

NOTES:

- ① ARMORTEX® BULLET RESISTANT ARMOR
- ② UNFINISHED VENEER
- ③ 16 GA. PRIME PAINTED STEEL FRAME
- ④ PARTICLE BOARD CORE
- ⑤ CONTINUOUS GEAR HINGE (NOT SHOWN)
- ⑥ HARDWARE PREPERATION AS REQUIRED (NOT SHOWN)
- ⑦ GLAZING TAPE
- ⑧ BULLET RESISTANT GLAZING
- ⑨ NEOPRENE SETTING BLOCK
- ⑩ WOOD TRIM

SHOWN)

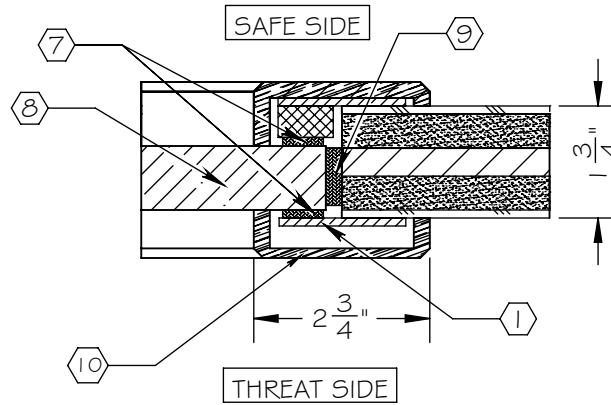
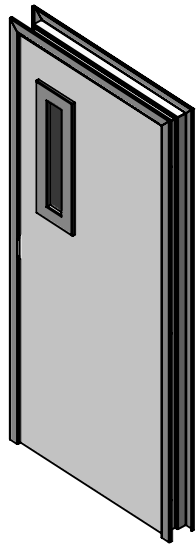

SECTION B-B
SCALE 1 : 3

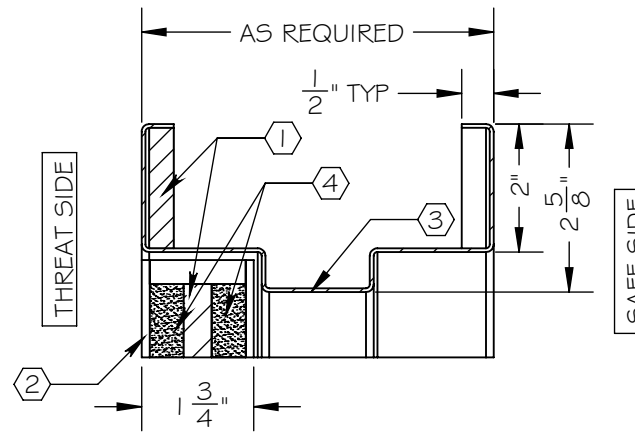

SECTION A-A
SCALE 1 : 3

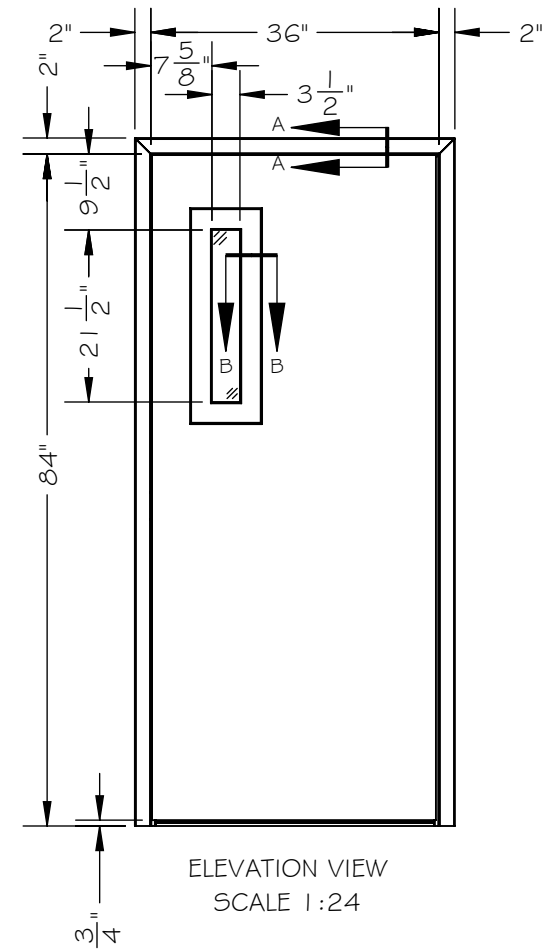

ELEVATION VIEW
SCALE 1 : 24

SCALE: AS NOTED	TITLE: WOOD SLIM LITE DOOR	UNLESS OTHERWISE SPECIFIED: DIMENSIONS ARE IN INCHES TOLERANCES: FRACTIONAL: ±1/16" ANGULAR: ±1° TWO PLACE DECIMAL ±.01 THREE PLACE DECIMAL ±.005	 COVENANT Security Equipment
DATE: 06-01-2015	MODEL: DR-WD-SL-DB		
DRAWN BY: M. FREEMAN	SHEET NUMBER: 1 OF 1		