

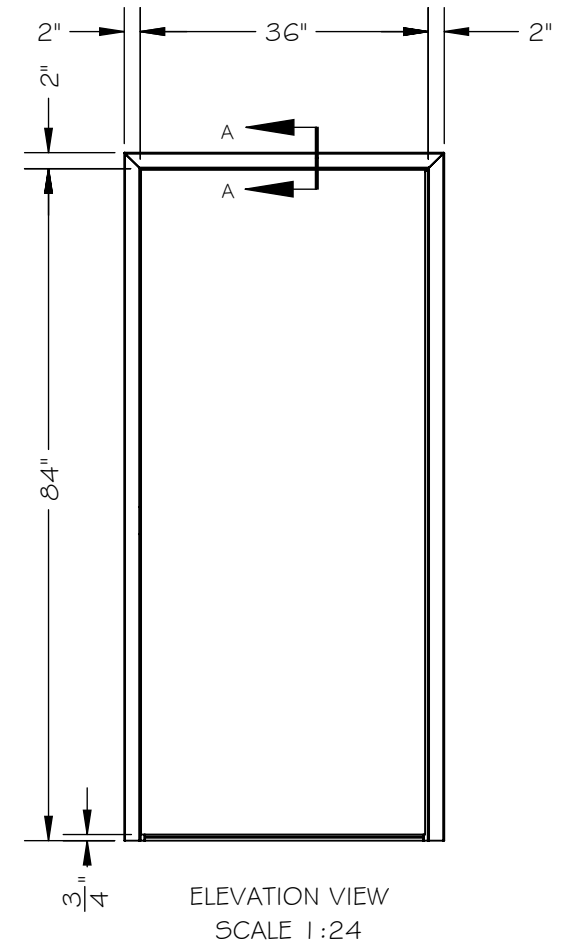

NOTES:

- ① ARMORTEX<sup>®</sup> BULLET RESISTANT ARMOR
- ② UNFINISHED VENEER
- ③ 16 GA. PRIME PAINTED STEEL FRAME
- ④ PARTICLE BOARD CORE
- ⑤ CONTINUOUS GEAR HINGE (NOT SHOWN)
- ⑥ HARDWARE PREPERATION AS REQUIRED (NOT SHOWN)

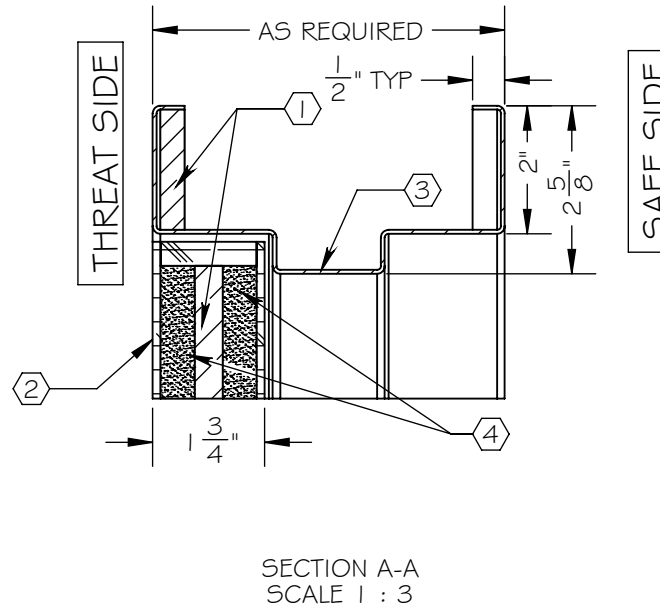
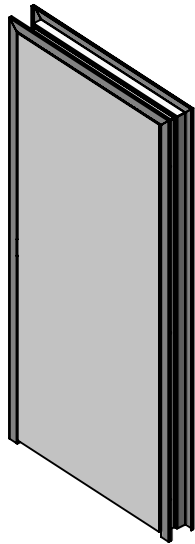

SCALE: AS NOTED	TITLE: WOOD FLUSH DOOR	UNLESS OTHERWISE SPECIFIED: DIMENSIONS ARE IN INCHES TOLERANCES: FRACTIONAL: ±1/16" ANGULAR: ±1° TWO PLACE DECIMAL ±.01 THREE PLACE DECIMAL ±.005	 <b>COVENANT</b> Security Equipment
DATE: 06-03-2015	MODEL: DR-WD-NL-DB		
DRAWN BY: M. FREEMAN	SHEET NUMBER: 1 OF 1		