

Please visit
MagicalButter.com
for the
latest
Owner's
Manual

Magical Butter.com®

Owner's Manual



Table of Contents

Overview & Features	1
Benefits	2
IMPORTANT SAFEGUARDS	2-3
Getting to Know Your MB2e	4
Technical Specifications	5
Decarb Your Botanicals	6
Cleaning Directions	6
Recipes:	
MagicalButter	7
MagicalButter Cooking Oil	8
MagicalButter Tincture	9
MagicalButterOil Concentrate (How to Reduce Alcohol Tincture to MBO)	10
Troubleshooting Guide	11
Tips & Frequently Asked Questions	12
Warranty Information	13-14
Accessories: The LoveGlove™	15
Accessories: PurifyFilters™	16
Appliance Use Disclaimer	17





At the touch of a button, enjoy great-tasting, healthy foods, or make natural skin-care products!

MagicalButter makes your recipes BOLDER!

- Brownies
- Cookies
- Smoothies
- Sauces
- Soups
- Vegetables
- Candies
- Salad dressings
- Seafood
- Marinades
- Meats
- Beverages
- Lotions & salves
- Much more

MagicalButter uses our exclusive technology to extract botanical nutrients directly into butter, cooking oil, alcohol, and lotions. Works with:

- Butter
- Alcohol
- Glycerin
- Coconut oil
- Olive oil
- Avocado oil
- Sunflower oil
- Grapeseed oil
- Peanut oil
- Much more

Features

- Fully automatic, microprocessor-controlled program sequences
- Two-button simplicity for effortless ease of use
- Pitcher constructed of stainless steel
- Integrated digital thermostat & sensors bring laboratory-grade temperature controls to your kitchen for consistent results
- Makes 2-5 cups/ 475-1180 ml per cycle
- Botanical oil in 1 hour!
- Botanical butter in 2 hours!
- Botanical tincture in 4 hours!
- Concentrated botanical oil in 5 hours!
- Recipes—let your imagination run wild!
- Self-cleaning!



Congratulations on Your New MB!

MagicalButter machines offer numerous benefits derived from years of laboratory trials and customer feedback. Research continues to reveal the numerous potential health benefits of natural botanical extracts, such as helping patients with the following conditions*:

- Cancer
- Heart disease
- High blood pressure
- Multiple sclerosis
- Sleep disorders
- Glaucoma
- Epilepsy
- HIV/AIDS
- Sexual impairment
- Obesity
- Mental health
- Countless others*

MagicalButter makes it easy to integrate botanicals into your healthy lifestyle. The possibilities are endless!*

Discover amazing recipes and fun, easy how-to videos at magicalbutter.com/recipes.

IMPORTANT SAFEGUARDS

MagicalButter.com reminds you that when using the MB machine or any electric appliance, there are some recognized, sound safety precautions that you should always follow, including:

1. **READ ALL INSTRUCTIONS** before operating appliance.
2. Do not touch hot surfaces. Use handles or knobs.
3. To protect against electrical shock, do not wet or immerse power cord, plugs, electronic components, bottom, head, handle, motor, or black plastic parts in water or other liquid.
4. Close supervision is necessary when any appliance is used by or near children.
5. Unplug from outlet when not in use and before cleaning. Allow to cool before putting on or taking off parts.
6. Do not operate any appliance with a damaged cord or plug or after appliance malfunctions or has been damaged in any manner. Return appliance to nearest authorized service facility for examination, repair, or adjustment. Use only the original cord included with the MB machine. If the cord or plug is damaged, or if the MB machine is dropped, malfunctions, or sustains any damage, **DO NOT OPERATE THE APPLIANCE**. Contact us immediately at +1 (800) 420-4334.
7. The use of any accessory attachments not specifically recommended or sold by MagicalButter.com constitutes unauthorized use and may pose a serious risk of injury. See warranty details.
8. Do not use outdoors.
9. Do not let cord hang over edge of table or counter or touch hot surfaces.
10. Do not place on or near any hot burner or in a heated oven.
11. Extreme caution must be used when moving any appliance containing hot oil or other hot liquids.
12. Always attach plug to appliance first, then plug power cord into wall outlet. To disconnect, turn any control to "off", and remove plug from wall outlet.
13. Do not use appliance for other than intended use.
14. **ALWAYS USE EXCLUSIVELY IN A WELL-VENTILATED AREA.**

2

* MagicalButter products are NOT medical devices in any way. No statement made about MB products has been evaluated by the U.S. Food and Drug Administration. MB products are not intended to diagnose, treat, cure, or prevent any disease [U.S. 21 C.F.R. 101.93(c)].

Balancing Nature & Technology™



Important Safeguards Continued

15. Keep the machine away from sparks or flames, and never ignite a fire inside the pitcher.
16. **THE MB MACHINE AND ITS CONTENTS WILL BE HOT DURING AND AFTER USE. TAKE ALL REASONABLE PRECAUTIONS AGAINST BEING BURNED.**
17. Skipping or skimming these important safeguards is not the same as actually reading them. Those who most urgently need that message just missed it. But not you! Congratulations on putting safety first!
18. No appliance, including the MB machine, should be used by or near unsupervised children.
19. **ALWAYS UNPLUG THE ELECTRIC CORD** from the outlet when the MB machine is not in use, before putting on or taking off parts, and after cleaning.
20. **AVOID ANY CONTACT WITH MOVING PARTS. KEEP ALL HANDS, FINGERS, and UTENSILS OUT** of the MB machine when it is ON.
21. Be aware that the interior blades of the MB machine are extremely sharp and that you must handle them carefully—especially when assembling, disassembling, or cleaning the MB machine.
22. Do not use the MB machine if any part is broken, chipped, or cracked; or if the blending blades are broken, cracked, or loose.
23. **NEVER PLACE THE PURIFYFILTER™ BAG INSIDE THE MB MACHINE. THE BLADES WILL DESTROY THE FILTER, AND THE FILTER WILL DAMAGE THE BLADES.** The filter is used only AFTER the machine has completed its cooking cycle. The filter is NEVER to be used in the machine.
24. Using the MB machine for anything other than its intended purpose constitutes unauthorized use and may pose a serious risk of injury. See warranty details.
25. **ALWAYS OPERATE THE MB MACHINE WITH THE HEAD SECURELY SEATED ON THE PITCHER (LID CLOSED).** INJURY CAN RESULT if moving blades accidentally become exposed.
26. **DO NOT UNDERFILL** (below the MIN line) **OR OVERFILL** (above the MAX line) the pitcher.
27. **DO NOT LEAVE THE MB MACHINE UNATTENDED WHILE PLUGGED IN OR OPERATING.**
28. A SHORT POWER SUPPLY CORD IS PROVIDED TO REDUCE THE RISK RESULTING FROM BECOMING ENTANGLED IN OR TRIPPING OVER A LONGER CORD.
29. EXERCISE CAUTION IF USING AN AVAILABLE EXTENSION CORD: (a) ENSURE THAT THE MARKED ELECTRICAL RATING OF THE EXTENSION CORD IS AT LEAST AS GREAT AS THE ELECTRICAL RATING OF THE APPLIANCE, AND (b) ARRANGE THE LENGTHENED CORD SO THAT IT WILL NOT DRAPE OVER THE COUNTER OR TABLETOP, WHERE IT COULD BE PULLED BY CHILDREN OR TRIPPED OVER UNINTENTIONALLY.
30. MagicalButter products are NOT medical devices in any way. No statement made about MB products has been evaluated by the U.S. Food and Drug Administration. MB products are not intended to diagnose, treat, cure, or prevent any disease [U.S. 21 C.F.R. 101.93(c)].
31. **SAVE THESE INSTRUCTIONS.**

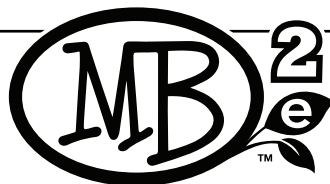

Getting to Know Your MB Machine

1. Head: contains motor and microprocessor*
2. Head handle*
3. *Temperature button**: No Heat, 130°F/54°C, 160°F/71°C, 190°F/88°C, and 220°F/104°C (select 130°F/54°C if using machine at high altitude and/or in dry climate)
4. *Timer buttons**: 1 Hour/Oil, 2 Hours/Butter, 4 Hours/Tincture, 8 Hours, and CLEAN
5. Pitcher handle*
6. Plug*: insert into base before attempting to start MB machine
7. Heating element*
8. Pitcher: constructed of high-quality stainless steel
9. Proprietary immersion blade: chops, grinds, and stirs ingredients
10. Overflow sensor: prevents ingredients from bubbling out of pitcher
11. Digital thermostat: provides maximum control of temperature
12. Motor: household type



*** IMPORTANT: DO NOT
IMMERSE, WET, OR WASH Nos.
1-7 WITH WATER.
USE DAMP CLOTH ONLY.**



Technical Specifications

Capacity: 2-5 cups/

475-1180 ml

Weight: 8.00 lb/3.63 kg

Height: 12 1/2 in/31.75 cm

Width: 9 1/2 in/24.13 cm

Voltage: 110V (USA/CANADA model)

220V-230V (UK model)

220V-240V (EU model)

240V (AU/NZ model)

Frequency: 50 Hz

Motor: household type

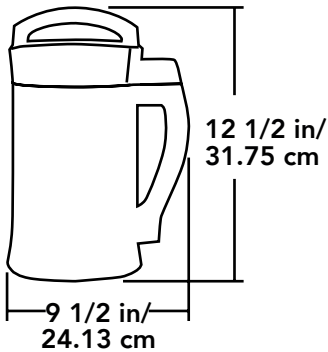
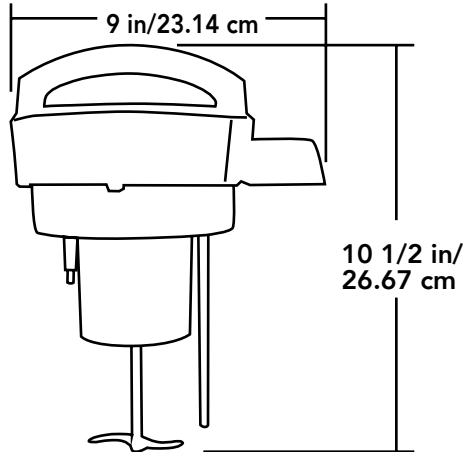

5 cups/
1180 ml

MAX

2 cups/
475 ml

MIN

9 3/4 in/
24.76 cm

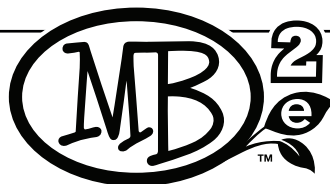
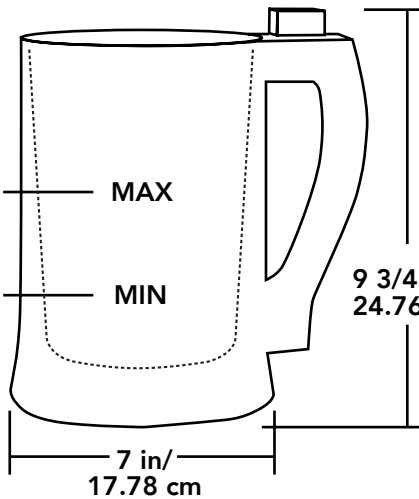

How To

Decarboxylate Your Botanicals

Important:

Decarboxylation is only for specific, rare blossoms and herbs. Do not use with common, commercially available culinary herbs, fruits, and flowers, as it will remove their moisture and flavor.

How to:

1. Preheat your oven to 250°F/120°C.
2. Place your botanicals into a roasting bag or covered baking dish.
3. Bake on the center oven rack for 30 minutes.
4. When time is up, remove the sample from the oven, and let it cool completely; to speed up the process, place it in the freezer. This step is critical for preserving certain phytonutrients.
5. Once your botanicals are completely cooled, you are ready to run any desired cycle in your MagicalButter machine.

Directions for Car-Wash Clean Function

What is car-wash clean?

Might need a quick rinse and towel dry.

1. Rinse pitcher and blades. **Do not wet or immerse any electrical or black plastic parts.**
2. Fill halfway between MIN and MAX lines with water.
3. Add dish soap roughly the size of a coin.
4. Secure lid, and press *Clean* button. For best results, clean immediately after use.

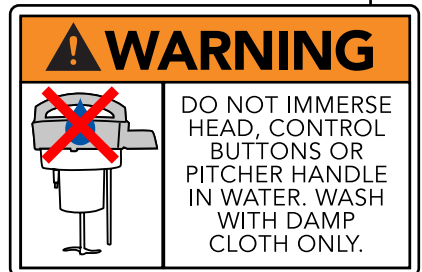



Base Recipe

MagicalButter

Skill level: Easy

Cycle time: 2 hours

Yield: Approximately 2-5 cups/475-1180 ml

Ingredients:

- ¼-½ ounce/7-14 g botanicals per cup/240 ml*
- 2-5 cups/475-1180 ml unsalted butter, softened; for best results, **clarified****
- 1 tablespoon/15 ml lecithin per cup/240 ml***

Important: Do not use margarine or water

2 cups minimum to 5 cups maximum ingredient capacity

How to:

1. Place the ingredients into your MagicalButter machine, and secure the head.*
2. Press the *Temperature* button, and select 160°F/71°C; then press the *2 Hours/Butter* button.
3. After the cycle is complete, unplug the unit at the outlet, and remove the head of the appliance. Put on your LoveGlove™, and pour the pitcher contents slowly through your PurifyFilter™ into formed molds or other storage container.

Chef's Notes:

*For best results do not pre-grind botanicals. Adjust botanical weight according to your personal preference.

** For optimal extractions and maximum potency, based on extensive kitchen trials, our chef now recommends clarifying your butter before adding it to the pitcher. To clarify, gently melt and simmer the butter, discard the milk solids and surface foam, and retain the clear golden liquified butterfat. To clarify further, you can skip clarifying and simply use melted or softened butter. Do not use cold, firm butter.

Lecithin

*** Sunflower, rice, or soy lecithin is optional but highly recommended. Lecithin is an emulsifier used in cooking and in the pharmaceutical industry for binding ingredients in lipids (butter, oils, and fats). It helps to increase the bioavailability of plant compounds in your high-lipid infusions, intensifying the potency of the resulting extracts. Lecithin is available at your local health-food or vitamin store in the form of granules, powder, or liquid. Avoid capsules; they contain too many binders and fillers. If you use liquid, use only 1 teaspoon/5 ml per cup/240 ml.



Base Recipe

MagicalButter Cooking Oil

Skill level: Easy

Cycle time: 1 hour

Yield: 2-5 cups/475-1180 ml

Ingredients:

- ¼-½ ounce/7-14 g botanicals* *per cup/240 ml*
- 2-5 cups/475-1180 ml cooking oil (*preferably coconut oil, or use olive, grapeseed, sunflower, almond, walnut, sesame, avocado, macadamia, or peanut oil; NOT recommended are ordinary soybean, canola, extra virgin olive, and corn oil*)
- 1 tablespoon/15 ml lecithin** *per cup/240 ml*

Important: 2 cups minimum to 5 cups maximum ingredient capacity

How to:

1. Place the ingredients into your MagicalButter machine, and secure the head.
2. Press the *Temperature* button, and select 160°F/71°C; then press the *1 Hour/Oil* button.
3. After the cycle is complete, unplug the unit at the outlet, and remove the head of the appliance. Put on your LoveGlove™, and pour the pitcher contents slowly through your PurifyFilter™ into a dark glass container.

Chef's Notes:

Do not add water.

*For best results do not pre-grind botanicals. Adjust botanical weight according to your personal preference.

***See lecithin information on page 7.





Base Recipe

MagicalButter Tincture

Skill level: Easy

Cycle time: 4-8 hours

Yield: 2-5 cups/475-1180 ml

Ingredients:

- ¼-1 ounce/7-28 g botanicals per cup/240 ml*
- 2-5 cups/475-1180 ml Everclear grain alcohol, 151 or 190 proof (or vegetable glycerin)

Important: 2 cups minimum to 5 cups maximum ingredient capacity

CAUTION: MATERIALS ARE HIGHLY FLAMMABLE.

Could cause injury. Never use an open flame, natural gas or propane burner, or permit smoking around the cooking process.

How to:

1. Place the ingredients into your MagicalButter machine, and secure the head.
2. Press the *Temperature* button, and select 130°F/55°C; then press the *4 Hours/Tincture* or *8 Hours* button (8-hour tincture will have a stronger flavor and deeper intensity).
3. After the cycle is complete, unplug the unit at the outlet, and remove the head of the appliance. Put on your LoveGlove™, and pour the pitcher contents slowly through your PurifyFilter™ into a dark glass container.

Chef's Notes:

Do not add water or lecithin.

*For best results, do not pre-grind botanicals. Adjust botanical weight according to personal preference.

Refrigerate or store your MagicalButter Tincture in a cool, dry place. Properly stored, alcohol tinctures may keep indefinitely.



Base Recipe

MagicalButterOil Concentrate

(How to Reduce Alcohol Tincture to MBO - No MB Machine Required)
DO NOT REDUCE OIL OR GLYCERIN TINCTURE - RECIPE USES ALCOHOL TINCTURE ONLY

Skill level: Moderate

Cook time: Approximately 30 minutes per cup

Yield: Approximately 1-2 teaspoons per cup/5-10 ml per 240 ml

Important:

Reducing herbal tincture to MBO is possible only with specific, rare blossoms and herbs. Do not use with common, commercially available culinary herbs, fruits, and flowers.

CAUTION: MATERIALS ARE HIGHLY FLAMMABLE.

Could cause injury. Never use an open flame, natural gas or propane burner, or permit smoking around the cooking process.

Ingredient:

1-5 cups/240-1180 ml MagicalButter Tincture

How to:

1. Transfer your tincture into a non-stick saucepan.
2. Place the saucepan on an electrical or induction plate on low heat, and bring it to a slow boil. Continue simmering for approximately 30 minutes per cup/240 ml. Continually stir oil from sides to bottom of the saucepan. When the consistency reaches that of warm maple syrup, you have produced MBO.
3. Remove your MagicalButterOil Concentrate from heat, and allow it to cool 1 minute before pouring it into a dark glass container.

Chef's Notes:

- Patience is essential—cooking time may vary based on variety of factors.
- MBO will be very sticky. Use clean, non-stick silicone utensils.





Troubleshooting Guide

Situation	Cause	Solutions
Machine will not start, makes continuous beeping sound	Not enough liquid inside pitcher	Be sure level of contents is between MIN and MAX lines
	Dirty overflow sensor*	Clean overflow sensor*
	<i>Temperature</i> not selected before <i>Cycle Time</i>	First select <i>Temperature</i> ; then select <i>Cycle Time</i>
Blender motor not functioning	Blender motor starts once extraction temperature is reached	Wait about 15 minutes into cooking cycle for blending to begin
	Pitcher filled under MIN line or above MAX line	Use correct amount of ingredients per owner's manual
Spillover	Level of liquid is above MAX line	Be sure level of contents is below MAX line
	Too much soap added during <i>Clean</i> cycle	Reduce amount of soap used during <i>Clean</i> cycle
Other issues	Contact us at: MagicalButter.com	Contact us at: MagicalButter.com

*See page 4, item 10

Tips & Frequently Asked Questions

What is the purpose of the LED lights, and what do they tell me?

Aside from providing ambiance and a colorful light show in your kitchen, the integrated LED display encircling the top of your MagicalButter appliance has an important functional purpose: informing you of the machine's operating status. The lights are strategically positioned to reflect off the ceiling during operation. As the device is exceptionally quiet when not blending or stirring, the LED display constantly and silently indicates that the cooking cycle is proceeding. The lights automatically shut off, and the unit beeps, to notify you when the cycle is completed.

What does each button do?

Each button runs a preset, microprocessor-controlled cycle: grinding, heating, extracting, and stirring. To intensify your results, simply extend your extraction time by selecting a longer cycle. The standard cycle time for oil is 1 hour, for butter 2 hours, and for tincture 4 or 8 hours. The *Clean* function has a run time of about 3 minutes.

How do I use the self-cleaning function?

First, unplug the electrical cord from the machine. Then fill the pitcher with water to a level halfway between the MIN and MAX lines. Add dish soap about the size of a coin. Secure the head, plug the power cord back in, and press the *Clean* button. After the cycle has completed, disconnect the cord from the appliance, and carefully rinse the remaining soap from the interior of the pitcher. **NOTE: DO NOT IMMERSE, WET, OR WASH WITH WATER ANY BLACK-COLORED PARTS OF THE MACHINE. USE DAMP CLOTH ONLY.**

How do I clean the PurifyFilter™?

Remove all debris from the filter. Rinse it thoroughly, flip it inside out, and rinse again. Fill a bowl with hot water and some dish soap, and soak the filter for about 10-15 minutes. Give it a final rinse, and drip dry in your dish rack. DO NOT wash the PurifyFilter™ in the dishwasher or washing machine.

For more tips and up-to-date information, please visit MagicalButter.com.

Customer Service

If you have a question about your MB machine, please call our toll-free customer service number, +1 (800) 420-4334. Please have the model, type, and series of your MB machine handy for your TeamMB representative to help you more efficiently.



Limited One-Year Warranty, Part I

IMPORTANT NOTE: Please be aware that eBay.com has no relationship with our company and is NOT AN AUTHORIZED RESELLER. Products sold on this site are likely illegally diverted and therefore may be refurbished, reconditioned, demonstration models, or counterfeit. Products sold on these sites are likely illegally diverted and therefore may be refurbished, reconditioned, demonstration models, or counterfeit. Such products may be unsafe to use or fail to perform as anticipated. Thus our LIMITED WARRANTY is expressly NULL AND VOID if purchase is made through eBay.com. This policy is to ensure customers get our quality product, excellent customer service, and warranty support.

The MB machine included with this LIMITED WARRANTY is warranted to be free from defects in material and workmanship for a period of ONE (1) year from the date of original purchase, except as noted below. During this period, we will repair or replace this product, at our option, at no cost. THE FOREGOING WARRANTY IS IN LIEU OF ANY OTHER WARRANTY, WHETHER EXPRESSED OR IMPLIED, WRITTEN OR ORAL, INCLUDING ANY WARRANTY OF MERCHANTABILITY OR FITNESS FOR A PARTICULAR PURPOSE. ANY LIABILITY IS EXPRESSLY LIMITED TO AN AMOUNT EQUAL TO THE PURCHASE PRICE PAID, AND ALL CLAIMS FOR SPECIAL, INCIDENTAL AND CONSEQUENTIAL DAMAGES ARE HEREBY EXCLUDED. There is no warranty with respect to the following, which may be supplied with this product: plastic parts, strainer, blades, and/or agitators.

This warranty extends ONLY TO THE ORIGINAL CONSUMER PURCHASER and PROVIDED THE PRODUCT WAS PURCHASED FROM THE MANUFACTURER OR AN AUTHORIZED RESELLER, and does not cover a defect resulting from abuse, misuse, neglect, use for commercial purposes, repairs by unauthorized personnel, any use not in conformity with the printed directions, or other causes not arising out of defects in manufacturer's materials or workmanship.

This LIMITED WARRANTY gives you, the ORIGINAL CONSUMER PURCHASER FROM THE MANUFACTURER OR AUTHORIZED RESELLER, specific legal rights, and you may also have other legal rights which vary from state to state, or province to province. Some states or provinces do not allow limitations on implied warranties or special, incidental or consequential damages, so the foregoing limitations may not apply to you.

This warranty does NOT extend to units that have been: altered or modified; used in a manner inconsistent with written instructions in this manual; or used in violation of any state or federal laws. It also does NOT extend to damaged products or parts that have had the serial number removed, altered, defaced, or rendered illegible.



Limited One-Year Warranty, Part II

THE ORIGINAL CONSUMER PURCHASER FROM THE MANUFACTURER OR AUTHORIZED RESELLER will be responsible for shipping costs. MagicalButter.com will pay for return shipping to the customer. The warranty does not cover damage during your shipping to the service location. Please ensure that proper precautions are taken.

If you have a claim under this warranty, please contact us at +1 (800) 420-4334, or e-mail support@MagicalButter.com.

What happens in the unlikely event of an operating problem with the MB machine?

Please call us at +1 (800) 420-4334, or e-mail us at support@MagicalButter.com. We may be able to troubleshoot it quickly over the phone or online and get everything working correctly. If we're unable to resolve the issue to your satisfaction, we'll ask you to send the machine back to us, including all parts, via a tracked shipping agent (e.g., FedEx or UPS). All shipping costs are your responsibility except as noted below.

Should the MB machine have a defect in material or construction quality that is brought to our attention in the first sixty (60) days, we will provide you with a prepaid shipping label for sending the unit to us. **You MUST have proof of purchase.** We will then repair or replace the product (at our sole discretion) and ship it back to you at no cost.

If a defect in material or construction quality is brought to our attention after sixty (60) days but within one (1) year of purchase, we will repair or replace the product (at our sole discretion) and ship it back to you at no cost. **You MUST have proof of purchase.**

If a defect in material or construction quality is brought to our attention after one (1) year; or in any circumstance wherein we determine that it was caused by operator error or misuse, whether or not accidental (e.g., wetting the electronic components, dropping the machine, using it to make glue), we will contact you with an estimate for repairing the product and shipping it to you. You will then have the opportunity to provide payment information to be later used for those costs, or you may receive a discounted credit for any potentially reclaimable part(s).

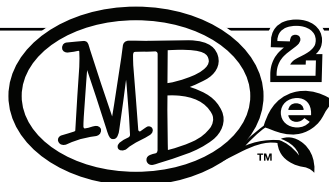



Accessories



Comprised of premium-quality silicone, the LoveGlove™ is designed to protect both the freshly prepared extract and the user's hand during the filtering process. By preventing the hot contents of the pitcher from coming into contact with the hand holding the PurifyFilter bag, the LoveGlove provides for safe and sanitary straining.



Accessories



PurifyFilter™ bags are invaluable components of the MagicalButter cooking team. Constructed of extremely durable, top-quality nylon, these filters are specifically designed to allow optimal liquid flow and sediment retention. Teamed with the LoveGlove™, PurifyFilters make straining your extractions a breeze.

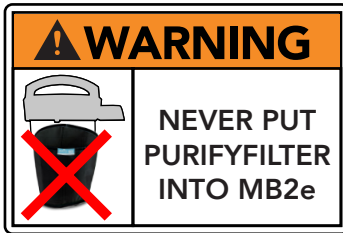



Appliance Use Disclaimer

THIS APPLIANCE IS TO BE USED ONLY IN A WELL-VENTILATED AREA AND AWAY FROM ANY FLAME OR IGNITION SOURCE. FATS, ALCOHOL, AND THE VAPORS FROM ALCOHOL TINCTURE PREPARATION ARE HIGHLY FLAMMABLE. MAGICALBUTTER.COM®, PBC HEREBY EXPRESSLY DISAVOWS ANY AND ALL LIABILITY IN USING THE MB MACHINE. ALL CLAIMS FOR SPECIAL, INCIDENTAL, AND CONSEQUENTIAL DAMAGES ARE HEREBY EXCLUDED. AVOID ANY CONTACT WITH MOVING PARTS. ALWAYS KEEP HANDS, FINGERS, AND UTENSILS OUT OF THE MB MACHINE WHEN IT IS SWITCHED ON. OPERATE THE MB MACHINE ONLY WITH THE HEAD SECURED ON THE PITCHER (LID CLOSED). DO NOT UNDER- OR OVERFILL THE MB PITCHER. DO NOT LEAVE THE MACHINE UNATTENDED WHEN PLUGGED IN OR OPERATING. THIS APPLIANCE IS INTENDED FOR HOUSEHOLD USE ONLY.

Find recipes and watch how-to videos at:
magicalbutter.com/recipes





We value your feedback & opinions.

Questions & Comments?

E-mail: support@MagicalButter.com • Telephone +1 (800) 420-4334
Copyright © 2016 MagicalButter.com, PBC (Public Benefit Corporation).
All domestic and international rights reserved. Patent pending.
Designed in Florida (USA). Assembled in China.

MagicalButter.com, MB2e, Eat To Treat, ScentLock Lid, Machine Cooking Certified, PurifyFilters, The LoveGlove, TeamMB, and Balancing Nature & Technology are claimed, reserved, and/or registered trademarks of MagicalButter.com, PBC.

