

Waterproof Camera Case

FOR—Panasonic GH5

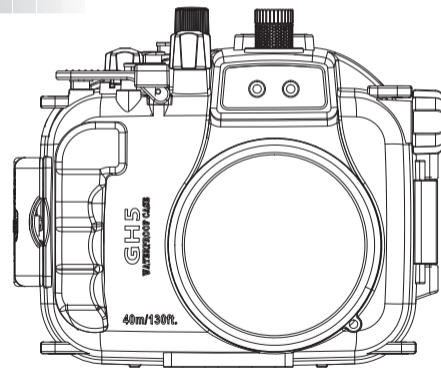

User Manual



Contents

Introduction	P02
Safety precautions.....	P03
Package contents.....	P04
Names of parts.....	P05
Data cable installation.....	P06
O-ring and silicone grease.....	P07
Preparation of camera.....	P08
Use of the case.....	P09
Maintenance.....	P10
Storage.....	P11
Specification.....	P12

Introduction

- Please read user manual carefully before use.
- Please keep user manual for future reference.
- Please use waterproof case when fully understand the contents of the user manual.
- Company does not assume any other liability arising from incorrect operation. Including but not limited to occasional or consequent of the damage or is the loss of profits or due to the use or failure to use the product cause work to stop or damage, etc.

■ Safety precautions

- ※ When using waterproof case underwater, please pay attention to your current situation to avoid accident or injury.
- ※ When locating the waterproof case in a big temperature difference areas in a short time will cause condensation on the inner surface of the case (small water droplets)
If condensation occurs, remove the camera from the waterproof case and wipe off it with soft cloth and the beads. Please use after the water vapor is completely evaporated.
- ※ Do not damage the waterproof o-ring, scratch its surfaces or allow hair, sand, dirt and other debris to accumulate between the waterproof o-ring and the case. This may cause an accident.
- ※ Do not use the waterproof case at temperature below 0°C ,higher than 40°C or underwater depth exceeding 40 meters.
- ※ Do not put waterproof case in hot, wet place or direct sunshine for a long time.
- ※ If leakage, stop using waterproof case immediately. Separate water and take out the camera in case of damage.

■ Package contents

- | | |
|---------------------|---------------------------|
| Waterproof case (1) | Lens protective cover (1) |
| O-ring (1) | Dust-free cloth (1) |
| Wrist strip (1) | User manual (1) |
| Neck strip (1) | |
- >> Optional accessories: Silicone grease

Please confirm that all the package accessories are complete when purchase.
If there is any omission, please contact the dealer or manufacturer timely.

■ Name of Part

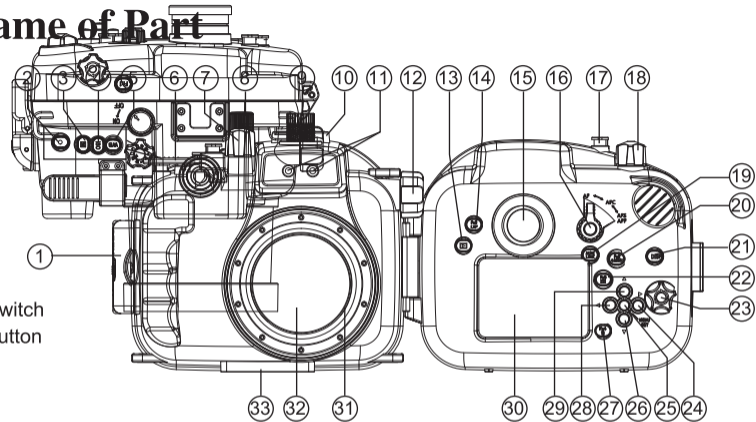

- | | | | |
|----------------------------|-------------------|--------------------------|---------------------------|
| 1、Hinge Switch | 13、 | 20、Fn2/QMENU | 27、Fn4 |
| 2、Video Button | 14、Fn5 LVF | 21、DISP | 28、Control Panel / Left |
| 3、 | 15、Viewfinder | 22、Fn3 | 29、Control Panel / UP |
| 4、ISO | 16、AF/AFC/AFS/AFF | 23、Adjust Dial | 30、Display Window |
| 5、WB | 17、FN1 | 24、Control Panel / Right | 31、Thread Interface(67mm) |
| 6、Shutter Button | 18、Adjust Dial | 25、MENU SET | 32、Removable Lens Ports |
| 7、Shooting Mode | 19、AF/AE LOCK | 26、Control Panel / Down | 33、Bracket Hole |
| 8、ON / OFF | | | |
| 9、External Data Connection | | | |
| 10、Hot Shoe | | | |
| 11、Optical Fiber Connector | | | |
| 12、Optional Mode Dial | | | |

■ Data cable installation

- ① Connect data cable plug in waterproof housing to the camera hot shoe mount and cover the housing.
- ② Connect the flash data cable to the mount of the waterproof housing.

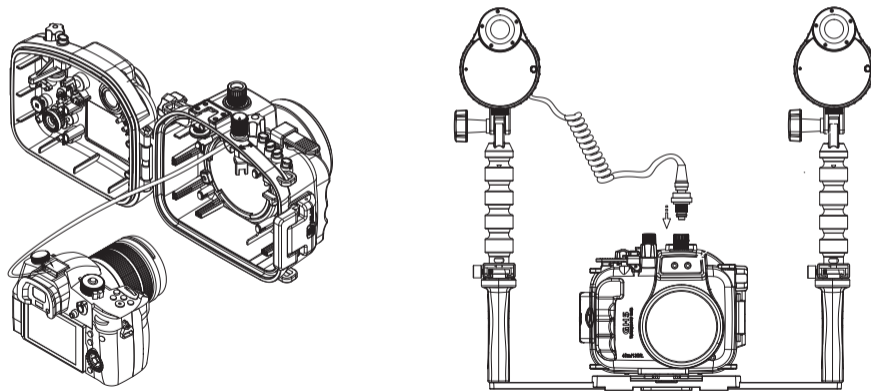

■ O-ring and silicone grease

The waterproof case use o-ring to maintain waterproof function. It's important to maintain o-ring. Improper use of maintenance and installation will case leakage.

1. Remove o-ring with finger. Do not use fingernails or sharp metallic objects.
2. Make sure there is no dirt,sand,hair,dust,salt and thread etc. If have, please use soft cloth to clean it. Use fingertips to gently wipe around the o-ring to see if there are invisible dirt. After wiping, be careful do not leave any fabric fibers on the o-ring. Check whether have cracks, twist, deformation, fine cracking, scratches, sand and others on the o-ring. If have, replace the new o-ring.
3. Check the o-ring mounting groove and make sure there is no debris in it.
4. Apply grease on o-ring. Drop a drop grease on your index finger, hold the o-ring between your index finger and thumb and slide your finger around the o-ring to applied it evenly. Grease has function of protection and prevent damage.
5. Put o-ring on fix mounting groove and make sure o-ring has no dirt, no twist and no raised. Do not pull the o-ring by hand.
6. Before install the camera, please close the waterproof case and put it into the water to check there is no leakage.
7. The o-ring's service life varies depending on the frequency and storage conditions of the waterproof case. Generally speaking, it is about one year. If o-ring is cracked or damaged, should replace a new o-ring. After replacement, please check leakage.

■ Preparation works

Adjust camera specification and ensure record video or picture has natural color. Before use the camera under sea, please ensure that your important picture and file has been transferred to the computer.

1. Install a fully charged battery, insert the memory card and make sure the memory card has enough room to record the image.
2. Remove the wristband from your camera.
3. Install camera compatible lens.
4. Turn on the camera and set the required parameters in advance.
5. Turn off the camera and put it into the waterproof case.
6. Close the waterproof case and secure the safety lock.(Note: do not clamp anything, such as a wristband, strap or hair on a waterproof case. It will cause leakage.)
7. Repeat press the case's buttons and dials to make sure the camera can work well.

Use waterproof case

Before put camera into the waterproof case and use in the sea, please put the case into water about 1 meter first and ensure that the case can work well and no leakage. About more information about camera function, please check the user manual.

1. Press ON/OFF button to turn on the power.
2. Hold the camera in both hands and press the shutter button to shoot the image. The movie will not be able to record audio.
3. Before open the case, please use fresh water to clean and wipe it with soft dry cloth. Press ON/OFF button to turn off power. Open the safety lock and remove the camera. When you open the case, don't spill the body, hair and diving suit's water on the camera.

Maintenance

- After use, fasten waterproof case button, clean it with fresh water in order to clean the salt and sand. Wipe it with soft dry cloth. Suggest you close the waterproof case and keep it in fresh water about 30 minutes. If there is salt stay in waterproof case, it will damage or rust metal parts and cause leakage.
- Clean the inside of the waterproof case with soft dry cloth. Do not wipe with water.
- Perform the maintenance work after each use of waterproof case.
- Do not use any type of solvent (such as alcohol, gasoline or other thinner) to clean, it may damage the waterproof case.
- If the o-ring seal is too dry, remove it with your finger pulp. Do not use nails or sharp object to remove. When the seal is removed, drop a drop of grease on your index finger and place the seal in the middle of your index finger and thumb. Apply the grease on the o-ring seal evenly, then insert the seal into the fixed groove and store the case in a ventilated place.
- Avoid placing waterproof case in cold, hot and humid places.

Storage

- Keep the waterproof case open when storing it. This will prevent the waterproof o-ring seal from deforming, thus can ensure the waterproof function.
- Do not store the waterproof case in hot, cold, humid place or near naphthalene chemical and pesticide.
- Do not store the waterproof o-ring seal in a place where can accumulate dust and easy scratched.
- If you do not plan to use the waterproof case for over a month, remove the waterproof o-ring seal and wipe off the grease. Hold the seal between your index finger and thumb and slide your fingers around the seal. Place it in a clean plastic bag.

Specification

Waterproof depth: 40m (130ft)

Compatibal for: 12-60mm/45-150mm

Waterproof element: O-ring seal

Main material: PC, Optical glass, stainless steel, EPDM rubber

Dimension: 201mm(L)*200mm(W)*170mm(H)

Weight: 1420g

Operation temperature: 0-40℃ (32-104℉)