

# Camera Waterproof Case

## User Manual

FOR SONY  $\alpha$ 7RIV

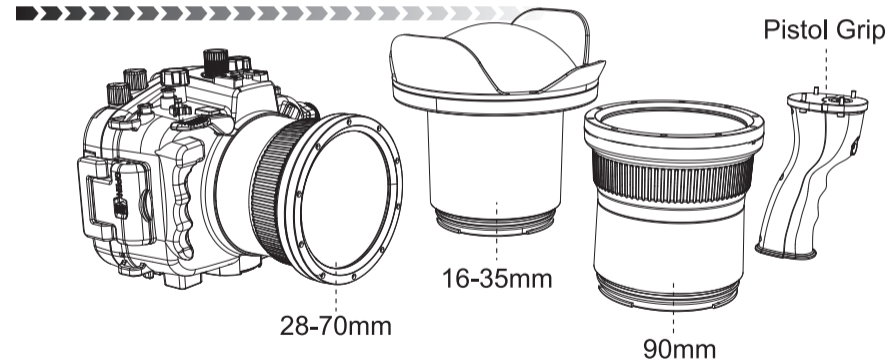

## Contents

---

Introduction .....	P02
Safety precautions.....	P03
Packing contents.....	P04
Component name.....	P05
Preparation works.....	P06
Sync cord installation.....	P07
Lens barrel replacement.....	P08
Pistol grip installation.....	P09
Use waterproof case.....	P10
O-ring and silicone grease.....	P11
Storage/Specification.....	P12

## ▶ Introduction

- Please read user manual carefully before use.
- Please keep user manual for future reference.
- Please use waterproof case when fully understand the contents of the user manual.
- Company does not assume any other liability arising from incorrect operation. Including but not limited to occasional or consequent of the damage or is the loss of profits or due to the use or failure to use the product cause work to stop or damage, etc.

## ▶▶ Safety precautions

- ※ When using waterproof case underwater, please pay attention to your current situation to avoid accident or injury.
- ※ When locating the waterproof case in a big temperature difference areas in a short time will cause condensation on the inner surface of the case (small water droplets)  
If condensation occurs, remove the camera from the waterproof case and wipe off it with soft cloth and the beads. Please use after the water vapor is completely evaporated.
- ※ Do not damage the waterproof o-ring, scratch its surfaces or allow hair, sand, dirt and other debris to accumulate between the waterproof o-ring and the case. This may cause an accident.
- ※ Do not use the waterproof case at temperature below 0°C ,higher than 40°C or underwater depth exceeding 100 meters.
- ※ Do not put waterproof case in hot, wet place or direct sunshine for a long time.
- ※ If leakage, stop using waterproof case immediately. Separate water and take out the camera in case of damage.

## ▶▶ Package contents

Waterproof case (1)	Cleaning cloth (1)	O-ring remove tool(1)
O-ring (1)	User Manual (1)	Disassembly tools(1)
Hand strip (1)	Silicone grease (1)	Anti-fog sheet(1)
Neck strip (1)	Pistol grip assembly(1)	M2.5 hexagonal spoon(1)

### ⚠ Optional assembly :

- \*(1)16-35mm lens barrelx1+(16-35mm)runner wheelx1
- \*(2)28-70mm lens barrelx1+(28-70mm)runner wheelx1
- \*(3)90mm lens barrelx1+(90mm)runner wheelx1

Please confirm that all the package accessories are complete when purchase.  
If there is any omission, please contact the dealer or manufacturer timely.

## ▶▶ Component name

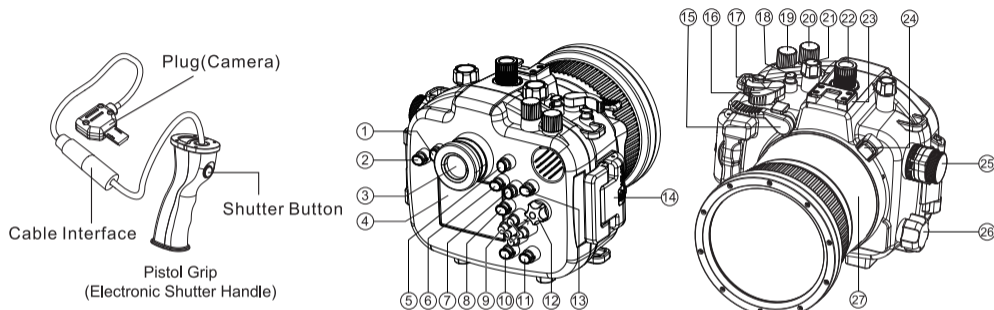

- 1、 Menu Button
- 2、 C3 Button
- 3、 Electronic Viewfinder
- 4、 Display Window
- 5、 AF-ON
- 6、 MOVIE Button
- 7、 Multi-Function Button

- 8、 Fn Button
- 9、 SET Button 
- 10、 Play Button/ 
- 11、 C4 Button/ 
- 12、 Control Dial
- 13、 AEL Button
- 14、 Safety Lock

- 15、 Shutter Button
- 16、 Power ON/OFF
- 17、 C1 Button
- 18、 C2 Button
- 19、 Exposure Compensation
- 20、 Back Dial
- 21、 Mode Dial

- 22、 Sync cord Socket
- 23、 Cold Shoe
- 24、 Lens Barrel Release Button
- 25、 Vacuum System Interface
- 26、 Focusing Control Knob
- 27、 Lens Barrel

## ▶▶ Preparation works

Adjust camera specification and ensure record video or picture has natural color. Before use the camera under sea, please ensure that your important picture and file has been transferred to the computer.

1. Install a fully charged battery, insert the memory card and make sure the memory card has enough room to record the image.
2. Remove the wristband from your camera.
3. Install camera compatible lens.
4. Turn on the camera and set the required parameters in advance.
5. Turn off the camera, select the corresponding wheel according to the camera lens focal section, then put the camera into the waterproof housing.
6. Close the waterproof case and secure the safety lock.  
(Note: do not clamp anything, such as a wristband, strap or hair on a waterproof case. It will cause leakage.) Repeat
7. press the case's buttons and dials to make sure the camera can work well.

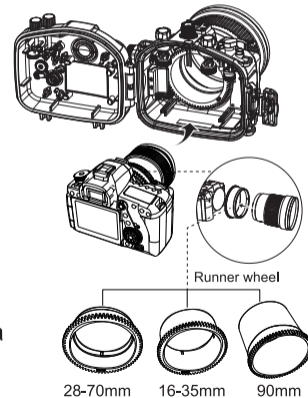

## ► Sync cord installation

- (1) Dismantle the camera lens and install the runner wheel to the lens;
- (2) Connect the sync cord plug inside the waterproof case to the camera hot shoe base, install the camera into the waterproof case and close the lock;
- (3) Connect the sync cord to the waterproof case sync cord interface and connect the strobe.

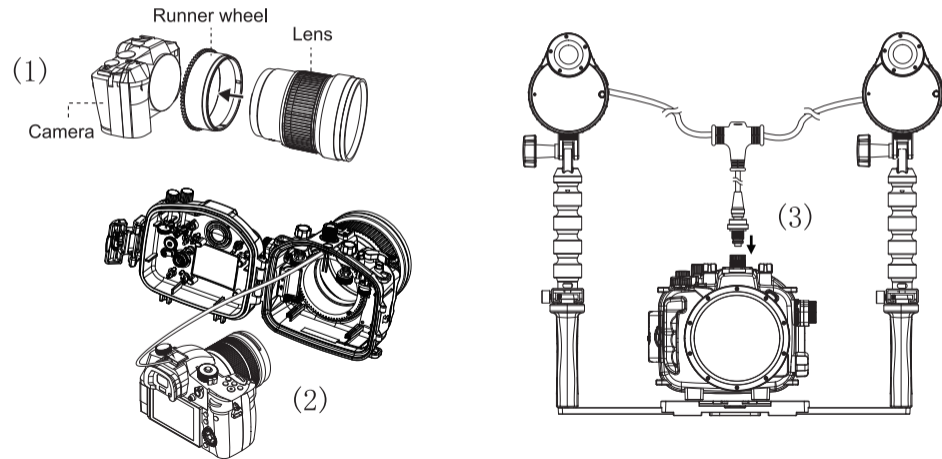

## ► Lens barrel replacement

This product is designed with three lens barrel, which support 16-35mm/28-70mm/90mm focal lenses respectively. If you bought two lens barrel, you can change them freely as required. The operation steps are as follows:

- (1) Press and hold the release button of lens barrel, and turn the lens barrel anticlockwise;
- (2) Pull out the lens barrel;
- (3) Select the lens barrel to be replaced, aim at it with the waterproof case bayonet, and then turn the lens barrel clockwise until it is locked.

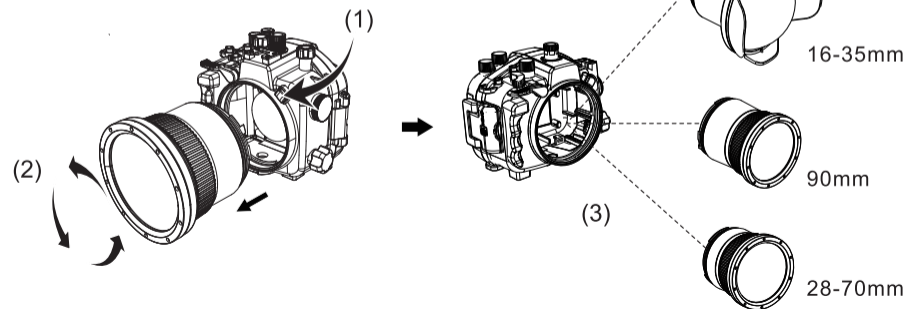

## ►► Pistol grip installation

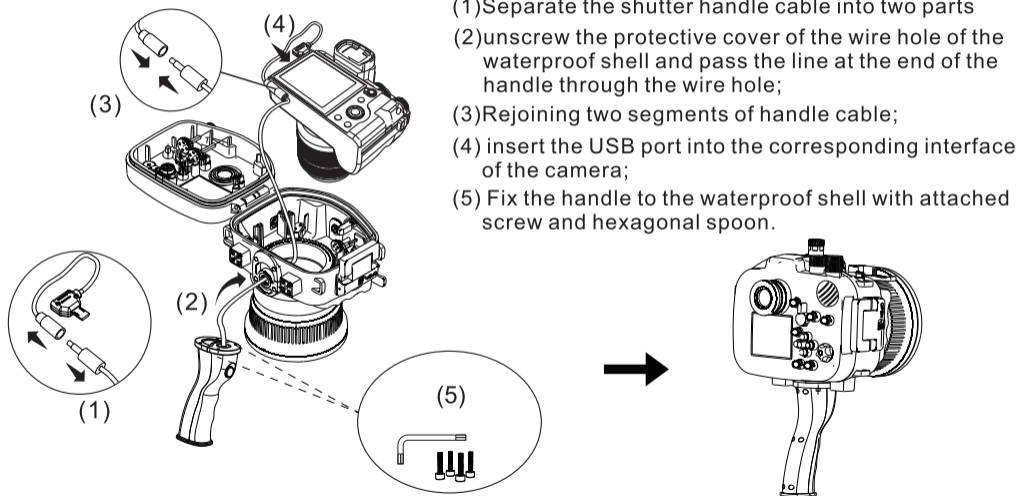

## ►► Use waterproof case

Before put camera into the waterproof case and use in the sea, please put the case into water about 1 meter first and ensure that the case can work well and no leakage. About more information about camera function, please check the user manual.

1. Press ON/OFF button to turn on the power.
2. Hold the camera in both hands and press the shutter button to shoot the image. The movie will not be able to record audio.
3. Remove camera. Press ON/OFF button to turn off the power. Open the safety lock and remove the camera from case. Before open the case, please use fresh water to clean and wipe it with soft dry cloth. When you open, don't spill the body, hair and diving suit's water on the camera.

## ► O-ring and silicone grease

The waterproof case use o-ring to maintain waterproof function. It's important to maintain o-ring. Improper use of maintenance and installation will case leakage.

- 1、Remove o-ring with finger. Do not use fingernails or sharp metallic objects.
- 2、Make sure there is no dirt,sand,hair,dust,salt and thread etc. If have, please use soft cloth to clean it. Use fingertips to gently wipe around the o-ring to see if there are invisible dirt. After wiping, be careful do not leave any fabric fibers on the o-ring. Check whether have cracks, twist, deformation, fine cracking, scratches, sand and others on the o-ring. If have, replace the new o-ring.
- 3、Check the o-ring mounting groove and make sure there is no debris in it.
- 4、Apply grease on o-ring. Drop a drop grease on your index finger, hold the o-ring between your index finger and thumb and slide your finger around the o-ring to applied it evenly. Grease has function of protection and prevent damage.
- 5、Put o-ring on fix mounting groove and make sure o-ring has no dirt, no twist and no raised. Do not pull the o-ring by hand.
- 6、Before install the camera, please close the waterproof case and put it into the water to check there is no leakage.
- 7、The o-ring's service life varies depending on the frequency and storage conditions of the waterproof case. Generally speaking, it is about one year. If o-ring is cracked or damaged, should replace a new o-ring. After replacement, please check leakage.

## ► Storage

- Keep the waterproof case open when storing it. This will prevent the waterproof o-ring seal from deforming, thus can ensure the waterproof function.
- Do not store the waterproof case in hot, cold, humid place or near naphthalene chemical and pesticide.
- Do not store the waterproof o-ring seal in a place where can accumulate dust and easy scratched.
- If you don't have plan to use the waterproof case for over a month, please remove the waterproof o-ring seal . Use your index finger and thumb, slide around the o-ring to wipe off the grease. Then place the o-ring in a clean plastic bag.

## ► Specification

Waterproof depth:40m/130ft

Compatible for:16-35mm/28-70mm/90mm

Waterproof element:O-Ring seal

Main material:Aluminum alloy,Optical glass,Stainless steel,EPDM rubber

Dimensions:219\*193\*176mm(28-70mm);242\*193\*176mm(90mm);

312\*212\*223mm(16-35mm);42.7\*81.3\*132.6mm(pistol grip)

Weight:1543g(28-70mm);1618g(90mm);1764g(16-35mm);75g(pistol grip)

Operation temperature:0-40°C(32-104°F)