

Mockmill



DE
EN
FR
ES

OPERATING INSTRUCTIONS

Mockmill LINO 100

Mockmill LINO 200

Mockmill Professional 200

Stone mill for milling grains,
pulses and spices

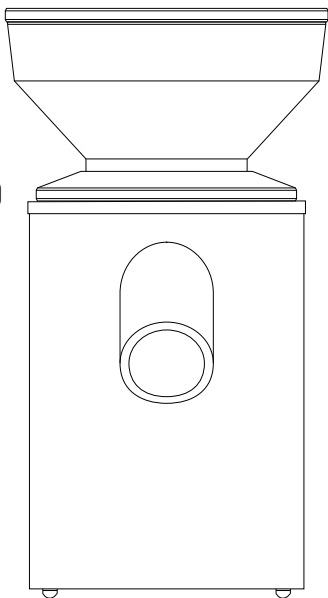

Please read the operating instructions before using your Mockmill for the first time to protect yourself from injury and avoid damaging the appliance.

PUT FRESH FLOUR IN YOUR LIFE
get the most out of grains

taste

FRESHLY
GROUND
FLOUR

TASTES BETTER

feel

HOME-MADE
FOOD IS GOOD
FOR YOU

AND WHOLESOME

explore

ANYONE
CAN BAKE GOOD
BREAD

JUST TRY IT



**JOIN THE
FOOD
REVOLUTION**

Dear customer,

We are very pleased that you have purchased one of our mockmills and we welcome you to the world of whole grains:

Taste: Freshly ground flour tastes better

Feel: Homemade is good for you and easy to digest

Explore: Everyone can bake good bread - just give it a try!

Put your Mockmill to work right away and enjoy the variety, the great taste and aroma of the freshly ground whole grains.

We hope you will enjoy discovering and enjoying your own new creations.

We hope you'll have feedback for us!

Best regards

Paul Lebeau and Martina Mock.

Welcome to the world of Mockmill!

QUICK GUIDE

ATTENTION:

Before starting your Mockmill LINO 100/200 for the first time, you'll need to remove the transport lock. To find out how, check page 11.

Getting started – Please follow in order

1. Connect the plug to the power socket
2. Place a bowl beneath the chute
- 3. Switch on the mill**
4. Select milling grade
5. Empty a handful of grains into the hopper
6. Let the mill complete the milling
7. Switch the unit off
8. Discard the resulting flour, as this first milling removes any mineral particles left over from the manufacturing process.

Contents

Welcome	page 3
Quick Guide	page 4
Precautions and safety notices	page 6
Components	page 8
Getting started and cleaning	page 9
Opening the Mockmill	page 10
Further operating instructions	page 11
What foods can I mill with the Mockmill?	page 12 - 14
Choosing milling settings	page 15
Troubleshooting	page 16
Warranty and repair	page 17
Transport packaging and recycling	page 18
Technical details and contents	page 19
Contact info	Back cover

PRECAUTIONS AND SAFETY NOTICES

Please read carefully before using your Mockmill for the first time.

Selecting grain

Use only cleaned grains. Unclean grain may contain small stones that can damage the milling stones.

Milling foods or substances other than those listed on pages 12–14 can damage your mill and void the warranty. In case of doubt, please contact us by sending an e-mail to **info@mockmill.com**

Only use dry grain for milling

Moist grain will lead to the build-up of a film on the milling stones. You can remove the film simply by milling dry grain on a coarse setting. (Operating instructions p. 7).

If in doubt, press a kernel onto a hard surface with the back of a spoon: If it breaks with a loud crack, the grain is dry.

Grains that are too damp for milling can be squashed flat and then they look like a rolled oat. Rye should be stored for at least six months following harvesting before milling.

More information about the different grain types and their uses as well as the adjustment of the milling grades can be found on our website under **mockmill.com** → Service/Help → Help/Support → Downloads.

Milling spices

The Mockmill easily handles dried spices and seasonings, including pepper, coriander, cardamon, cinnamon, and more. Please note that some spices, such as cinnamon, may need to be broken into pieces small enough to feed into the Mockmill.

To flush the mill of the aroma of milled spices, simply mill a small amount of grain (such as wheat) right away. Then use this “flavored flour” to add aroma to your baking or sauces!

Oily/fatty foods

Please refrain from milling nuts or oily foods such as sesame, flax, or poppy seeds. Even coffee beans contain a great deal of oil, which leaves a film on the milling stones, rendering them incapable of processing the grain properly. However, you have the option to mill oily products or fresh herbs by milling them together with dry grains (mixing ratio: 5% oily product to 95% dry). Immediately afterwards, clean the Mockmill as described on page 9.

How to clean the milling stones and milling chamber

Choose a coarse setting and mill about half a cup of dry grain, such as wheat. Move the lever from coarse to fine and back

again while milling. Milling on a very coarse setting, so that the grains are just broken, will quickly remove any film from the milling stones. For thoroughness the grains can be passed repeatedly through the Mockmill. Use this cleaning process right away any time you have included oilseeds in your milling.

In severe cases, when a hard film has built up on the stones, it is advisable that a few slits be cut into the film's surface with a sharp object, such as the tip of a paring knife. This creates a starting point for the cleaning process.

Supervision

The Mockmill is a piece of electrical equipment and should only be used under proper supervision (and not by children).

Warning

Keep hands and other objects (such as spoons or screwdrivers) away from the milling mechanism at all times while the unit is switched on.

Failure to do so could cause injury (to the fingers) and/or damage the milling stones.

Cleaning

Never submerge the Mockmill in water or any other liquid. Wipe the casing clean with a slightly

damp cloth. It is important that no water enter the mill. The millstones should never be cleaned with water or a wet cloth! (Please see the section “Cleaning the Mockmill”). Always disconnect the appliance before cleaning.

COMPONENTS

A: Hopper cover

B: Hopper

C: Scale

D: Chute

E: Power switch

F: Power cable

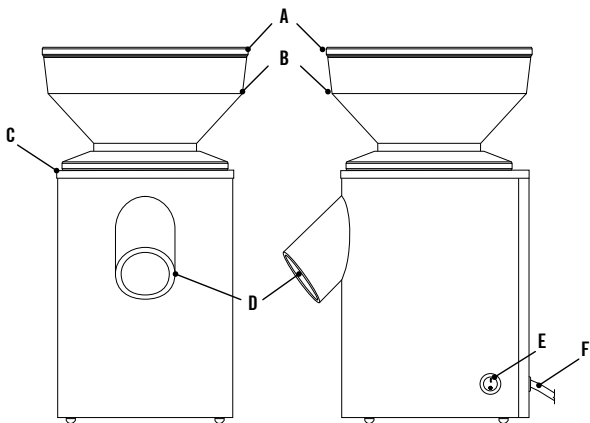

GETTING STARTED AND CLEANING

ATTENTION:

Before starting your Mockmill LINO 100/200 for the first time, you'll need to remove the transport lock. To find out how, check page 11.

Before first use

Please mill a handful of grain on scale 6 and then discard the flour. This will remove any mineral debris from the manufacturing process on the milling stones.

Getting started – Please follow in order

1. Connect the plug to the power socket
2. Place a bowl beneath the chute
3. **Switch on the mill**
4. Select milling grade
5. Empty a handful of grains into the hopper
6. Let the mill complete the milling

7. Switch the unit off
8. Discard the resulting flour, as this first milling removes any mineral particles left over from the manufacturing process.

Don't switch the Mockmill off while it is milling.

ALWAYS switch the Mockmill on prior to loading the hopper!

IMPORTANT: If you hear the sound of stone contact before reaching position 1 while adjusting downwards, please check the section “Choosing milling settings” on Page 15.

Cleaning

The milling stones clean themselves if you select a coarse setting from time to time. If the mill is not to be used for a while (extended vacation, for example), we recommend removing flour residues by milling on a coarser setting. Please see “How to clean the Mockmill” on p. 7.

OPENING THE MOCKMILL

If the Mockmill is not operating properly, or if heavy soiling is suspected it makes sense to open the Mockmill. Then you can remove grain residue from the milling chamber and clean the two stones using a soft brush or a wooden spatula. Be careful not to lose the two small springs that support the upper stones! Please follow the instructions below.



Please disconnect the Mockmill from the power socket before opening. Turn the hopper anti clockwise.

You can now lift the upper stone (stator) and control the milling surfaces.



If a hard film has built up on the stones please see page 17 where we show how such a film can be removed. Now the stator can be put back into place so that the black mark on the stator is above the chute. Then you can remove grain residue from the milling chamber and clean the two stones using a soft brush or a wooden spatula. Be careful not to lose the two small springs that support the upper stones!



Take the hopper and turn it one full time clockwise. Then plug the mill into the power socket and switch on. Turn the mill further until you hear a slight ticking noise (first stone contact).

FURTHER
QUESTIONS?
info@mockmill.com

REMOVE THE TRANSPORT LOCKING DEVICE (ONLY FOR MOCKMILL LINO 100/200)

Please make sure the transport locking device is removed before the initial start up. Holding the chute with one hand, turn the hopper anti clockwise with the other hand. **Remove the hopper.** It is normal that some strength is required.

The transport locking device can now be removed by pulling on the red tag.

The hopper can now be placed back onto the mill by turning this clockwise until you feel a strong resistance. At this point turn the hopper anti clockwise until the black dot is above the scale number 1. Now you can use your Mockmill as described in operating instructions.

FURTHER OPERATING INSTRUCTIONS.

On our homepage **mockmill.com** you will find videos containing further operating instructions under:

mockmill.com → Service/Help → Help/Support → Downloads

SUBSTANCES FOR MILLING AND ADJUSTING THE SETTINGS

You can use your Mockmill to mill the following substances:

<u>Soft Grains</u> <u>Hard Grains</u> <u>Seeds</u> <u>Legumes</u>	Milling Scale LINO 100	Milling Scale LINO / Professional 200	Essential oils	Special Notes
Amaranth	0–1	0–1	–	
Buckwheat	0–1	0–1	–	Only hulled and not pre-toasted
Chia seeds	6–7	7	–	
Spelt	1	1–2	–	
Einkorn wheat	1	1–2	–	
Emmer wheat	0–1	1	–	
Green spelt	1	1	–	
Oats	3	4–5	–	
Dried peas	1	1	–	
Millet	1	1	–	
Kamut	1	0–1	–	
Chickpeas	1	1	–	
Kidney beans	1	1	–	
Lentils	1	1	–	

<u>Soft Grains</u> <u>Hard Grains</u> <u>Seeds</u> <u>Legumes</u>	Milling Scale LINO 100	Milling Scale LINO / Professional 200	Essential oils	Special Notes
Lupin seeds	2	2	–	
Corn/Maize	1–2	1–2	–	No Popcorn
Milo (Grain Sorghum)	0–1	2–2,5	–	
Hulled barley	1	1	–	
Natural long grain rice	0–1	0–1	–	No parboiled rice
Pinto beans	2	1–2	–	
Quinoa	0–1	0–1	–	
Rye	1	1	–	
Soya beans	1–2	5	–	
Teff	0–1	0–1	–	
White beans	0–1	0–1	–	
Wheat	1	1	–	

<u>Herbs & Spices</u>	Milling Scale LINO 100	Milling Scale LINO / Professional 200	Essential oils	Special Notes
Anis whole	4	4–5	√	
Fenugreek seeds	1	2–2,5	–	
Fennel seeds	2	3	√	
Rosemary (dried)	2	2	–	
Cardamon pods	0–1	0–1	√	
Coriander seeds	1	2	√	
Cumin	4	4	√	
Caraway seeds	4–5	5	√	
Cloves	3	4	√	
Allspice	1	1	–	
Star Anise	2–3	3	√	Cut into small pieces
Pepper	2	2	–	
Tonka beans	9–10	10	√	
Cinnamon flowers	0–1	2	√	
Cinnamon sticks	1	1	–	Cut into small pieces

SUBSTANCES FOR MILLING AND ADJUSTING THE SETTINGS

You can use your Mockmill to mill all foods listed on pages 12–14.

Milling substances other than those listed or on our website may damage your mill and void the warranty.

Do you have an idea or would you like to try something that you can not find on the list? Then please send us a mail to **info@mockmill.com**. We would like to support you and your milling ideas.

The Mockmill is set so that you can hear a slight ticking noise from stones at scale position 1 when idling without grain. That is the finest setting. If no stone contact is heard at position 1, keep turning the hopper past that position until you hear a light ticking noise.

At position 20 you will get coarse meal coming from the Mockmill. When an even coarser result is required then you can keep turning the hopper well past the end of the scale. There is no limit here, but at some point past 20 your grains will exit the mill whole.

A video on this topic can be found on our website under: **mockmill.com** → Service/Help → Help/Support → Downloads

TROUBLESHOOTING

In the unlikely event that you experience a problem with your Mockmill, or should you have any questions as to how it works, please call us or send us an e-mail to **info@mockmill.com** (USA to **support@mockmill.com**). Our experts can solve virtually all problems on the phone.

Listed below are some possible problems and how they can be usually resolved.

The mockmill is humming, but it does not mill

Switch off the Mockmill and adjust the scale to position 10. Turn the Mockmill on. The milling should start again.

Please make sure that you always switch the Mockmill first and then fill with grains.

When the Mockmill is still humming

Switch off the Mockmill and remove the plug from the socket. To remove the grains from the hopper, carefully lift and invert the Mockmill, pouring the grains into a bowl. Then turn the hopper past position 20. The mill can now be switched back on. The food causing the jam will be discharged. Now plug the Mockmill back in, switch it on, and adjust the scale to the required fineness. Now load the hopper with the grains and discharged food to continue milling.

Please make sure that you always switch the Mockmill on first and then fill the hopper with grains.

Buildup on the milling stones

In the case that a hard film has formed on the stones, one that doesn't disappear simply by milling hard grains on a coarse setting, please open the Mockmill as described on page 10. Using a sharp tool, such as a paring knife, make a few gashes across the film's surface. Put the Mockmill back together, as shown starting on page 11, step 4, and mill on a very coarse setting 1 - 2 cups of hard grains. The gashes you made provide a point of attach for the coarse grains, and they will now be able to remove the film.

WARRANTY & REPAIR

The Mockmill is guaranteed by Wolfgang Mock GmbH for home use against material and manufacturing defects for a period of 12 years and for commercial use 2 years from the date of purchase. Please register your device online under **mockmill.com** → Service/Help → Help/Support → Downloads to validate your warranty.

The warranty does not cover damage to fragile parts, such as the hopper or flour chute, when caused by improper use. These can, however, easily be replaced at a little or no cost to you. We will repair or replace any defective Mockmill within the warranty period.

If repair or replacement parts are required, please call us or send an email to **info@mockmill.com** (USA to **support@mockmill.com**) before returning the defective mill so that we can locate the nearest authorized service center for you.

TRANSPORT PACKAGING AND RECYCLING

Transport packaging

The packaging protects the Mockmill from transport damage. Keep the original box and the internal packaging, so that you can transport the appliance safely at a later date.

Disposal of an old appliance

Only for the European Union and countries with recycling systems. The crossed out wheellie bin logo that is featured on products, packaging and/or accompanying documents means that you must neither place used electrical and electronic items nor batteries into the general waste container.

You must instead comply with the statutory regulations and take old products and used batteries to your local facility for treatment, reprocessing and/or recycling. By disposing of these products and batteries in the appropriate way, you help protect valuable resources and prevent potentially negative effects on human health and the environment. For more information on collecting and recycling waste,



please contact your local waste disposal service provider. In accordance with national regulations, failing to dispose of such waste in the correct way may lead to fines.

Never throw the Mockmill in your household trash.

Instead, make use of the official collection centers for the recycling of electrical and electronic devices operated by your local authority, your dealer or Wolfgang Mock GmbH. It is your legal responsibility to eradicate at the time of disposal any personal information you inscribe on the appliance. Please ensure that when decommissioned, your appliance is stored out of the reach of children.

TECHNICAL DETAILS AND CONTENTS

	LINO 100	LINO 200	Professional 200
Content			Can mill for hours
Voltage	230 V / 110 V	230 V / 110 V	230 V / 110 V
Power 50 Hz / 60 Hz	360 W	600 W	600 W
Milling Speed 50 Hz	approx. 1300 rpm	approx. 1300 rpm	approx. 1300 rpm
Milling Speed 60 Hz	approx. 1500 rpm	approx. 1500 rpm	approx. 1500 rpm
Protection Class	1	1	1
Dimensions	380 x 242 x 208 mm 15 x 9.5 x 8 inch	380 x 242 x 208 mm 15 x 9.5 x 8 inch	380 x 242 x 208 mm 15 x 9.5 x 8 inch
Milling mechanism	Countund ceramic milling stones	Countund ceramic milling stones	Countund ceramic milling stones
Milling stone diameter	90 mm	90 mm	90 mm
Milling grades	Variable from very fine to coarse	Variable from very fine to coarse	Variable from very fine to coarse
Milling efficiency with wheat	approx. 100 g/Min approx. 3.5 oz	approx. 200 g/Min approx. 7 oz	approx. 200 g/Min approx. 7 oz
Casing	Wood, Arboblend®	Wood, Arboblend®	Wood, Arboblend®
Hopper capacity with wheat	1.300 g / 2 lbs 14 oz	1.300 g / 2 lbs 14 oz	1.300 g / 2 lbs 14 oz
Weight	7,8 kg / 17 lbs 3 oz	8,9 kg / 19 lbs 9 oz	9,4 kg / 20 lbs 11.5 oz
Cable length	135 cm 4,43 ft	135 cm 4,43 ft	135 cm 4,43 ft

Technical changes reserved.

Contents

Mockmill with hopper cover, User manual

Mockmill LINO 100
Mockmill LINO 200
Mockmill Professional 200

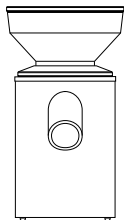

MODE D'EMPLOI

Moulin à pierre pour la mouture des grains, légumineuses et épices.

Vous trouverez la version actuelle du manuel d'utilisation sur notre site mockmill.com à l'onglet:

INSTRUCCIONES DE USO

Molino de piedra para moler granos, legumbres y especias.

Para obtener el manual en español en su versión actual consulte nuestra página web mockmill.com en:

mockmill.com → [service/help](http://mockmill.com/service/help) → [help/support](http://mockmill.com/help/support) → Downloads

Veuillez lire le mode d'emploi avant d'utiliser votre moulin pour la première fois pour vous protéger des blessures et éviter d'endommager l'appareil.

Por favor, lea las instrucciones de uso antes de usar su Mockmill por primera vez para protegerse de lesiones y evitar dañar el aparato.



WOLFGANG MOCK GMBH

Marie-Curie-Str. 5
64823 Groß-Umstadt
Germany
+49 6162 50 99 660
info@mockmill.com

mockmill.com

