



LookingForSolutions.com



**Ambient Temperature, Relative Humidity, Dew Point
Temperature, Ambient Light, Barometric Pressure,
Reference Altitude Sensors to USB-WiFi-Alarm Output
Model LFS104A-LFS104AW**

Table of Contents

Quick Start	3
1- Introduction	4
1.1 – Firmware Update	8
2- Settings Menu.....	9
2.1- Sensor Board Calibration (USB or WiFi Connection)	10
2.2- Read/Configure WiFi Module – Connect to WiFi Network (LFS104AW)	11
2.3 – Set WiFi Module to Serial Mode	13
2.4 – Read Data from Web browser (LFS104AW)	14
2.5 – Send Data to the Cloud – IoT (Thingspeak.com), Direct.....	15
2.6- Email Data/ Picture on alarm condition	17
2.7- Sending Text Message on alarm condition from PC.....	17
2.8- Send Data to the Cloud – IoT (Thingspeak.com) from PC.....	17
2.9- Verbalize on Alarm conditions	18
2.10- Take a Picture on Alarm conditions	19
2.11- Configure Board Alarm outputs (USB or WiFi Connection)	19
3- Saving Data to the Storage Cloud.....	20
4- Specifications.....	20
5- PC Commands	22
6- Troubleshooting.....	23
7- Third Party Software & Devices.....	25

Quick Start

To quickly setup and start your board, follow the steps below:

- Download the software (LFS104A.zip) from the website to your desktop.
- Unzip the file. Run setup.exe to install the software.
- Connect the board to your PC USB port via USB cable provided.
- The PC should recognize the board and install the USB drivers. Otherwise, go to Device Manager/Ports to install the USB driver which is located on your desktop.
- From PC software, read/change alarm output set points – See section 2.11
- From PC software, read/configure WiFi module, connect to WiFi network-See Section 2.2

Other Options

If you are not using a PC, you can do any of the following:

- Power the board using a USB charger and use the alarm output signals.
- Power the board using a USB charger, connect to WiFi network and send data to the cloud (LFS104AW) – See Section 2.5.
- Connect the board to a Raspberry Pi computer board. Communicate with the board using the sample Python code provided. You can collect data from the board, or send data to the cloud, email data on alarm, etc.

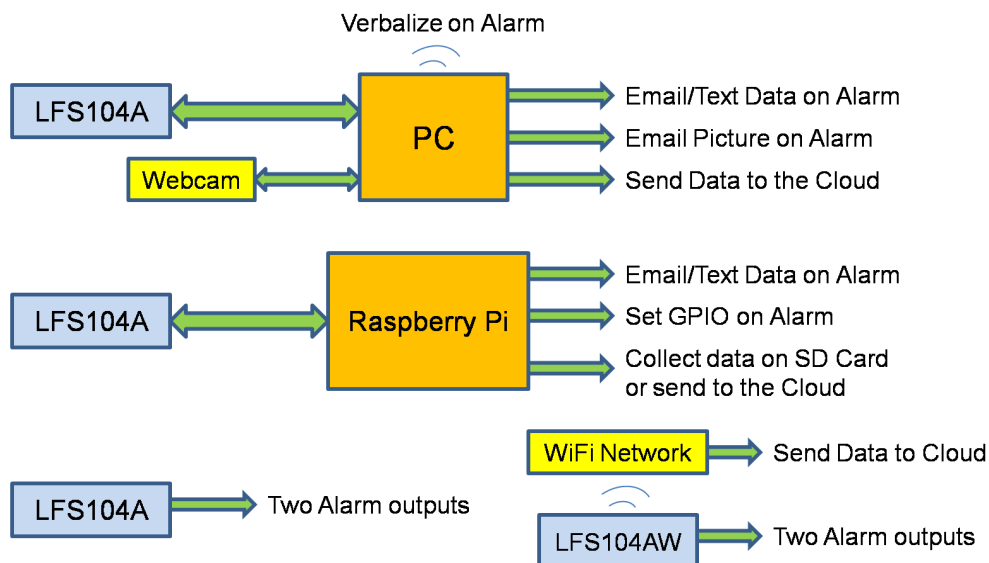

1- Introduction

LFS104A is an ambient temperature, relative humidity, dew point temperature, ambient light, barometric pressure, and reference altitude sensors to USB-WiFi-Alarm output. First, install the application software. Simply download the software from the web site LookingForSolutions.com. Save the zipped file (LFS104A.zip) onto your desktop. Unzip the file. Run setup.exe to install the software. The software will place a shortcut of the program on the desktop. Save the USB driver directory (from the zipped file) on the desktop.

Second, connect the board to your PC USB port with the cable provided. The PC will recognize the board and will start installing the USB drivers. You can view the COM port by going to the Device Manager/Ports. You can also install the USB drivers from the Device Manager/Port/Driver/Update Driver and point the PC to the USB driver directory on the desktop. Now you can run the software from the shortcut on the desktop.

Figure 2 shows the main screen. You can set the COM port and the Chart Speed (Time interval per data point) from the drop down menus. Click the Start button. The program asks for the name of data file to be saved. You can name your data file (Filename.txt or Filename.csv) and the location where you want to save it. Click the Save (or Cancel) button. The program will start reading and displaying the ambient temperature, relative humidity, dew point temperature, ambient light, barometric pressure, reference altitude from the board and provides a line graph of the six parameters. It also shows the model number of the board (LFS104A) and the running Elapsed time.

The program keeps track of the Maximum and Minimum values of temperature, relative humidity, dew point, ambient light, barometric pressure, and reference altitude since the start of the session which can be reset individually by pressing the corresponding Reset button. The temperature, dew point, ambient light, barometric pressure, and reference altitude can be displayed and saved in different Engineering units by pressing the corresponding engineering unit button. You can display High & Low alarm lines over the temperature, humidity, ambient light, and barometric pressure graph lines.

Live Video - There is a Live Video button on the upper right corner of the screen. Clicking the button will open a new window connecting you to the built-in webcam of your PC or an external

webcam connected to the PC USB port. If there are multiple webcams, you will see a drop down menu to select the one you want to connect to. Once connected, you will see a live video of the event through the selected webcam. This feature allows monitoring an event live and take a picture of the event when there is an alarm condition. The picture and the corresponding data can also be emailed to alert the user. Figure 1 shows how the webcam is setup.

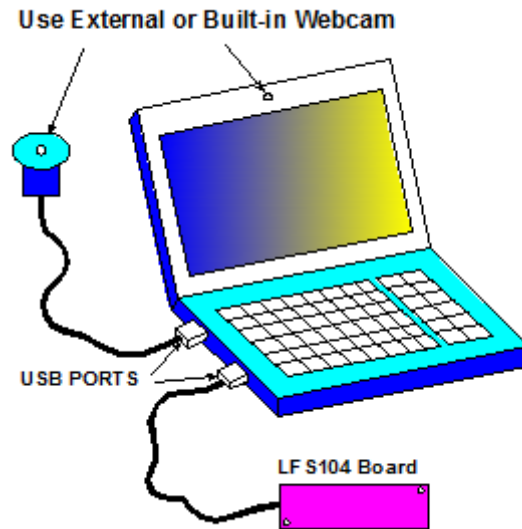

Figure 1 – Typical Webcam Setup



Figure 2 – Main Screen – Real Time, USB Connection

Review Past Data - Clicking the Hold or Stop button will stop the monitoring. You can now review the past data by scrolling through the line graphs back and forth in time as shown in Figure 3. Clicking the Hold button temporarily will stop the monitoring, you can continue by clicking the Go (Same) button. Clicking the Stop button will stop the monitoring permanently. You will need to start a new monitoring session by clicking the Start button.

When saving a data file (.txt or .csv), the program opens a file and saves up to 20,000 sets of data with date/time stamping, before closing the file and opening a new one.

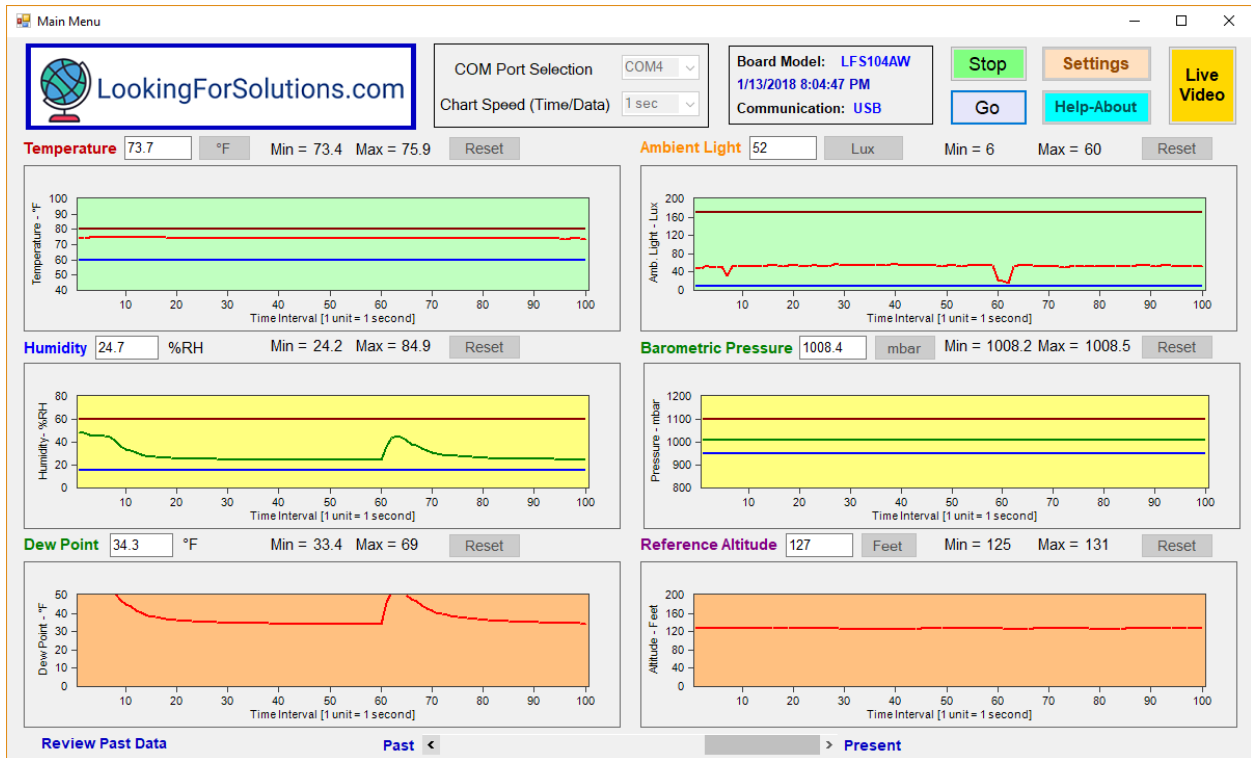

Figure 3 – Main Menu – Review Past Data

Help-About - Clicking the Help-About button will open a new window showing the board picture, firmware version, hardware version, serial number, and the PC software version, see Figure 4.

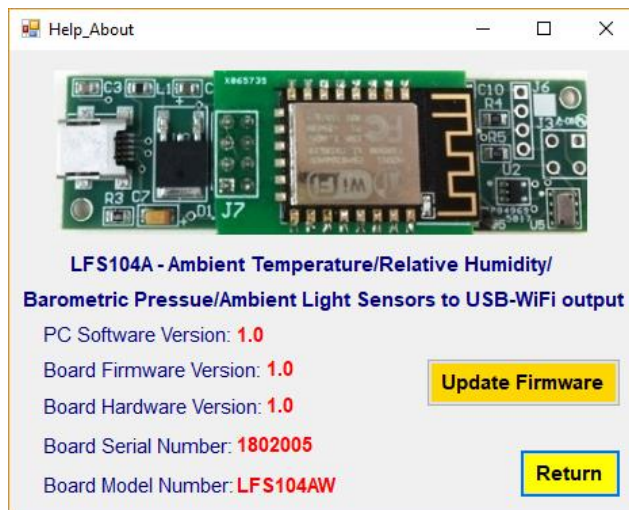

Figure 4 – Typical Help-About Screen

1.1 – Firmware Update

From the Help-About screen you can update the board’s firmware. Click on “Update Firmware” button. A windows popup will display instructions about the update.

- Download the latest firmware (HEX file) from the website (Lookingforsolutions.com)
- Place a Jumper across connector J5.
- Recycle Power to the board. Click OK to continue.
- A new window will open connecting the board to the USB bootloader software (Figure 5)
- Click “Open Hex File” button to load the Hex file.
- Click “Program/Verify” button to program the board.
- Close the program. Remove Jumper across J5 and Recycle power to the board.

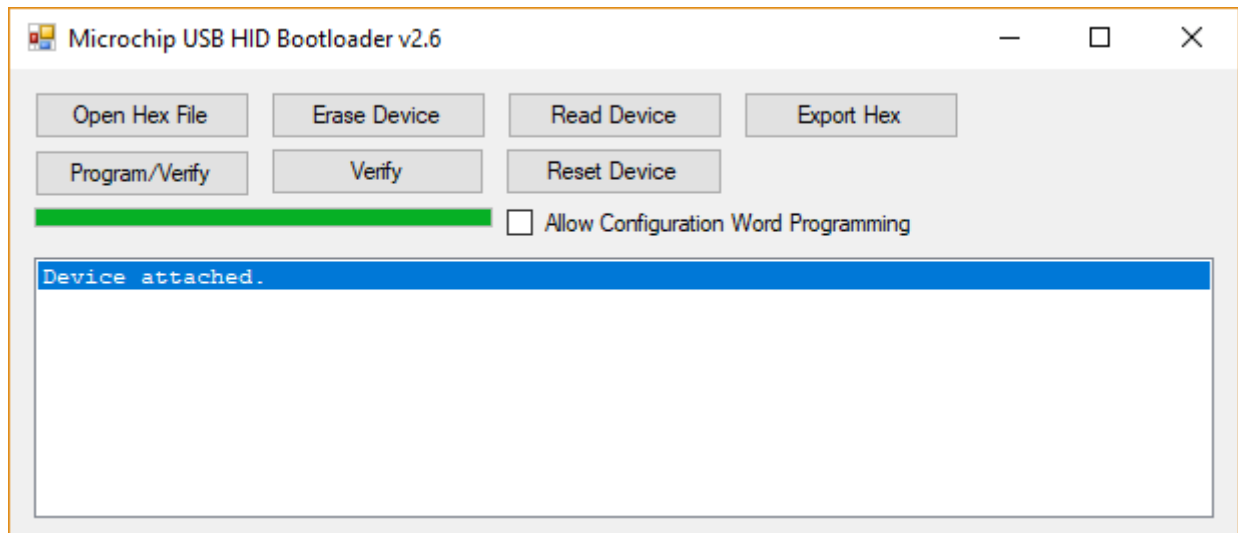

Figure 5 – Bootloader Software Screen

2- Settings Menu

Figure 6 shows the Settings Menu. Here is a list of functions you can perform:

- Read/Configure WiFi module. Connect to WiFi Network (LFS104AW)
- Re-scale the Temperature Y-Axis
- Re-scale the Relative Humidity Y-Axis
- Re-scale the Dew Point Y-Axis
- Re-scale the Ambient Light Y-Axis
- Re-scale the Barometric Pressure Y-Axis
- Re-scale the Reference Altitude Y-Axis
- Set High and Low Alarm set points for Temperature
- Set High and Low Alarm set points for Relative Humidity
- Set High and Low Alarm set points for Ambient Light
- Set High and Low Alarm set points for Barometric Pressure
- Configure Board Alarm outputs
- Calibrate the Board for Temperature, Humidity, Ambient Light, Barometric Pressure
- Restore the Board to Factory Calibration
- Record (Save) data to a file on alarm conditions
- Email Data/Picture on alarm conditions. Send a test email
- Send Text Message on alarm condition. Send a test Text Message
- Send data to the Cloud – IoT (Thingspeak.com) from the PC
- Take a Picture on alarm condition
- Verbalize on alarm condition

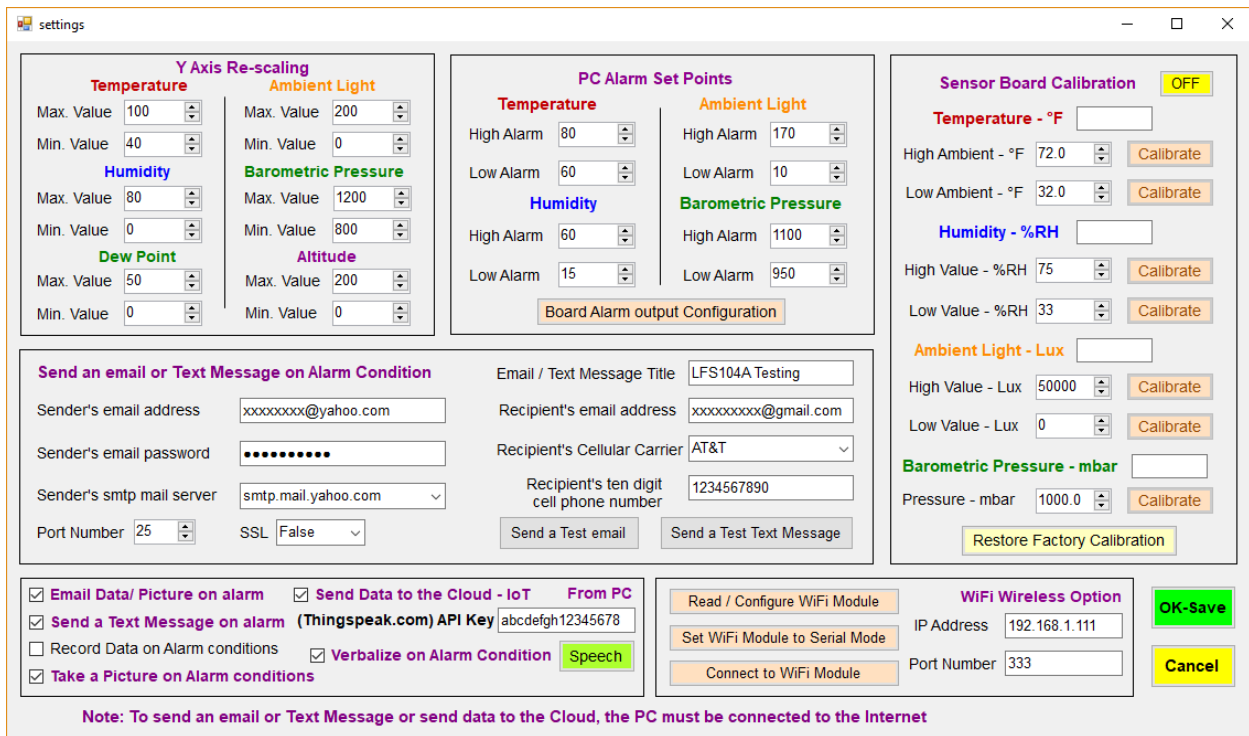

Figure 6 – Settings Menu

2.1- Sensor Board Calibration (USB or WiFi Connection)

You need to Turn ON the calibration function by clicking the OFF button. The current Temperature, Humidity, Ambient Light, and Barometric Pressure values will be displayed in the text boxes.

Temperature – You can calibrate the board for ambient temperature at two points in °F. Place the board in a known ambient temperature. Set the temperature calibration accordingly. Click the Calibrate button. You will see a windows popup “Low Temp Cal OK” or “High Temp Cal OK” to confirm low or high calibration.

Humidity – You can calibrate the board for relative humidity at two points in %RH. Place the board in a known humidity chamber. Set the humidity chamber to a low humidity like 33%. Set the Low value humidity to 33%. Click Calibrate button. You will see a windows popup “Low Humidity Cal OK” to confirm low humidity calibration.

Set the humidity chamber to a high humidity like 75%. Set the High humidity value to 75%. Click Calibrate button. You will see a windows popup “High Humidity Cal OK” to confirm high humidity calibration.

Ambient Light – You can calibrate the board for ambient light at two points in Lux. Place the board in a known ambient light. Set the ambient light calibration accordingly. Click the Calibrate button. You will see a windows popup “Low Light Cal OK” or “High Light Cal OK” to confirm low or high calibration.

Barometric Pressure – You can calibrate the board for barometric pressure at one point in mbar. Place the board in a known barometric pressure environment. Set the barometric pressure calibration set point accordingly. Click the Calibrate button. You will see a windows popup “Pressure Cal OK” to confirm calibration.

In case you made a mistake or want to go back to the original factory calibration, simply click “Restore Factory Calibration”. You will see a windows popup “Reset Factory Cal OK” to confirm.

2.2- Read/Configure WiFi Module – Connect to WiFi Network (LFS104AW)

The board has a wireless WiFi option where you can read/configure the WiFi module and connect to the WiFi network. From the settings menu, click “Read/Configure WiFi Module” button. A new window will open as shown in Figure 7. You can do any of the following:

- Scan Local WiFi networks
- Connect to a WiFi network by selecting the network and entering the password
- Set the WiFi module as a TCP client sending data to the Cloud (Thingspeak.com) by entering the API key and selecting the data sample rate.

Once the board is connected to a WiFi network, the window will show the board’s IP address, port number, and the connected network SSID.

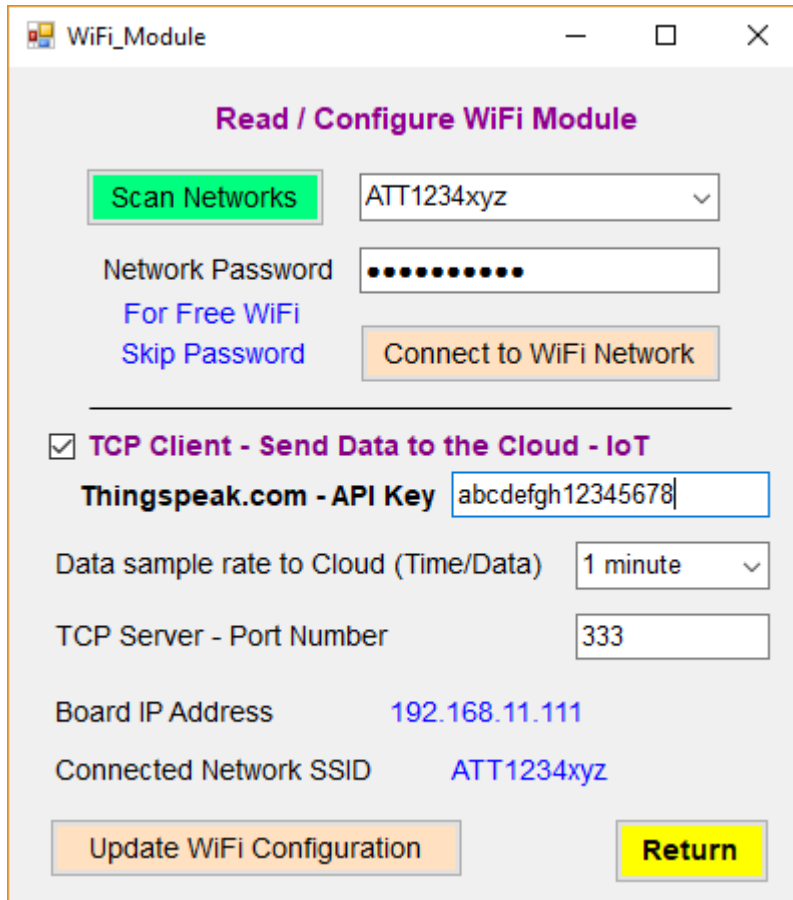

Figure 7 – Read/Configure WiFi Module Menu

Close the Read/Configure WiFi window. Click on “Connect to WiFi Module” button in the settings menu. The PC software is now connecting to the WiFi module and can communicate with the board via WiFi communication. You can calibrate the board via WiFi. You can read/configure alarm outputs via WiFi. You can read and log all the sensor data in real time via WiFi as shown in Figure 8.

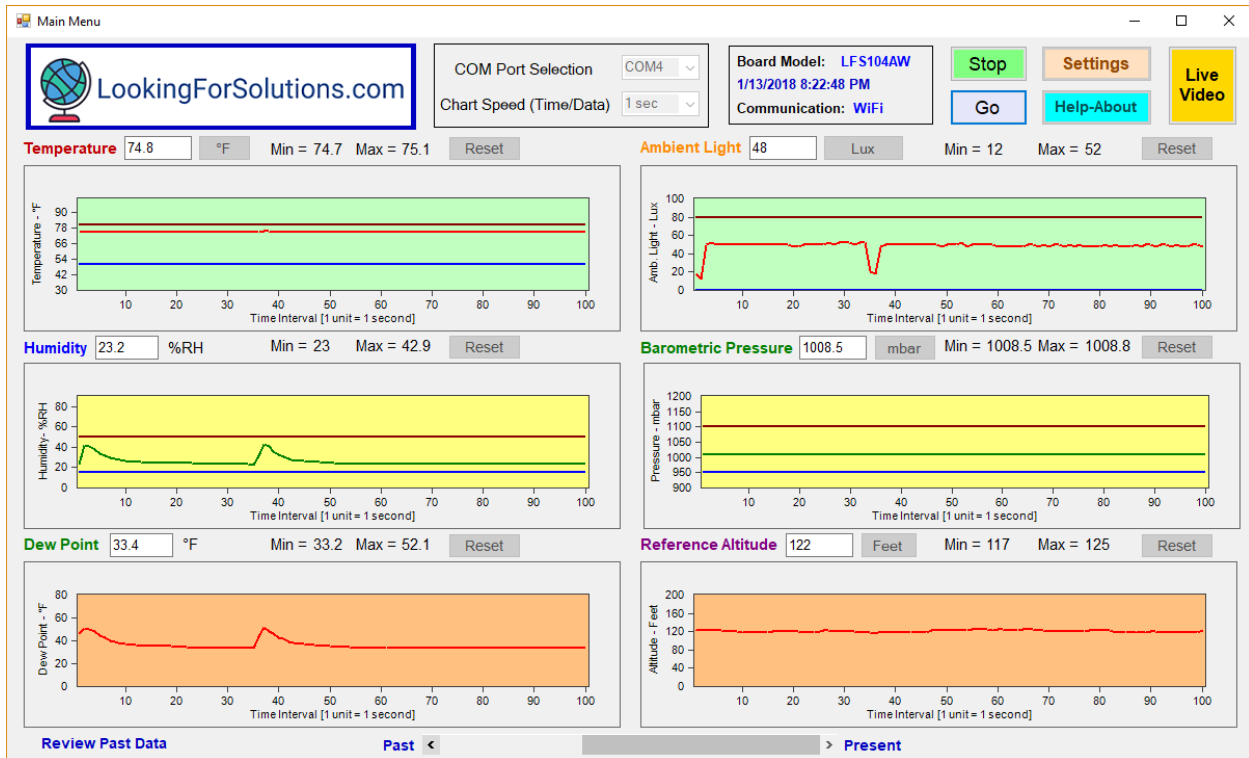

Figure 8 – Main Menu - Review Past data, WiFi Connection

2.3 – Set WiFi Module to Serial Mode

From the settings menu, you can set the WiFi Module to Serial mode by clicking “Set WiFi Module to Serial Mode” button. After the confirmation, close the PC program. Recycle power to the board. You can now communicate directly to the WiFi module from the USB port.

Use a terminal emulator (e.g. Teraterm) program to communicate with the WiFi module of the board. Set the communication settings to 115,200 baud rate, 1 stop bit and no parity. You can use any of the AT commands (Document is included) to communicate and make setting changes to the WiFi module. When done, close the terminal emulator program. Recycle power to the board and use the board normally.

2.4 – Read Data from Web browser (LFS104AW)

You can read all the sensor data from the board from a Chrome or an Internet Explorer web browser from any device. Simply type in the IP address and the port number of your board on the web browser URL (address) bar. The browser will display 20 sets of current sensor data as shown in Figure 9.

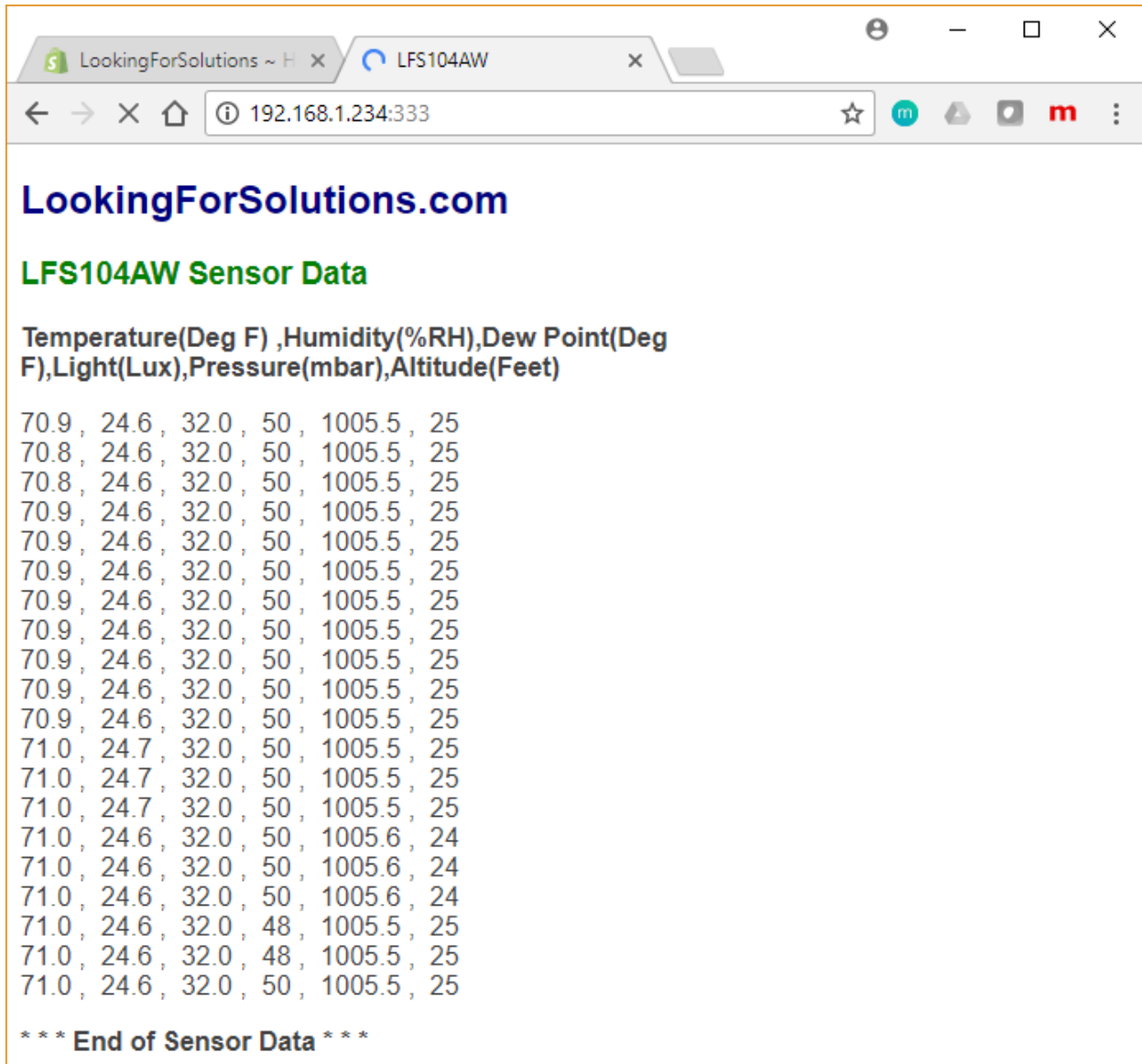

Figure 9 – Typical Sensor data from a web browser

2.5 – Send Data to the Cloud – IoT (Thingspeak.com), Direct

The board can send ambient temperature, relative humidity, dew point temperature, ambient light, barometric pressure, and reference altitude directly to Thingspeak.com web site (Without using a PC software) for data storage and data visualization.

You need to create an account with Thingspeak.com. After login process, create a new Private Channel. Fill in the Channel settings such as Name, Description, Field 1 (Ambient Temperature), Field 2 (Relative Humidity), Field 3 (Dew Point Temperature), Field 4 (Ambient Light), Field 5 (Barometric Pressure), and Field 6 (Reference Altitude). Go to API keys tab and look for “Write API Key”. Copy the API key code.

Go back to the read/configure WiFi module window menu (Figure 7). Check off the “Send Data to the Cloud - IoT” checkbox and enter (Paste) the API key in the text box. Select the Data sample rate. Click “Update WiFi Configuration” button. You will see a windows popup “WiFi Module updated!” to confirm. You can now send data directly to the cloud without any PC software intermediary.

Thingspeak.com provides many features such as data visualization and export, MATLAB analysis and Tweet alerts. Figures 10 & 11 show typical Thingspeak.com screens.

ThingSpeak™ Channels Apps Community Support How to Buy Account Sign Out

Private View Public View Channel Settings Sharing API Keys Data Import / Export

+ Add Visualizations Data Export

MATLAB Analysis MATLAB Visualization

Channel Stats

Created: 2 years ago
 Updated: 6 minutes ago
 Last entry: 6 minutes ago
 Entries: 7

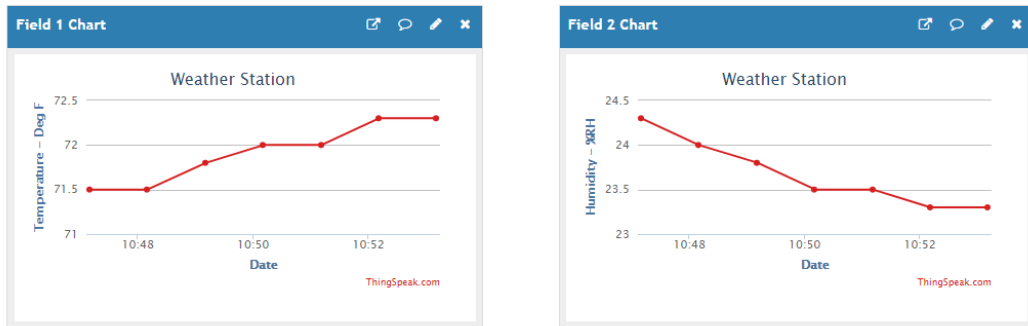

Figure 10 – Typical Thingspeak.com screen

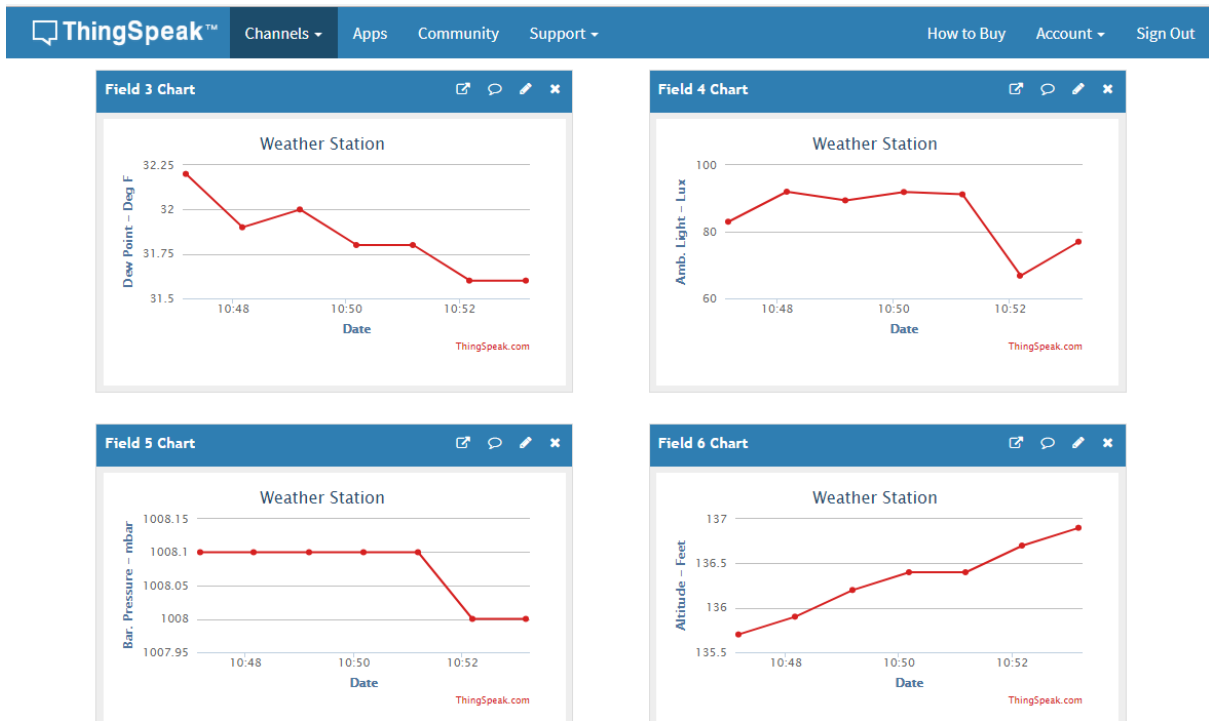

Figure 11 – Typical Thingspeak.com screen

2.6- Email Data/ Picture on alarm condition

If you select this Checkbox, the PC software application can send an email every time the temperature, relative humidity, ambient light, or barometric pressure goes into alarm condition. Check “Email Data/ Picture on alarm” checkbox and fill in the following items:

- Sender’s email address and password.
- Sender’s smtp mail server. Either select from the drop down list menu, or type in your specific mail server if it is not in the list.
- Port number and the SSL. It is already set for gmail & yahoo accounts.
- Message title and the Recipient’s email address.

You can send a test email to make sure it is functional. Click OK-Save button to save settings and exit.

2.7- Sending Text Message on alarm condition from PC

The PC software can send a text message to a cell phone every time the temperature, relative humidity, ambient light, or barometric pressure goes into alarm condition. Check “Send a Text message on alarm” checkbox and fill in the following additional items:

- Recipient’s Cellular Carrier
- Recipient’s cell phone number.

You can send a test Text Message to make sure it is functional. Click OK-Save button to save settings and exit.

2.8- Send Data to the Cloud – IoT (Thingspeak.com) from PC

The PC software can send ambient temperature, relative humidity, dew point temperature, ambient light, barometric pressure, and reference altitude data to Thingspeak.com web site for data storage and data visualization.

You need to create an account with Thingspeak.com. After login process, create a new Private Channel. Fill in the Channel settings such as Name, Description, Field 1 (Ambient Temperature), Field 2 (Relative Humidity), Field 3 (Dew Point Temperature), Field 4 (Ambient

Light), Field 5 (Barometric Pressure), and Field 6 (Reference Altitude). Go to API keys tab and look for “Write API Key”. Copy the API key code.

Go back to the settings menu software. Check off the “Send Data to the Cloud – IoT from PC” checkbox and enter (Paste) the API key in the text box. Click OK and go back to the main menu. Make sure the Chart speed selection is at least 30 seconds or longer before starting the session. Thingspeak.com provides many features such as data visualization and export, MATLAB analysis and Tweet alerts. Figures 10 & 11 show typical Thingspeak.com screens.

2.9- Verbalize on Alarm conditions

The PC software can announce a message when the temperature, relative humidity, ambient light, or barometric pressure goes into an alarm condition. Check “Verbalize on Alarm conditions” checkbox and click on the Speech button will open a new window that shows the default alarm messages. You can either use the default messages or make your own messages. You can click Test Voice Message button to test the voice function. Figure 12 shows the Speech window screen.

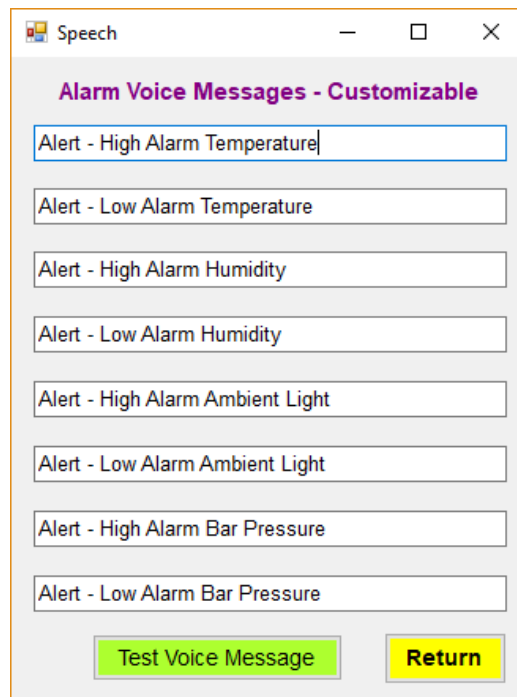

Figure 12 – Speech Screen

2.10- Take a Picture on Alarm conditions

You can take a picture of the event via the connected webcam when there is an alarm condition. When you start a monitoring session, you need to create a jpeg file and click on Live Video button to start the live video. Every time there is an alarm condition, the software takes a picture of the event and saves it under the jpeg file name. There could be multiple alarm conditions in a session, so multiple jpeg files will be created to save pictures. If “Email Data/Picture on alarm condition” checkbox is checked, the picture and the corresponding data will be emailed when an alarm condition occurs.

2.11- Configure Board Alarm outputs (USB or WiFi Connection)

You can read and change the board alarm output set points. From the settings menu click on “Board Alarm output Configuration” button. You can set two alarm outputs. Alarm 1 can be set as Temperature or Ambient Light (High or Low). Alarm 2 can be set as Humidity or Barometric Pressure (High or Low). Figure 13 shows a typical board alarm output screen. Figure 14 shows the wiring connections for the two alarm outputs.

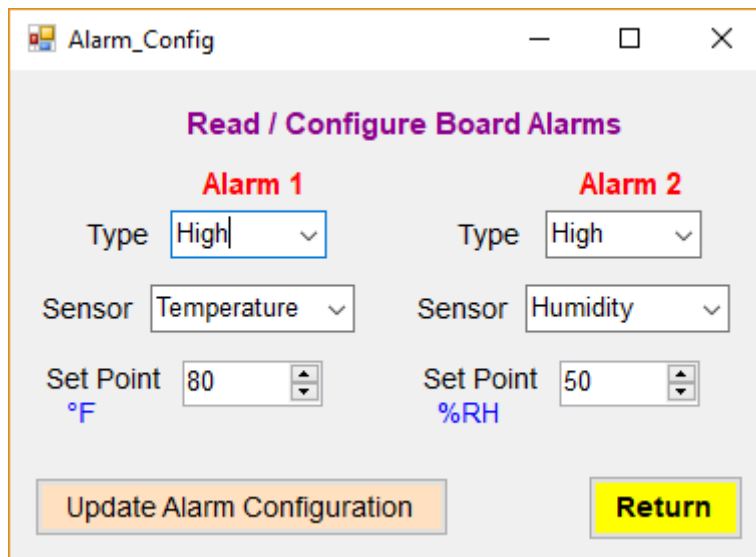

Figure 13 – Board Alarm output screen

3- Saving Data to the Storage Cloud

You can save the temperature, relative humidity, dew point, ambient light, barometric pressure, and reference altitude data to any storage cloud service such as Google Drive, One Drive, Dropbox, etc. as follows:

- Install the storage cloud service app on your PC as well as your smart phone or Tablet.
- Run our PC application, and Start the data monitoring/logging session.
- Create a data file under the cloud storage folder (Google Drive, One Drive, etc.), name the data file, and click Save.

Your data file is now created in the cloud storage folder. After closing the data file, you can review the data from your smart phone or tablet.

4- Specifications

Temperature

Range	-15 to 85 °C (5 to 185 °F)
Accuracy	1.4°C (2.5 °F)
Resolution	0.1 Degree

Relative Humidity

Range	0 to 100 %RH
Accuracy	3 %RH
Resolution	0.1 %RH

Ambient Light

Range	0 to 110,000 Lux
Accuracy	5% of Reading
Resolution	1 Lux

Barometric Pressure

Range	300 to 1100 mbar
Accuracy	2 mbar @ 25 °C

Resolution	0.1 mbar
PC Sampling Time	1 sec, 5 sec, 10 sec, 30 sec, 1 minute
PC Recording Interval	1 sec, 5 sec, 10 sec, 30 sec, 1 minute
Recorded value	Average value of incoming sample data at 1 sample/sec
Initial Warm up Period	2 minutes
Alarm output	0V (Low) , 3V (High) , 10 mA Drive
PC Software	Windows 10
Maximum data file	20,000 sets of data per file
Review Past Data on PC	200,000 sets of data
PC Software Serial Comm.	19,200 BPS, 8 bit, 1 Stop bit, No Parity
Power	USB 2.0
Webcam	Logitech C270 or Equivalent
Export Classification	
LFS104A	EAR99
LFS104AW	5A992c

Wireless Option (LFS104AW)

Wireless	WiFi 802.11 b/g/n
Frequency	2412 to 2452 MHz
Protocols	TCP/IP, UDP/IP, DHCP, HTTP, Telnet, FTP
WiFi Modes	Station / SoftAp (Access Point) / SoftAP+Station
Security	WPA, WPA2
Encryption	WEP / TKIP / AES
Connecting Channels	Up to 5
Serial Mode Communication	115,200 BPS, 8 bit, 1 Stop bit, No Parity
Power Transmit	
802.11 b	17 dBm, 170mA
802.11 g	15 dBm, 140 mA
802.11 n	13 dBm, 120 mA
Power Receive	
802.11 b	-80 dBm, 50mA
802.11 g	-70 dBm, 56 mA

802.11 n	-65 dBm, 56 mA
Data Sample rate to Cloud	30 sec, 1 minute, 10 minutes
IoT Cloud Platform	Thingspeak.com
Size of data saved to Cloud	
30 sec sample rate	3 Million set of data (2.8 Years)
1 minute sample rate	3 Million set of data (5.7 Years)
10 minutes sample rate	3 Million set of data (57 Years)
Dimensions	2.80 x 0.80 inches (71.1 x 20.3mm)

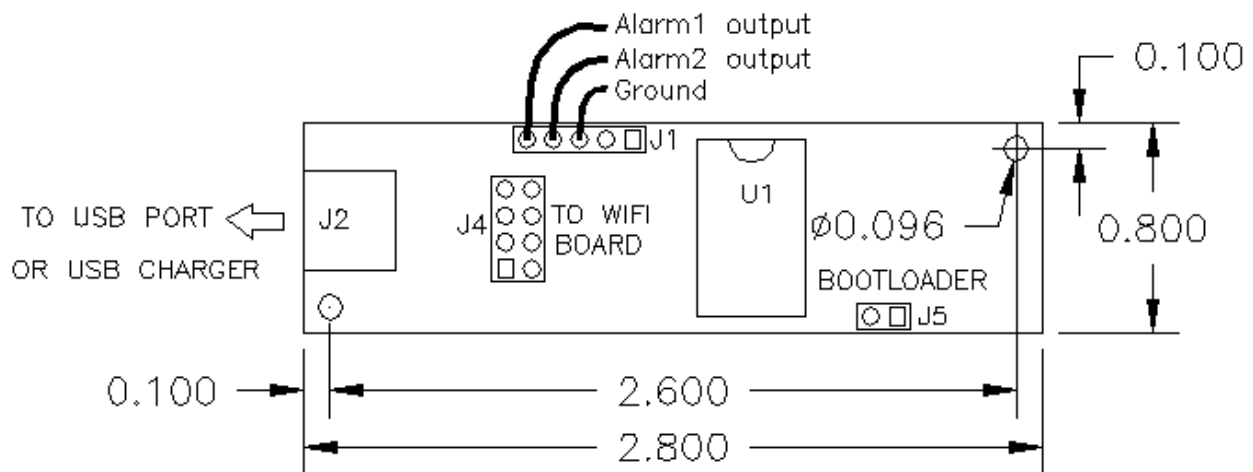

Figure 14 - General Dimensions, LFS104A

5- PC Commands

The following is a list of PC commands used to communicate with the board (CR means Carriage Return):

GETID<CR> - Read the Board ID (Model number)

GETSN<CR> - Read the Board Serial Number yywwxxx

GET1<CR> - Read the Ambient Temperature from the board. It provides the temperature in degree F times 10. For example if the temperature is 72.5 °F, it will send 725.

GET2<CR> - Read the Relative Humidity from the board. It provides the humidity in %RH times 10. For example if the humidity is 42.5%RH, it will send 425.

GET7<CR> - Read the Dew Point temperature from the board. It provides the dew point in degree F times 10. For example if the dew point is 36.7 °F, it will send 367.

GET9<CR> - Read the Ambient Light from the board. It provides the ambient light in Lux. For example if the ambient light is 356 Lux, it will send 356.

GET4<CR> - Read the Barometric Pressure from the board. It provides the barometric pressure in mbar times 10. For example if the barometric pressure is 1005.8 mbar, it will send 10058.

GETA1<CR> - Read the Reference Altitude from the board. It provides the reference altitude in feet. For example if the reference altitude is 125 feet, it will send 125.

6- Troubleshooting

Here is a list of items you need to be aware of if you get into problems:

- During the software installation, the Windows operating system may indicate “Unknown Publisher” or un-trustworthy source, please ignore and install the software. Our software has a Digital Signature and comes from a trusted source.
- Make sure the PC does not go to sleep mode, otherwise you will lose USB communication to the board.
- Make sure the PC sound is enabled to be able to use the verbalization (Speech) feature.
- Make sure your PC is connected to the internet if you are planning to use features like sending emails, text messages, or data to the cloud.
- Check your antivirus program for any blocking of the application to the internet.
- Check your wireless router for any blocking of the application to the internet.

Yahoo and Gmail accounts have additional security features that does not allow a third party app (Like our app) access the account. In order to access the account from our app, additional steps need to be taken as follows:

Yahoo Accounts:

You need to login to your Yahoo account and under Account Security add our app (LFS104A) and generate a Password. Then use that Password in our app for the account Password in the settings menu. Leave Port number as 25.

Gmail Accounts:

Sign into your Google account. Under Security, there is a section called “Less secure app access”. You need to turn this ON. This allows you to access your Gmail account from our app. Leave Port number as 25.

7- Third Party Software & Devices

You can interface and communicate with our products from single computer boards such as [Raspberry Pi](#). We provide sample Python program for your evaluation.

You can interface and communicate with our products from [National Instruments Labview](#) software platform. We provide sample program for your evaluation. Figure 15 shows a typical Labview screen.

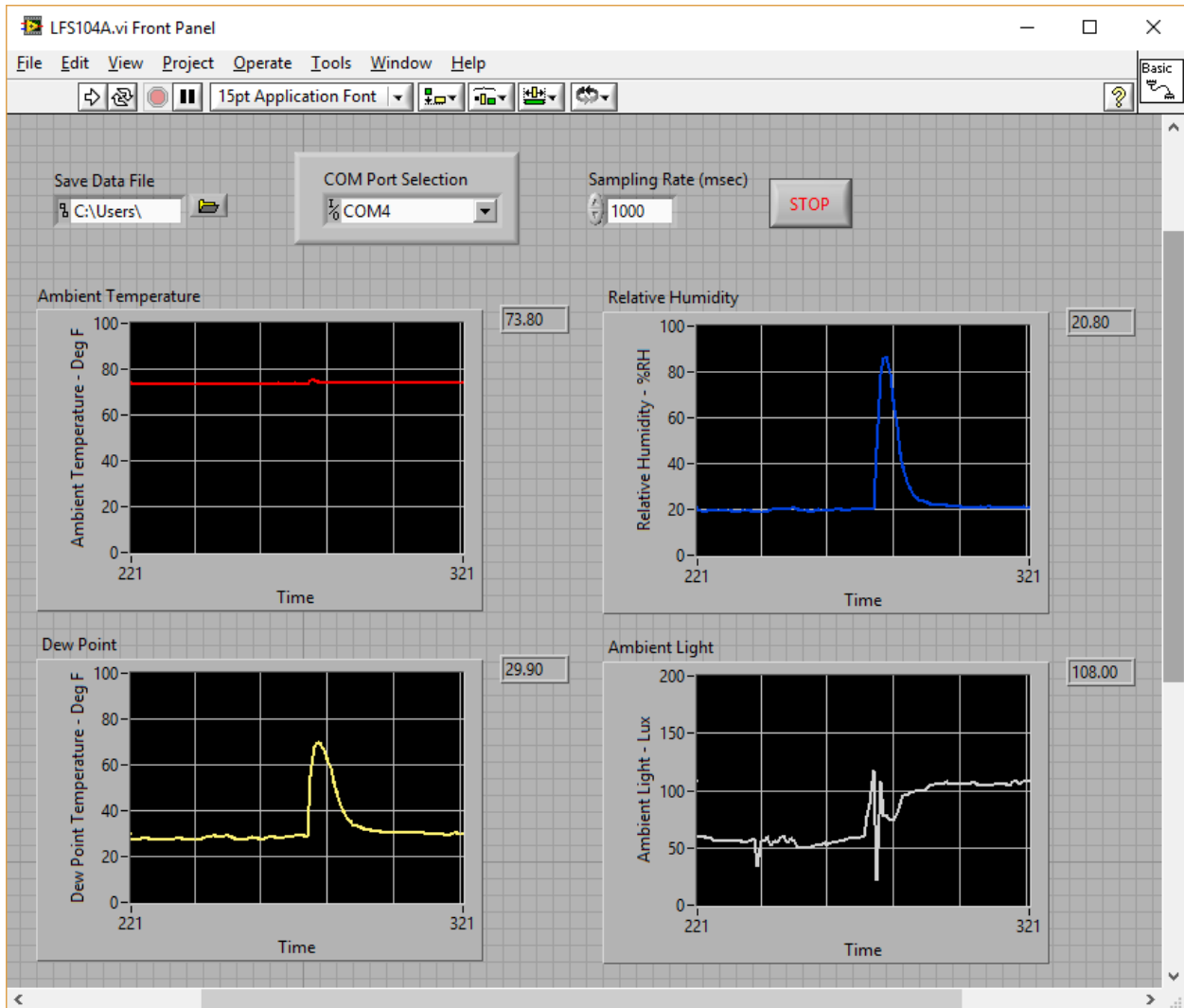

Figure 15 – Typical Labview screen