



SmartBright Highbay G2

BY228Z RL-M EN

SmartBright Highbay G2 is a high efficient and reliable LED luminaire. Designed as the point to point replacement for HPI 250W/400W luminaires, it offers customers all the benefits of LED lighting – reduced energy consumption, longer service time and less maintenance. In addition, with using high quality of the optical plate, it provides an excellent quality of light, which effectively improves the comfort of your environment.

Product data

General Information	
CE mark	-
Material	Aluminum
Accessory color	Gray

Mechanical and Housing	
Overall height	288 mm
Overall diameter	432 mm
Dimensions (Height x Width x Depth)	288 x NaN x NaN mm (11.3 x NaN x NaN in)

Product Data	
Full product code	911401822297
Order product name	BY228Z RL-M EN
Order code	911401822297
Numerator - Quantity Per Pack	1
Numerator - Packs per outer box	6
Material Nr. (12NC)	911401822297
Net Weight (Piece)	0.466 kg

SmartBright Highbay G2

Dimensional drawing

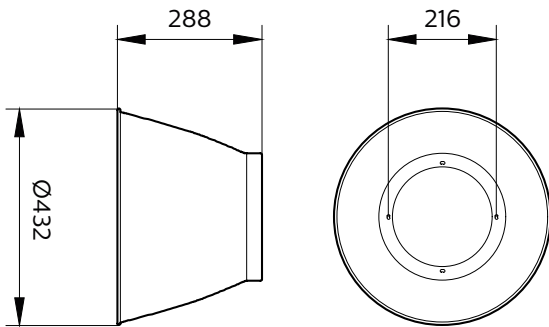

BY228Z/BY238Z SmartBright Highbay

